

CC 38.650-1

715 US TON CAPACITY



May 2022. Unless otherwise specified, all information in this brochure refers to a standard crane equipment, and it is intended as general information only. No liability is assumed. Errors reserved. Product specifications and prices are subject to changes without notice. The photographs and/or drawings in this brochure are for illustrative purposes only. For correct and safe crane operation, the original operating manual and lifting capacity charts are essential. Failure to follow the corresponding Operator's Manual when using our equipment or failure to otherwise act responsibly may result in property damage, serious injury or death. The sole warranty applicable with respect to our equipment is the standard warranty as per general terms and conditions of sales and service (ask your local Tadano dealer for details), and Tadano makes no other warranty, express or implied. All rights reserved. Any use of the trademarks, logos, brand names and model names used herein is prohibited.

© Tadano Ltd. 2022

Contents

Specifications		7
Working speeds.....		8
Hook block system		9
Hook block		9
Number of lines		9
Basic crane dimensions.....		10-11
Superlift configurations.....		12-13
Transportation		14-15
Boom heads.....		15
Erection / lowering of the boom systems to the ground		16-17
Boom combinations		18-21
Boom combinations – Boom Booster.....		22-25
Main boom		27
SH, LH		28-34
SSL, LSL		36-54
Fixed fly jib		55
SH+LF, LH+LF.....		56-71
SSL+LF		72-84
LSL+LF		85-127
Luffing fly jib		129
SW		130-149
SWSL, SFSL		150-190
Fixed fly jib (Vessellift)		191
LVSL		192-196
<hr/>		
Notes to Lifting Capacity.....		198
Technical description.....		200-201

Key



Track



Counterweight + central ballast (ZB)



Superlift counterweight



Central ballast



Superlift radius



Possible load of hook block



Weight of hook block



Load radius



Main boom



Fly jib



Mast



Main boom angle



Fly jib angle



Runner



Track shoe width



Hook block



Hoist 1



Hoist 2



Hoist 3



Jib luffing



Boom derricking



Boom hoist



Travel speed



Working speeds



Slewing



Max. line pull



Rope diameter



Rope length



Number of lines



Number of sheaves



Wind speed in ft/s (feet per second)

Key



Distance head sheave axle – hook ground

S: heavy

L: light

H, HA: Main boom

HI: Luffing jib

MA: Mast

R: Runner

W: Luffing fly jib

F: Fixed fly jib

SL: Superlift

V: Vessellift

SFSL: Variation of SWSL: all radii will be reached by adjusting the main boom angle (luffing fly jib 15° offset to main boom permanently)

Highlights

715 USt at 39.4 ft radius

Load moment of 66.196 ft-kips

Fall protection as standard

Erection of main boom 374.0 ft with 39.4 ft LF and hook block mounted:
without superlift mast and without assist crane

Erection of wind turbines up to **557.8 ft** hub height with superlift, up to 361 ft hub height without superlift











Best in class ergonomics for operator

Suitable for worldwide operation

SPECIFICATIONS









Specifications







Working speeds (infinitely variable)				
				
	max. 426.5 ft/min	40,500 lbf	1.1"	3281 ft
	max. 426.5 ft/min	40,500 lbf	1.1"	3281 ft
	max. 383.9 ft/min	40,500 lbf	1.1"	2133 ft
	max. 426.5 ft/min		1.1"	
	max. 410.1 ft/min		1.1"	
	max. 393.7 ft/min		1.1"	
	0-1 rpm			
	max. 0.68 mph			

1) top layer













Specifications

Hook block system					
					
2 x 325	1433,000 lb 838,000 lb	4 x 5 1 x 10	2 x 20 1 x 21	22,270 lb – 29,110 lb 16,100 lb – 24,920 lb (8,380 lb – 24,260 lb*)	18.4 ft 18.4 ft (16.1 ft*)
2 x 190	838,000 lb	2 x 5	2 x 11	16,100 lb – 24,920 lb (8,380 lb – 24,260 lb*)	19.4 ft (16.1 ft*)
	419,000 lb	1 x 5	1 x 11	13,670 lb (5,950 lb – 10,580 lb*)	19.4 ft (17.1 ft*)

* with optional equipment 882,000 lb or 441,000 lb hook

Hook block					
					
2 x 90	392,500 lb	2 x 2	2 x 5	5,070 lb – 19,620 lb	14.8 ft
1 x 125	272,300 lb	1 x 3	1 x 7	4,000 lb – 11,250 lb	15.1 ft
1 x 54	119,000 lb	1 x 1	1 x 3	2,430 lb – 7,280 lb	14.8 ft
1 x 18*	39,700 lb	–	1 x 1	2,430 lb	12.8 ft

* Single line hook

Number of lines																					
	1	2	3	4	5	6	7	8	9	10	11	12	13	14	15	16	17	18	19	20	21
	39,700 lb	79,400 lb	119,100 lb	156,600 lb	196,300 lb	233,700 lb	271,200 lb	308,700 lb	346,200 lb	381,400 lb	419,000 lb	454,200 lb	489,500 lb	524,800 lb	560,000 lb	595,400 lb	628,400 lb	661,500 lb	696,800 lb	729,900 lb	762,900 lb
 1 x 39,700 lb	X																				
 1 x 119,000 lb	X	X	X																		
 1 x 275,600 lb	X	X	X	X	X	X	X														
 1 x 419,000 lb				X	X	X	X	X	X	X	X										
 1 x 838,000 lb				X	X		X	X	X		X	X	X	X	X	X	X	X	X	X	X
	2 x 1	2 x 2	2 x 3	2 x 4	2 x 5	2 x 6	2 x 7	2 x 8	2 x 9	2 x 10	2 x 11	2 x 12	2 x 13	2 x 14	2 x 15	2 x 16	2 x 17	2 x 18	2 x 19	2 x 20	2 x 21
		158,800 lb	238,200 lb	313,200 lb	392,600 lb	467,400 lb	542,400 lb	617,400 lb	692,400 lb	762,800 lb	838,000 lb	908,400 lb	979,000 lb	1049,600 lb	1120,000 lb	1190,800 lb	1256,800 lb	1323,000 lb	1393,600 lb	1433,000 lb	1433,000 lb
 2 x 198,400 lb		X	X	X	X																
 2 x 419,000 lb			X	X	X	X	X	X	X	X	X										
 2 x 716,600 lb											X	X	X	X	X	X	X	X	X	X	X

Specifications

Basic crane dimensions

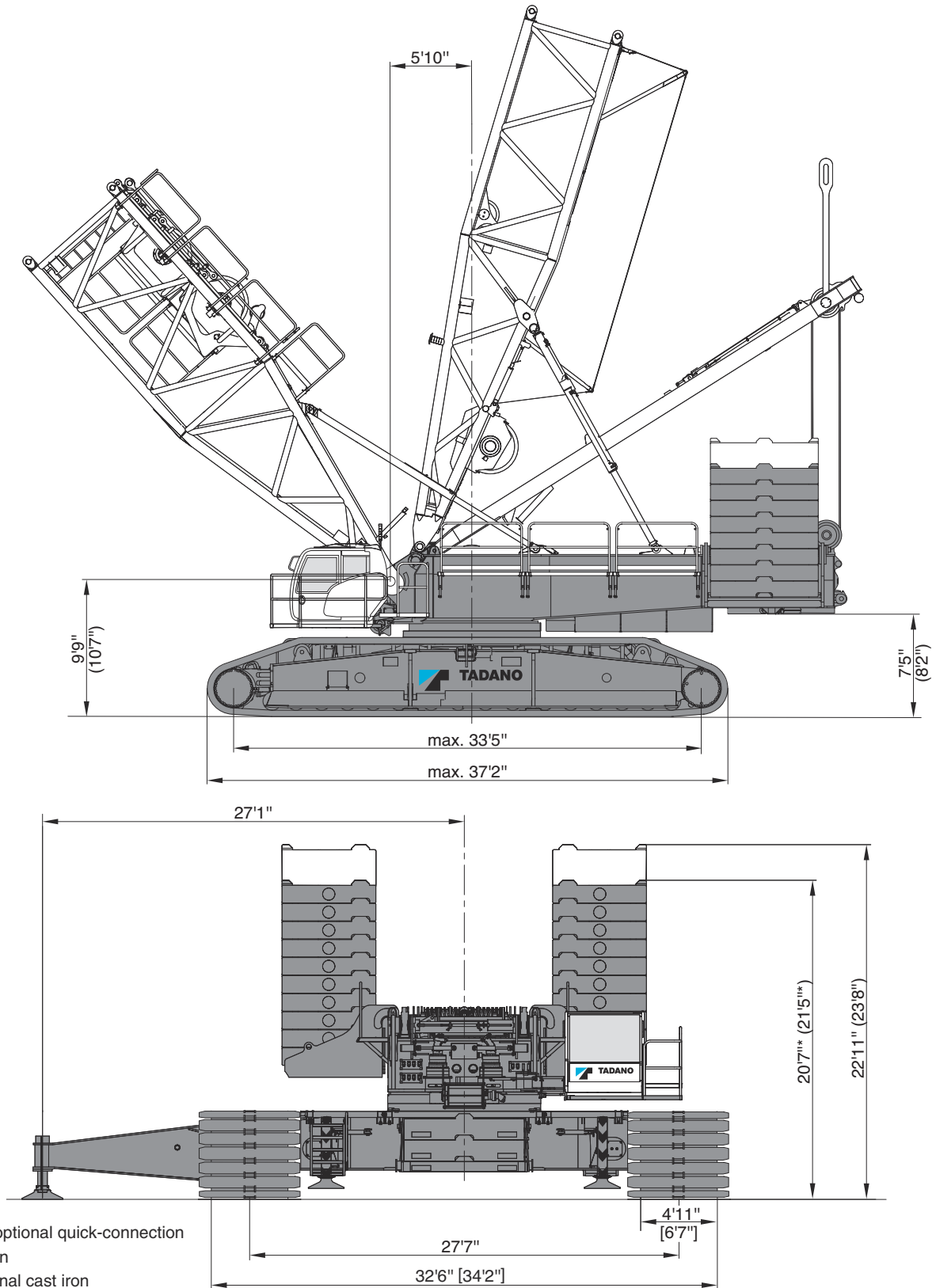

Specifications

Basic crane dimensions

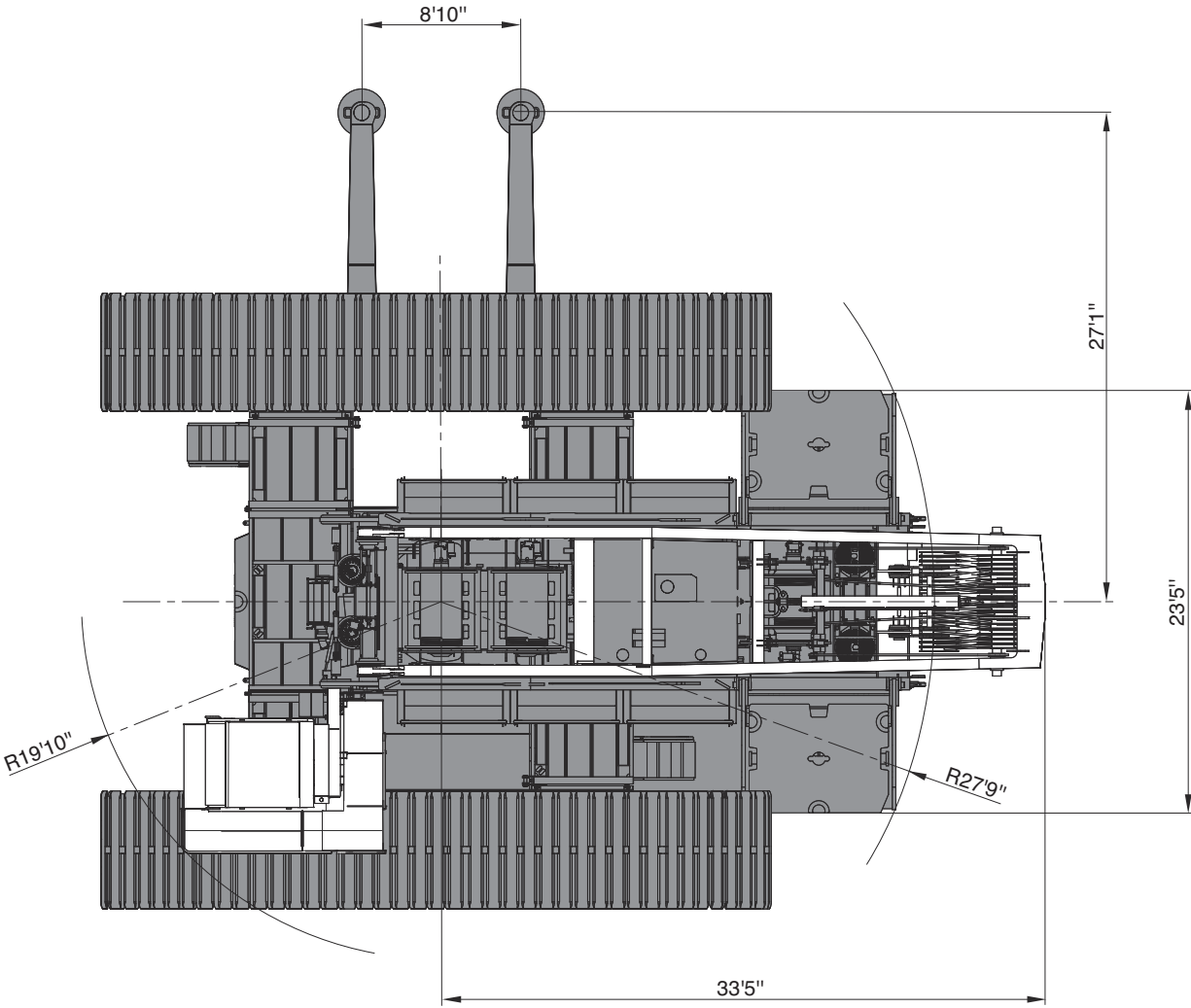

Specifications

Superlift configurations

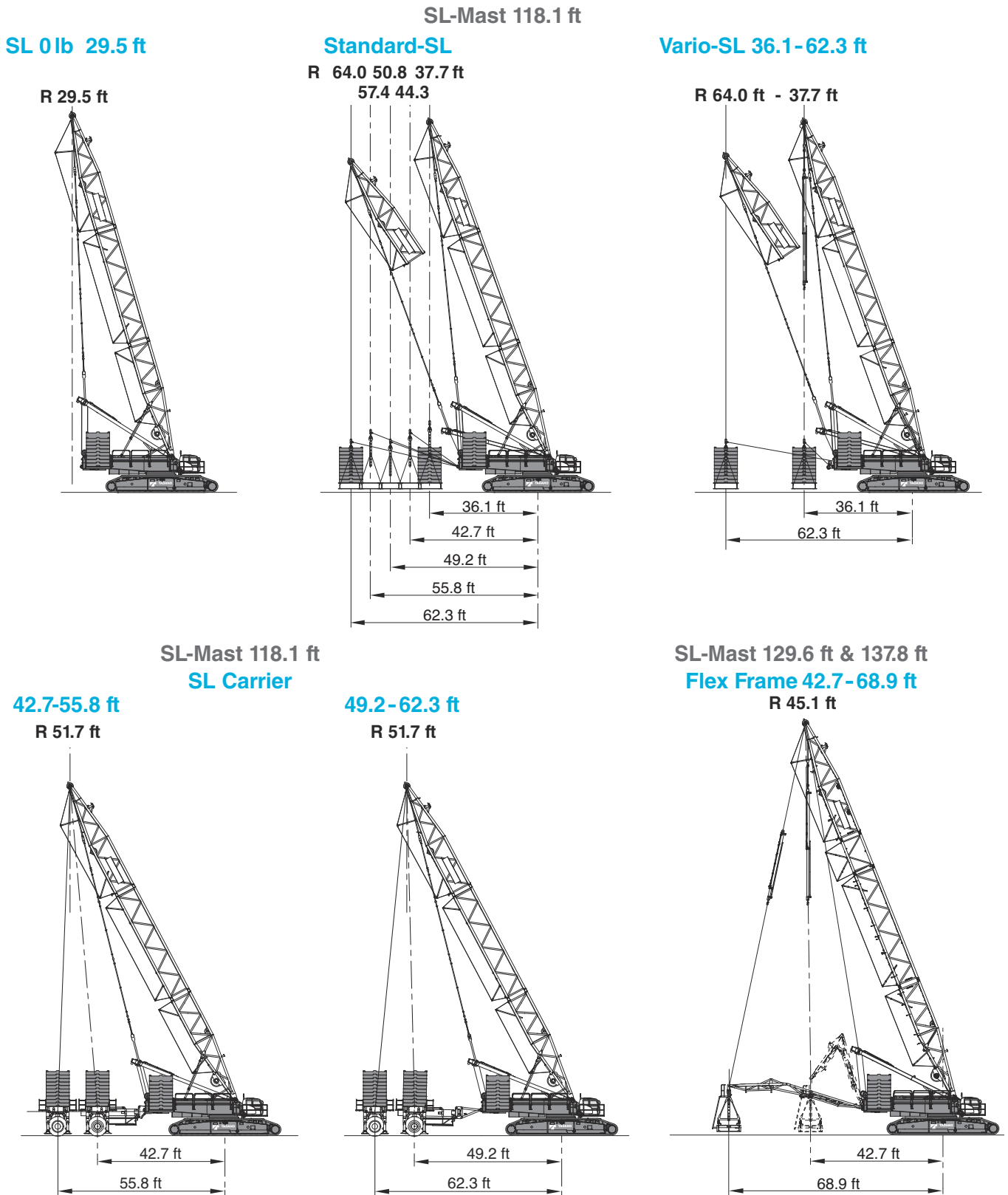

Specifications

Superlift configurations

SL-Mast 129.6 ft

Vario-SL 36.1-68.9 ft

SL Carrier

R 70.5 - 37.7 ft

R 45.1 ft

R 58.2 ft

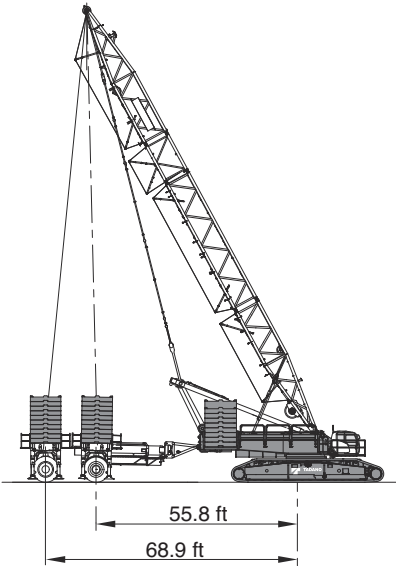
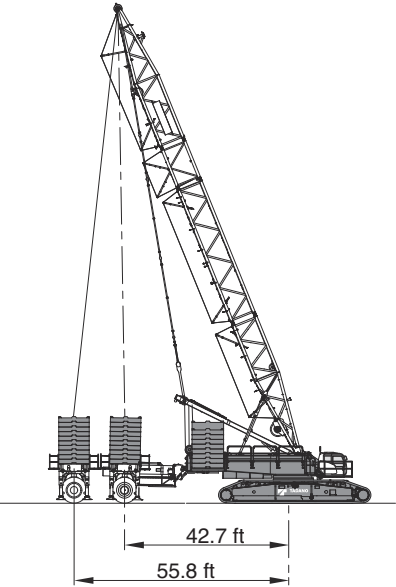
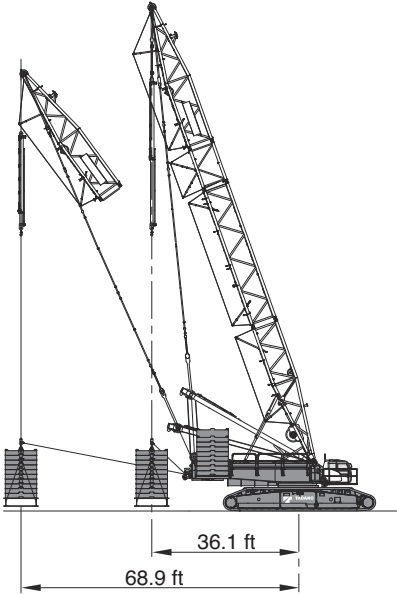

Alternatively, the telescope connector may be used in combination with the Superlift Tray

Specifications

Transportation

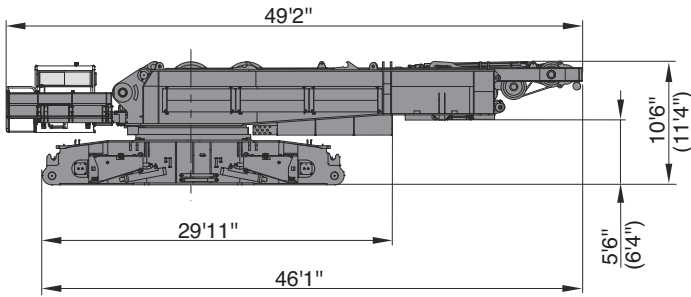

176,400 lb

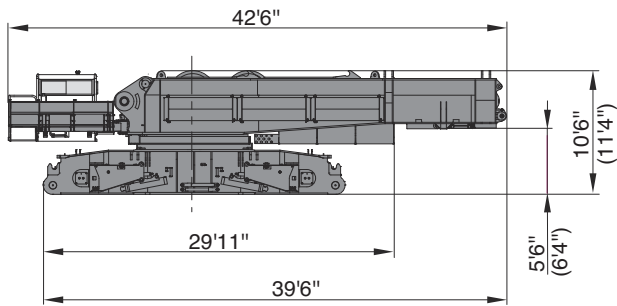

141,600 lb

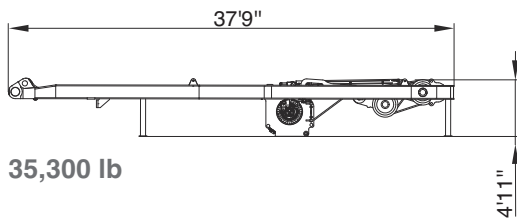

35,300 lb

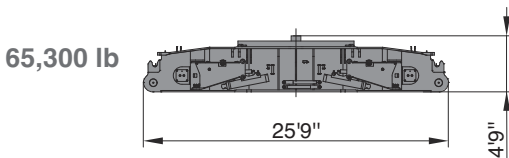

65,300 lb

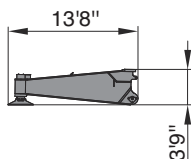

3,970 lb

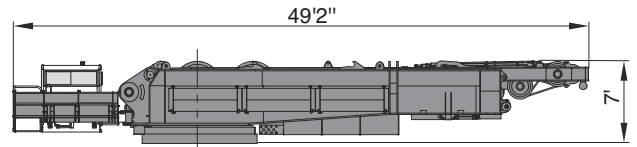

122,200 lb

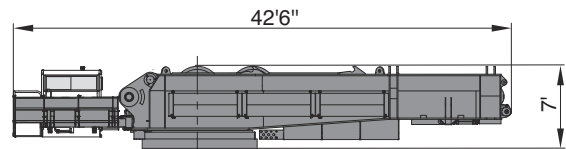

87,300 lb

Without winches H1 + H2 (15,430 lb each)

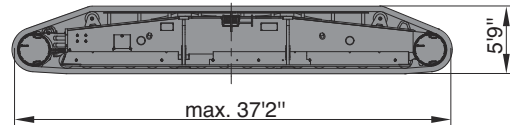

	Duo	Quadro
4.9 ft	82,250 lb	89,700 lb
6.6 ft	86,000 lb	93,500 lb

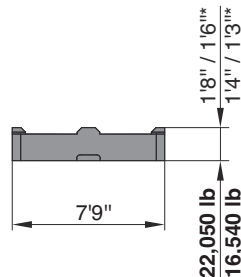

22,050 lb
16,540 lb

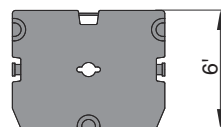

* Optional cast iron

2 additional side jacks optional

in brackets: with quick-connection

Specifications

Transportation

Boom Booster

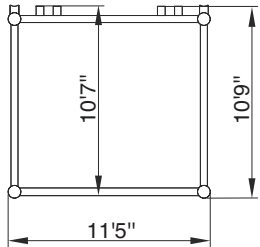

Type 3330A

Main Boom (HA)

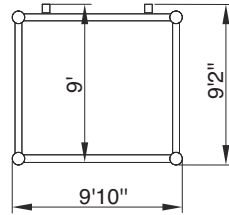

Type 2824A

Jib (HI) Superlift-Mast (MA)

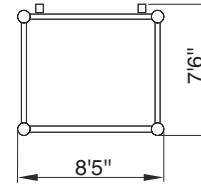

Type 2420A
Type M2420A (MA)

LF

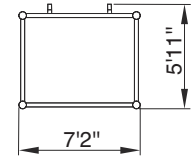

Type 2016A

Boom heads

A (max. 1433,000 lb)

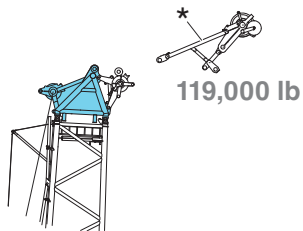

A1

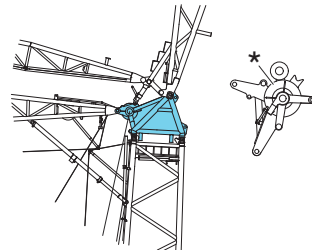

A2

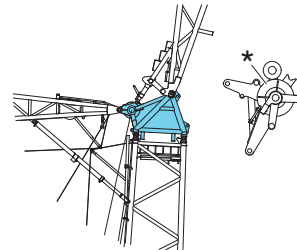

A3

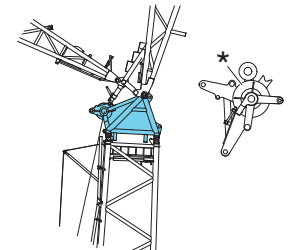

B (max. 772,000 lb)

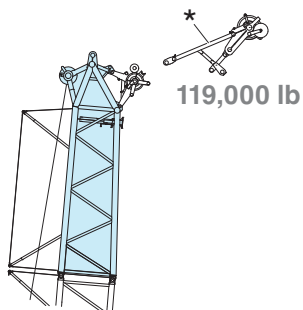

B1

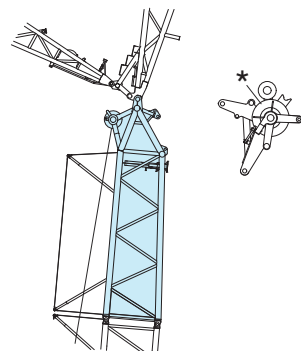

C





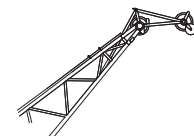

D (max. 392,500 lb)



* Attachable

Specifications











Erection / lowering of the boom systems to the ground																		
	ft	ft																
		78.7	98.4	118.1	137.8	157.5	177.2	196.9	216.5	236.2	255.9	275.6	295.3	315.0	334.6	354.3	374.0	
SH_1		X	X	X	X	X	X	X	X	X	[X]	[X]	[X]	[X]	-	-	-	
LH_1		-	-	X	X	X	X	X	X	X	X	X	[X]	[X]	[X]	[X]	[X]	
		118.1	128.0	137.8-246.1	255.9	265.8	275.6	285.5	295.3	305.1	315.0	324.8	334.6	344.5	354.3	364.2	374.0	
LH_5		X	X	X	[X]	[X]	[X]	[X]	[X]	[X]	[X]	[X]	[X]	[X]	[X]	[X]	[X]	
		78.7	98.4	118.1	137.8	157.5	177.2	196.9	216.5	236.2	255.9	275.6	295.3	315.0	334.6	354.3	374.0	
SW_1  85°	78.7-118.1	-	X	X	X	X	[X]	[X]	[X]	-	-	-	-	-	-	-	-	
	137.8-157.5	-	X	X	X	X	X	[X]	[X]	[X]	-	-	-	-	-	-	-	
	177.2-216.5	-	X	X	X	X	X	[X]	[X]	[X]	[X]	-	-	-	-	-	-	
	236.2-295.3	-	X	X	X	X	X	[X]	[X]	[X]	-	-	-	-	-	-	-	
	315.0	-	X	X	X	[X]	[X]	[X]	[X]	[X]	-	-	-	-	-	-	-	
SH+LF_1  15°, 20°, 30°	39.4	-	X	X	X	X	X	X	X	X	[X]	[X]	[X]	[X]	-	-	-	
	78.7	-	X	X	X	X	X	X	X	[X]	[X]	[X]	[X]	-	-	-	-	
	118.1	-	X	X	X	X	X	X	X	[X]	[X]	[X]	-	-	-	-	-	
LH+LF_1  15°, 20°, 30°	39.4	-	-	-	-	X	X	X	X	X	X	[X]	[X]	[X]	[X]	[X]	[X]	
	78.7	-	-	-	-	X	X	X	X	X	X	[X]	[X]	[X]	[X]	[X]	[X]	
	118.1	-	-	-	-	X	X	X	X	X	[X]	[X]	[X]	[X]	[X]	[X]	-	
					236.2	246.1	255.9	265.8	275.6	285.5	295.3	305.1	315.0	324.8	334.6	344.5	354.3	364.2
LH+LF_3  15°, 20°	39.4			X	X	X	X	X	[X]	[X]	[X]	[X]	[X]	[X]	[X]	[X]	[X]	
LH+LF_4  15°, 20°	39.4			-	-	-	-	[X]	[X]	[X]	[X]	[X]	[X]	[X]	[X]	[X]	-	
	59.0			-	-	-	-	[X]	[X]	[X]	[X]	[X]	[X]	[X]	-	-	-	

X without assisting equipment

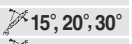
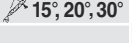
[X] with additional side jack

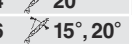
All Superlift combinations can be erected or lowered to the ground without assisting equipment.

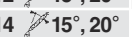
Specifications

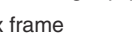
Erection / lowering of the boom systems to the ground																							
																							
	ft	ft	118.1	137.8	157.5	177.2	196.9	216.5	236.2	255.9	275.6	295.3	315.0	334.6	354.3	374.0	393.7	413.4	433.1	452.8	472.4	492.1	511.8
SSL_1	118.1		X	X	X	X	X	X	X	X	X	X	X	X	X	-	-	-	-	-	-	-	-
SSL_2	129.6		-	X	X	X	X	X	X	X	X	X	X	X	X	-	-	-	-	-	-	-	-
SSL_3	129.6		-	-	X	X	X	X	X	X	X	X	X	X	X	-	-	-	-	-	-	-	-
SSL_4	129.6		-	-	-	-	X	X	X	X	X	X	X	X	X	-	-	-	-	-	-	-	-
LSL_1	118.1		-	-	-	-	-	X	X	X	X	X	X	X	X	X	X	X	X	X	X	X	-
LSL_2	118.1		-	-	-	X	X	X	X	X	X	X	X	X	X	X	X	X	X	X	X	X	-
SWSL_1 	118.1	78.7	X	X	X	X	X	X	X	X	X	X	X	-	-	-	-	-	-	-	-	-	
		98.4	X	X	X	X	X	X	X	X	X	X	X	-	-	-	-	-	-	-	-	-	
		118.1 - 196.9	X	X	X	X	X	X	X	X	X	X	X	-	-	-	-	-	-	-	-	-	
		216.5 - 295.3	X	X	X	X	X	X	X	X	X	X	X	-	-	-	-	-	-	-	-	-	
		315.0	X	X	X	X	X	X	X	X	X	X	X	-	-	-	-	-	-	-	-	-	
SWSL_3 SWSL_4 	129.6	78.7	-	-	o	o	X	X	X	X	X	X	-	-	-	-	-	-	-	-	-	-	
		98.4	-	-	o	o	X	X	X	X	X	X	X	-	-	-	-	-	-	-	-	-	
		118.1 - 275.6	-	-	o	o	X	X	X	X	X	X	X	-	-	-	-	-	-	-	-	-	
		295.3	-	-	o	o	X	X	X	X	X	X	X	-	-	-	-	-	-	-	-	-	
		315.0	-	-	o	o	X	X	X	X	X	X	X	-	-	-	-	-	-	-	-	-	
SSL+LF_1 	118.1	39.4, 78.7, 118.1	-	X	X	X	X	X	X	X	X	X	X	X	-	-	-	-	-	-	-	-	
LSL+LF_2 	118.1	39.4, 78.7, 118.1	-	-	-	-	-	X	X	X	X	X	X	X	X	X	X	X	X	X	X	-	
LVSL_1	118.1	39.4	X	X	X	X	X	X	X	X	X	X	X	X	-	-	-	-	-	-	-	-	
LVSL_3, LVSL_4	129.6	39.4	-	-	o	o	X	X	X	X	X	X	X	X	-	-	-	-	-	-	-	-	
			255.9	275.6	295.3	305.1	315.0	324.8	334.6	344.5	354.3	364.2	374.0	383.9	393.7-403.5	413.4-423.2	433.1-482.3	492.1-521.7	531.5	541.3	551.2	561.0	
LSL_5	118.1		-	-	-	-	-	-	-	-	-	-	X	X	X	X	X	X	X	-	-	-	
LSL_7	118.1		-	-	-	-	X	X	X	X	X	X	X	X	X	X	X	X	X	-	-	-	
LSL_9	129.6		-	-	-	-	-	X	X	X	X	X	X	X	X	X	X	X	(X)	(X)	-	-	
LSL_11	129.6		-	-	-	-	-	X	X	X	X	X	X	X	X	X	X	X	(X)	(X)	-	-	
LSL_13	129.6		-	-	-	-	-	-	-	-	-	-	-	X	X	X	X	(X)	(X)	(X)	(X)	-	
LSL_15	137.8		X	X	X	X	X	X	X	X	X	X	X	X	X	X	X	(X)	(X)	(X)	(X)	(X)	(X)
LSL+LF_3 	118.1	39.4	X	X	X	-	X	-	X	-	X	X	X	X	X	X	X	-	-	-	-	-	
LSL+LF_4 	118.1	39.4	-	-	-	-	-	X	X	X	X	X	X	X	X	X	X	X	-	-	-	-	
LSL+LF_4 	118.1	78.7	-	-	-	-	-	X	X	X	X	X	X	X	X	X	X	X	-	-	-	-	
LSL+LF_6 	118.1	39.4	-	-	X	X	X	X	X	X	X	X	X	X	X	X	X	X	-	-	-	-	
LSL+LF_8 	129.6	39.4	-	-	-	-	X	X	X	X	X	X	X	X	X	X	X	X	-	-	-	-	
LSL+LF_10 	129.6	39.4	-	-	-	-	X	X	X	X	X	X	X	X	X	X	X	X	(X)	(X)	-	-	
LSL+LF_12 	129.6	39.4	-	-	-	-	-	-	-	-	-	-	X	X	X	X	X	(X)	(X)	-	-	-	
LSL+LF_14 	137.8	39.4, 59.0, 78.7	-	-	X	X	X	X	X	X	X	X	X	X	X	(X)	(X)	(X)	(X)	(X)	-	-	

X without assisting equipment

(X) with flex frame

o only SWSL_3/LVSL_3

The amount of Superlift counterweight required for erecting the boom system depends on the configuration and the Superlift radius.

Specifications

Boom combinations

Type 2824A

Type 2420A

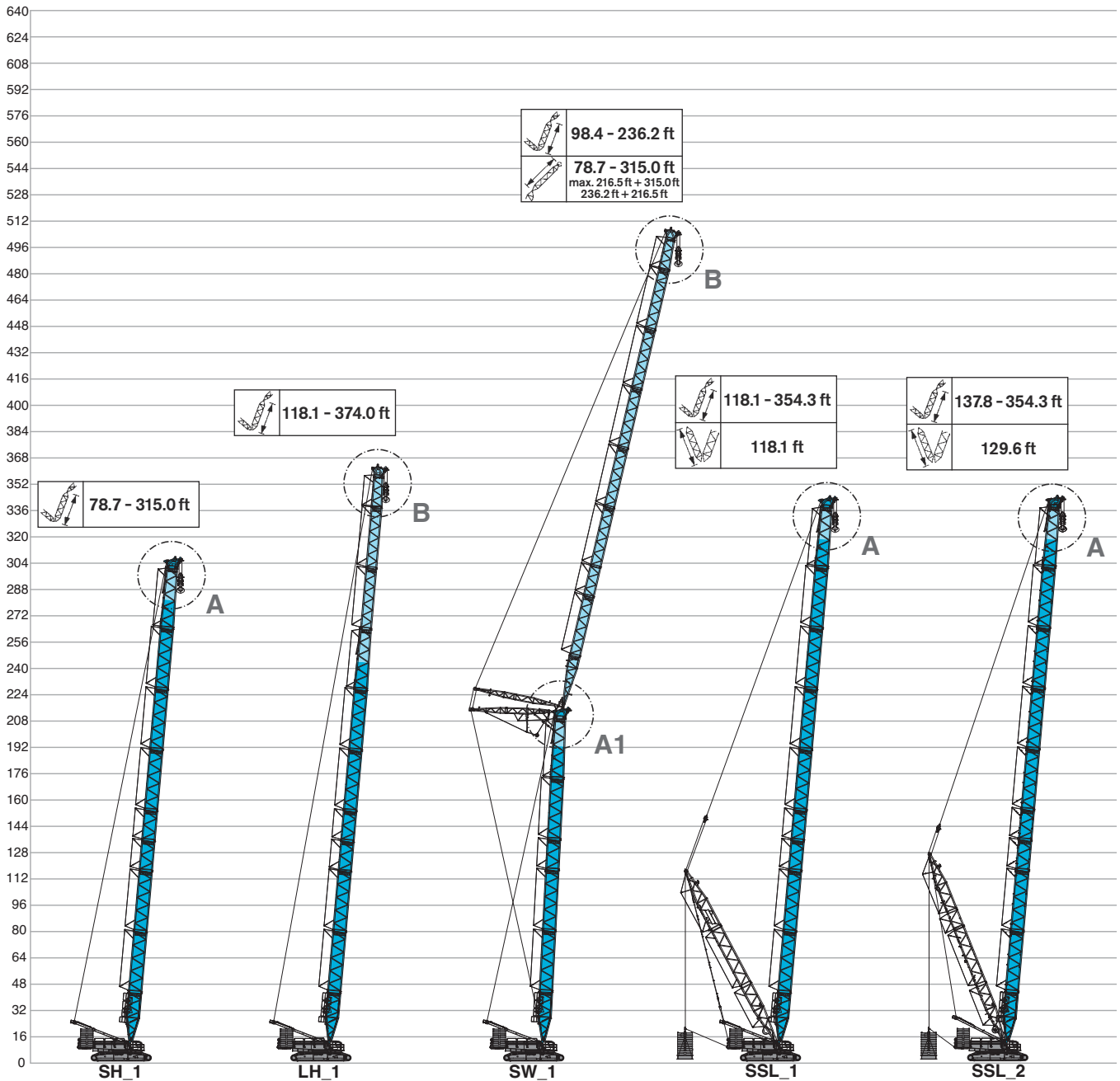

Specifications

Boom combinations

Type 2824A

Type 2420A

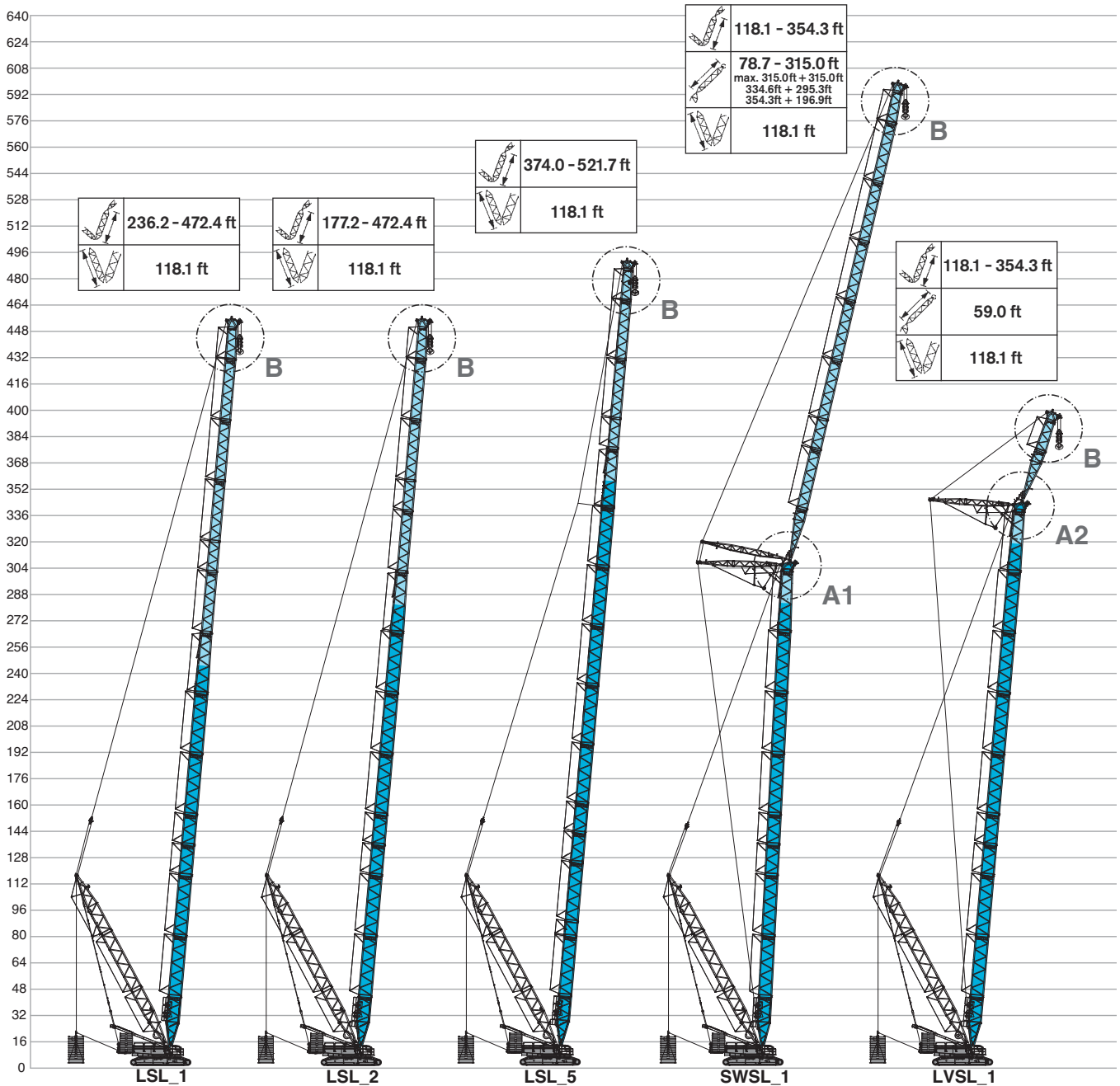

Specifications

Boom combinations

Type 2824A

Type 2420A

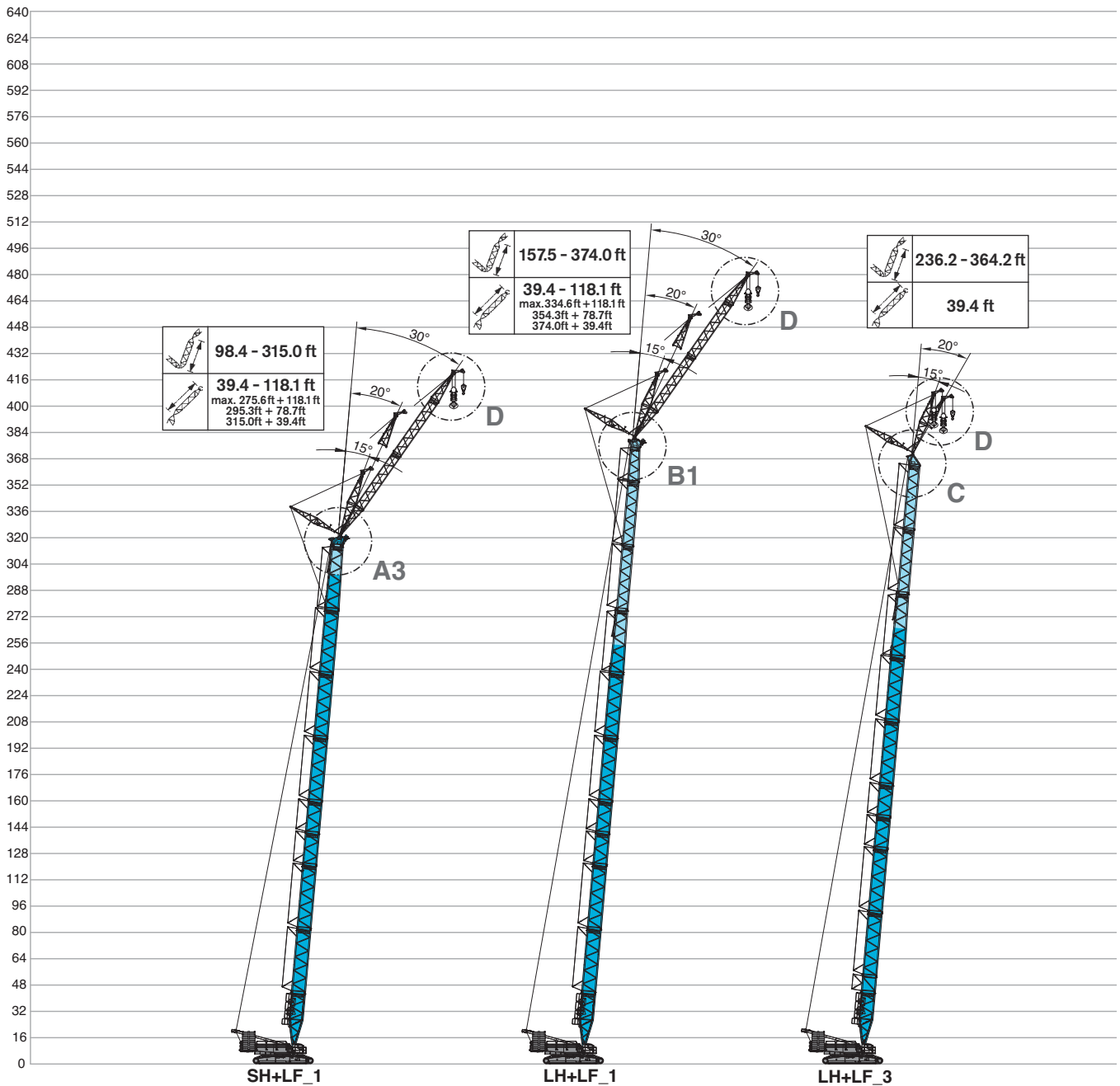

Specifications

Boom combinations

Type 2824A

Type 2420A

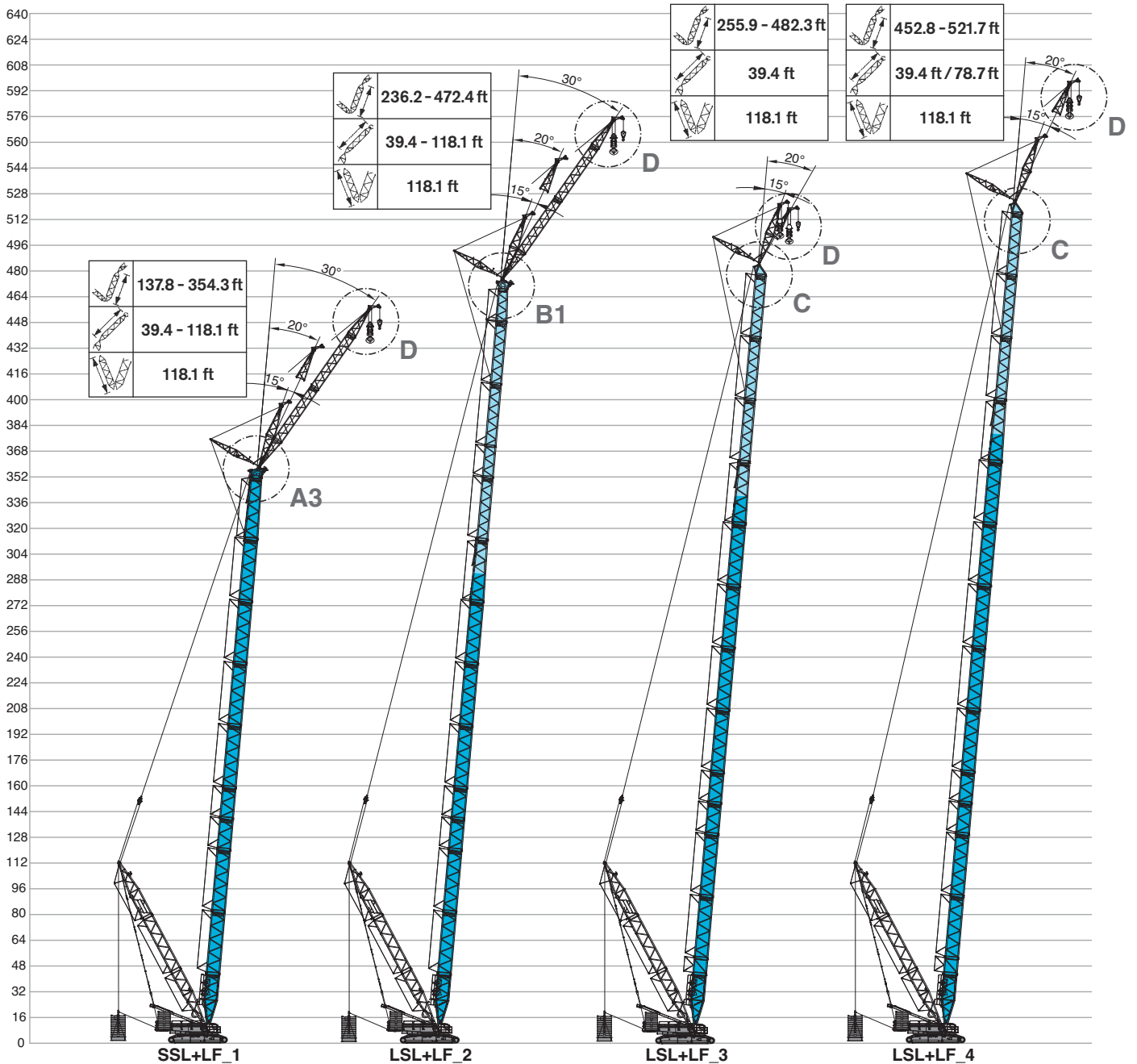

Boom combinations

Boom system type 3330A in combination with extended SL mast (129.6 ft or 137.8 ft); 2824A and 2420A with slide-in function.

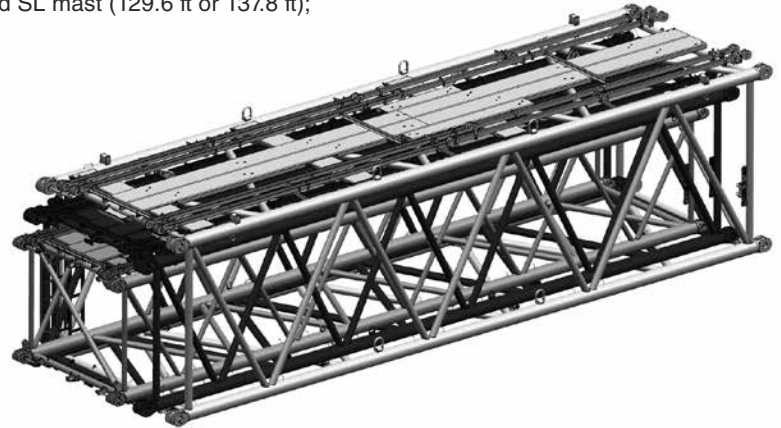

Type 3330A
 Type 2420A
 Type 2824A

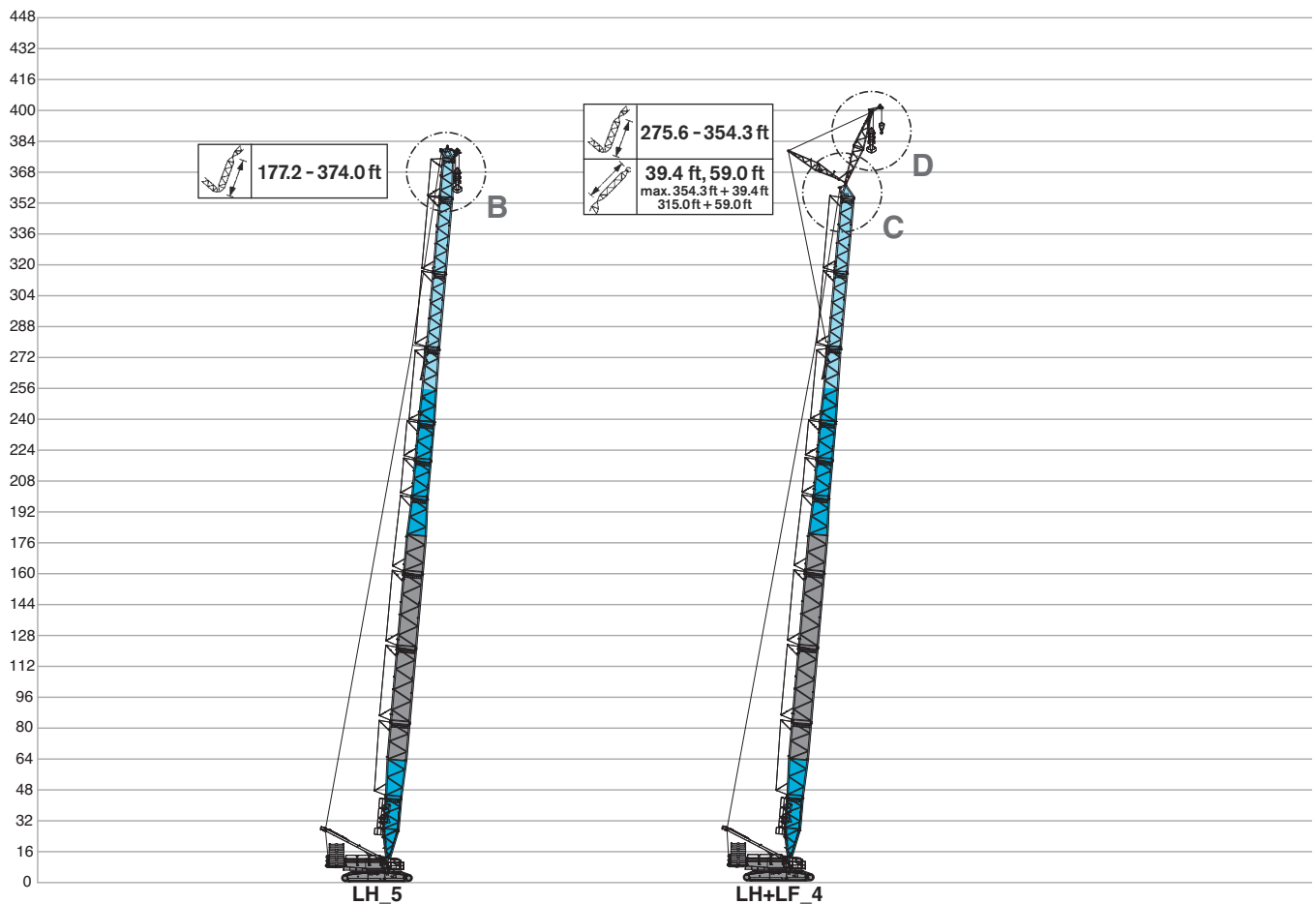

Boom combinations

Type 3330A
 Type 2420A
 Type 2824A

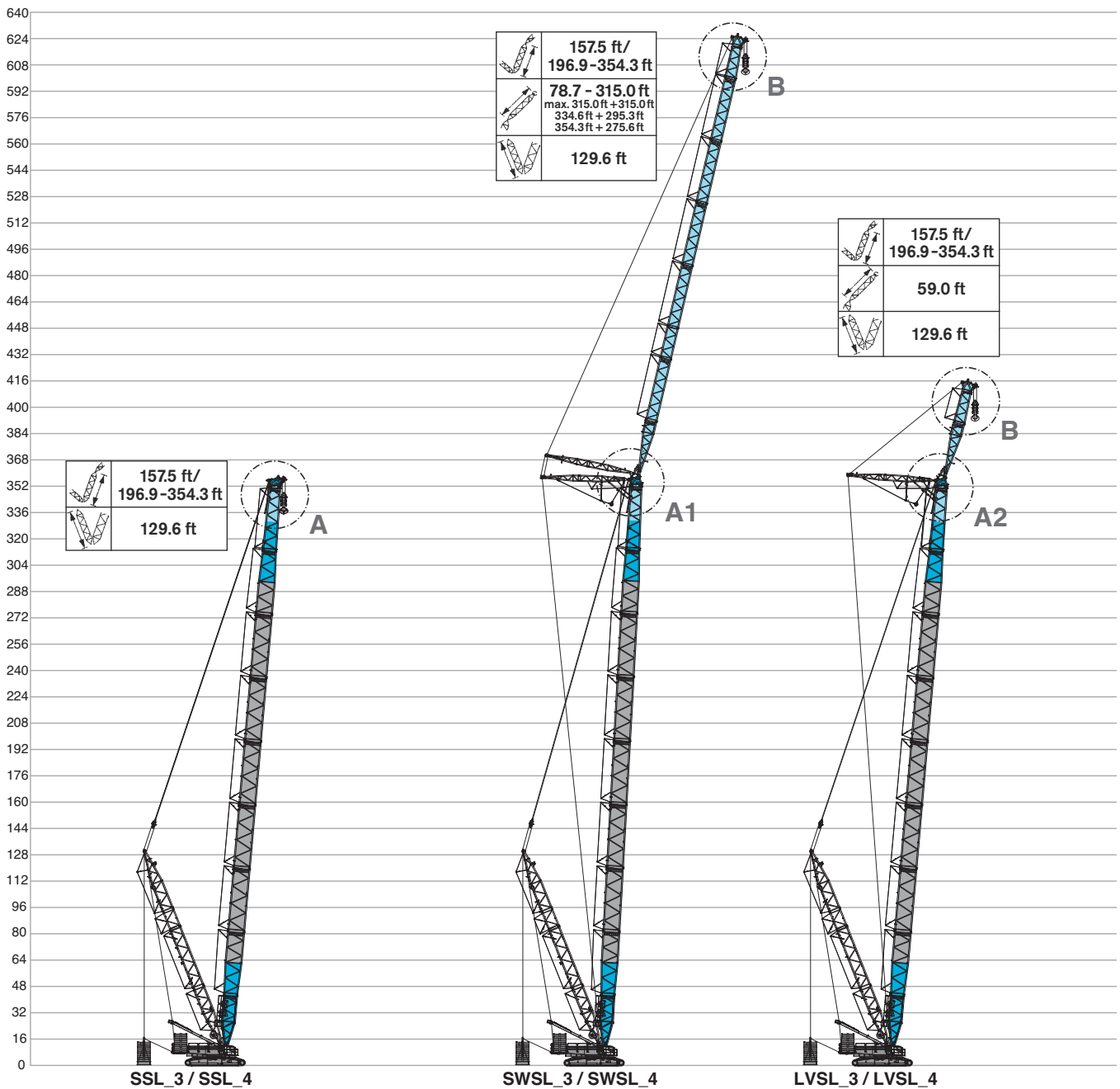

Boom combinations

Type 3330A
 Type 2420A
 Type 2824A

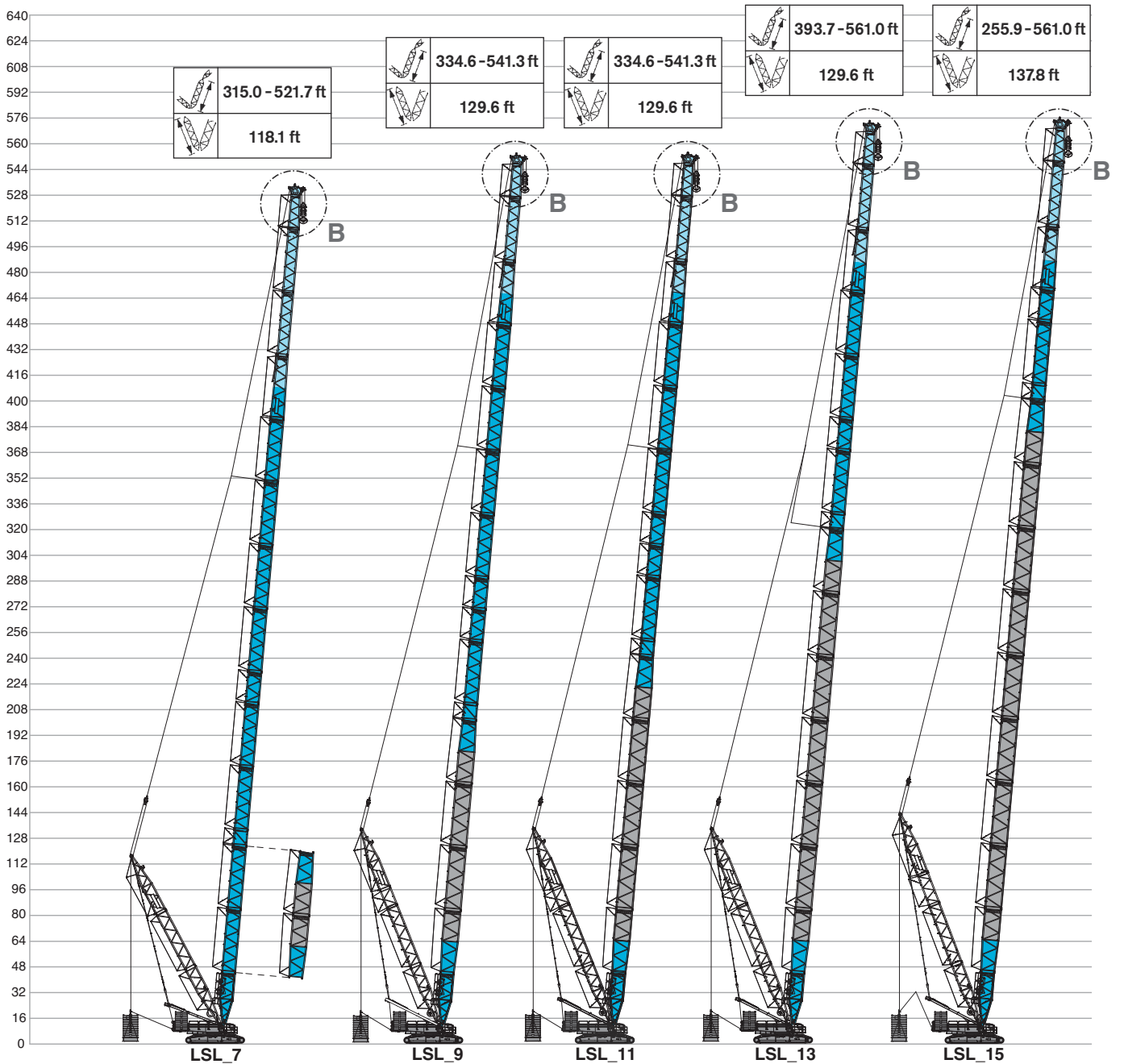

Specifications

BoomBooster

Boom combinations

Type 3330A
 Type 2420A
 Type 2824A

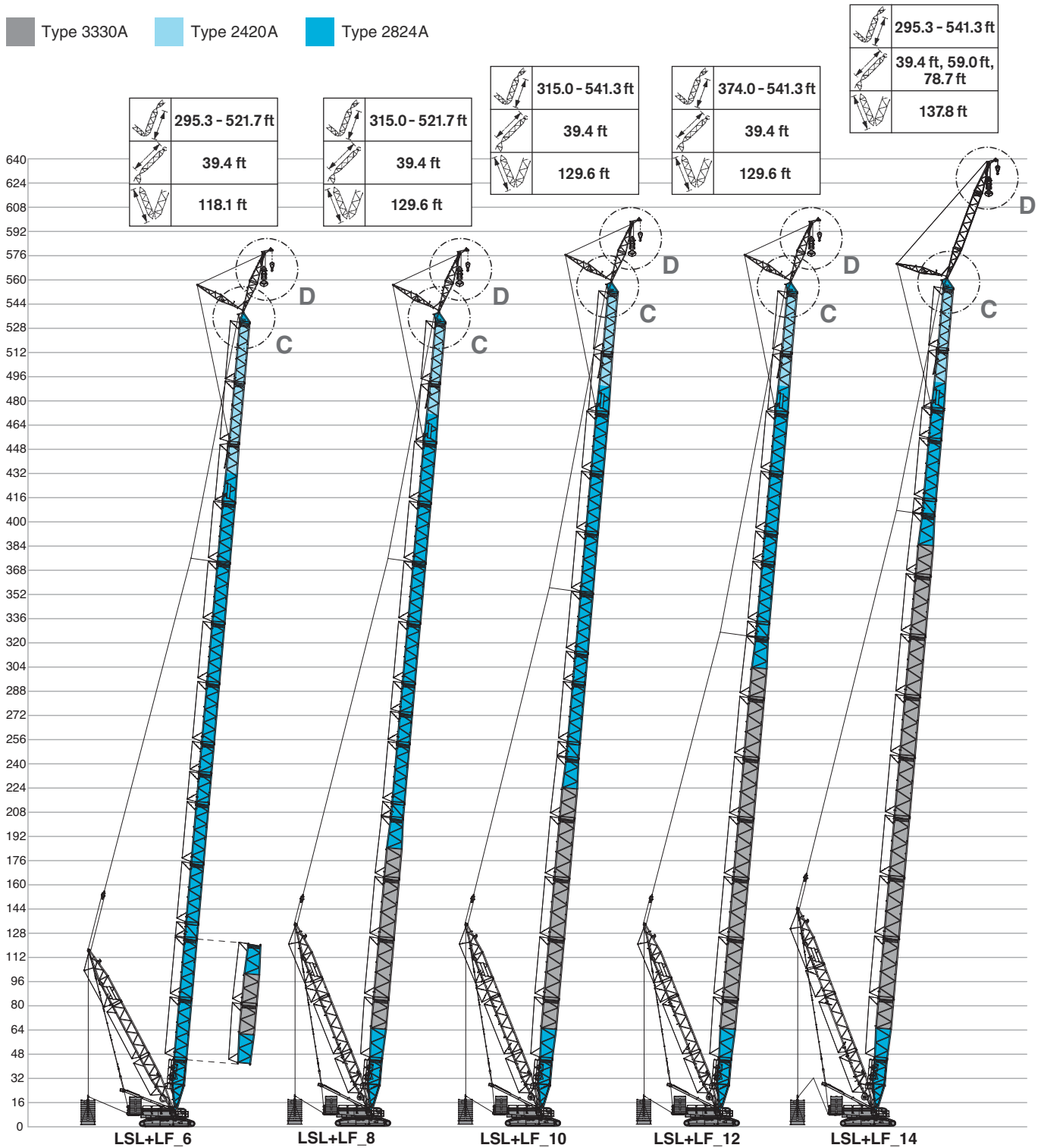

MAIN BOOM

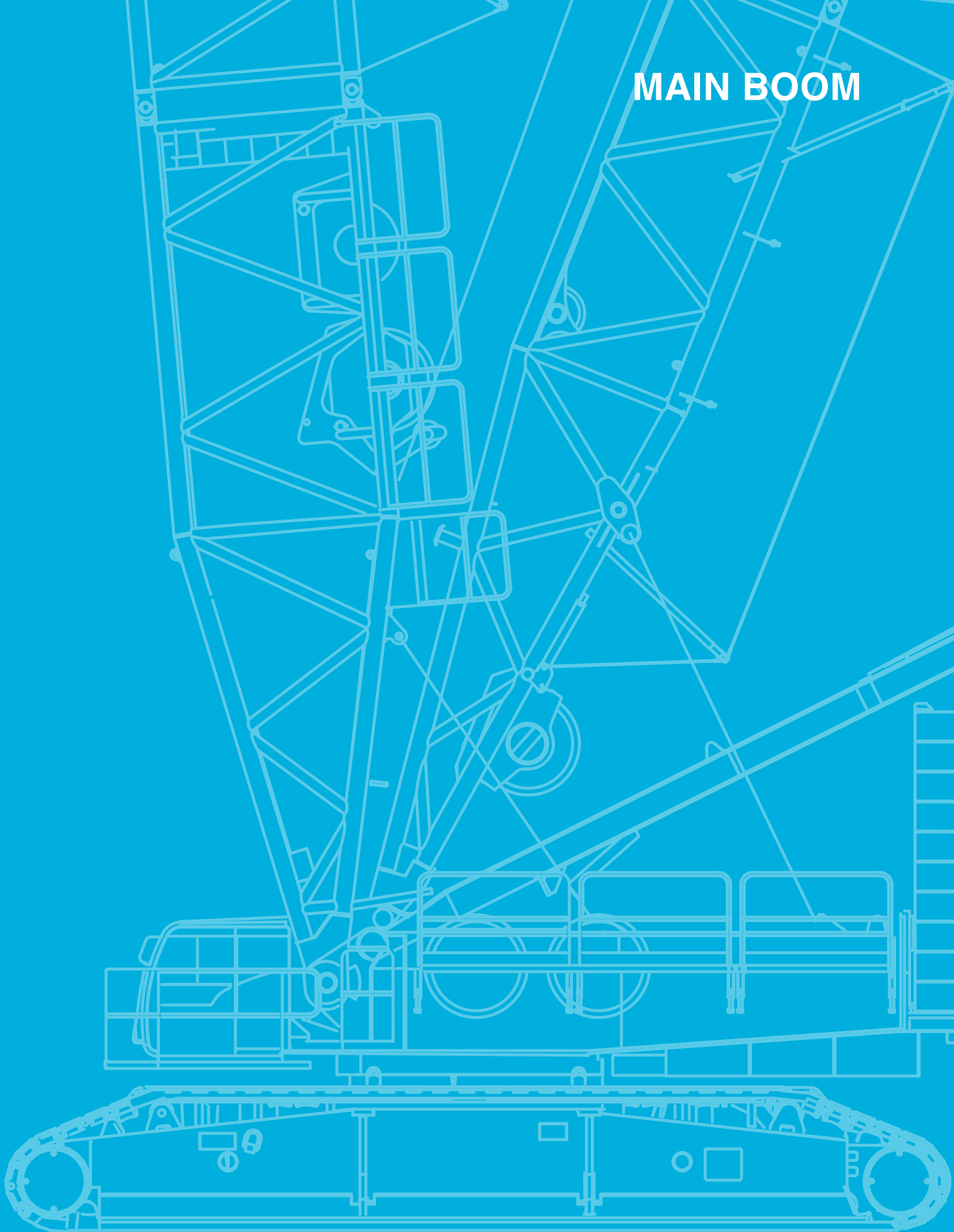

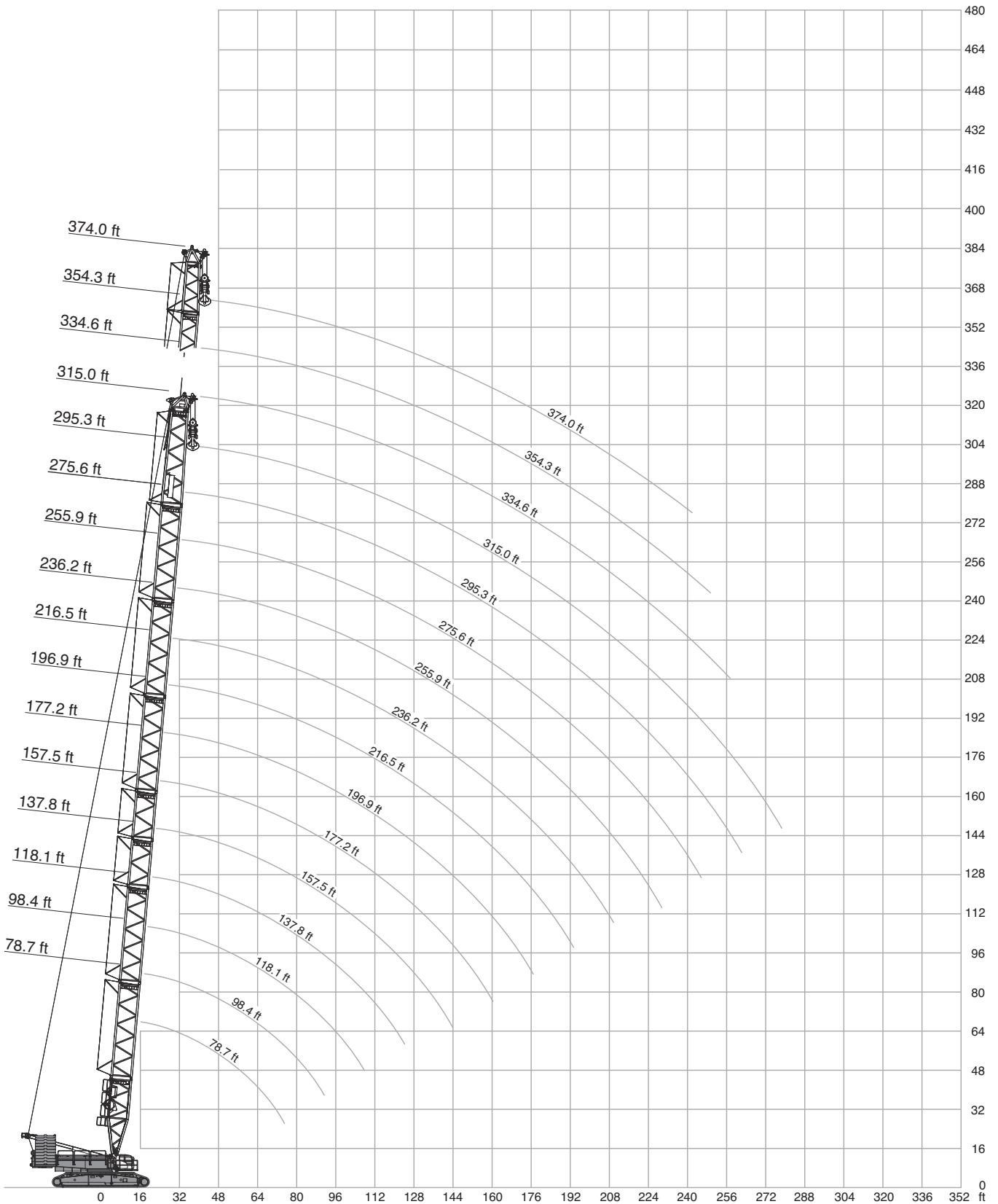



Operation

SH

		27.6 ft					32.2 ft/s					360°					ASME B30.5				
SH_1																					
ft		78.7	98.4	118.1	137.8	157.5	177.2	196.9	216.5	236.2	255.9	275.6	295.3	315.0	ft						
1,000 lb																					
18.0	1406.6	-	-	-	-	-	-	-	-	-	-	-	-	-	-	18.0					
19.7	1327.2	1320.6	-	-	-	-	-	-	-	-	-	-	-	-	-	19.7					
23.0	1190.5	1186.1	1179.5	1095.7	-	-	-	-	-	-	-	-	-	-	-	23.0					
26.2	1064.8	1060.4	1007.5	937.0	873.0	817.9	-	-	-	-	-	-	-	-	-	26.2					
29.5	941.4	934.8	870.8	815.7	765.0	720.9	679.0	-	-	-	-	-	-	-	-	29.5					
32.8	842.2	815.7	767.2	723.1	681.2	643.8	610.7	579.8	551.2	-	-	-	-	-	-	32.8					
36.1	744.1	729.7	691.1	653.7	618.4	586.4	556.7	530.2	504.9	480.6	456.4	-	-	-	-	36.1					
39.4	646.0	643.8	615.1	584.2	555.6	529.1	502.7	480.6	458.6	440.9	421.1	405.7	385.8	-	-	39.4					
45.9	502.7	502.7	500.4	489.4	467.4	445.3	425.5	410.1	390.2	377.0	359.4	348.3	332.9	-	-	45.9					
52.5	410.1	407.9	407.9	403.4	401.2	383.6	368.2	352.7	339.5	326.3	313.1	304.2	291.0	-	-	52.5					
59.1	346.1	343.9	341.7	337.3	337.3	335.1	321.9	310.9	297.6	286.6	275.6	266.8	255.7	-	-	59.1					
65.6	297.6	293.2	291.0	288.8	286.6	284.4	282.2	275.6	262.4	255.7	244.7	238.1	227.1	-	-	65.6					
72.2	260.1	255.7	253.5	251.3	249.1	246.9	244.7	242.5	233.7	227.1	218.3	212.7	202.8	-	-	72.2					
75.5	244.7	241.4	239.2	235.9	234.2	232.0	229.3	228.2	222.1	216.1	207.2	202.3	192.9	-	-	75.5					
78.7	-	227.1	224.9	220.5	219.4	217.2	213.8	213.8	210.5	205.0	196.2	191.8	183.0	-	-	78.7					
85.3	-	202.8	199.5	196.2	194.0	191.8	189.6	188.5	185.2	184.1	177.5	173.1	164.2	-	-	85.3					
91.9	-	183.0	179.7	176.4	174.2	170.9	168.7	167.6	165.3	164.2	160.9	156.5	148.8	-	-	91.9					
98.4	-	-	163.1	159.8	156.5	154.3	151.0	149.9	147.7	146.6	143.3	143.3	135.6	-	-	98.4					
108.3	-	-	142.2	139.2	135.9	133.7	130.3	129.2	125.7	124.6	122.4	122.4	118.2	-	-	108.3					
111.5	-	-	-	132.3	129.0	126.8	123.5	122.4	120.2	117.9	115.7	115.7	112.4	-	-	111.5					
124.7	-	-	-	112.4	109.3	106.3	103.4	102.1	99.0	97.4	94.1	93.5	90.6	-	-	124.7					
137.8	-	-	-	-	93.5	89.9	86.9	85.1	81.4	79.8	76.5	75.6	72.8	-	-	137.8					
144.4	-	-	-	-	86.9	83.4	79.7	77.6	74.3	72.6	69.3	68.5	65.5	-	-	144.4					
150.9	-	-	-	-	-	76.9	73.0	71.0	67.2	65.5	62.2	61.3	58.2	-	-	150.9					
160.8	-	-	-	-	-	68.6	64.5	62.4	58.5	56.7	53.1	52.4	49.4	-	-	160.8					
164.0	-	-	-	-	-	-	61.7	59.5	55.6	53.8	50.3	49.6	46.5	-	-	164.0					
177.2	-	-	-	-	-	-	52.5	50.0	46.1	44.1	40.6	39.7	36.6	-	-	177.2					
190.3	-	-	-	-	-	-	-	42.3	37.9	36.2	32.4	31.5	28.2	-	-	190.3					
193.6	-	-	-	-	-	-	-	40.6	36.2	34.4	30.6	29.8	26.4	-	-	193.6					
203.4	-	-	-	-	-	-	-	-	31.1	29.1	25.4	24.5	20.9	-	-	203.4					
210.0	-	-	-	-	-	-	-	-	28.2	26.2	22.3	21.4	17.9	-	-	210.0					
216.5	-	-	-	-	-	-	-	-	-	23.4	19.4	18.3	14.8	-	-	216.5					
223.1	-	-	-	-	-	-	-	-	-	20.9	16.8	15.7	12.1	-	-	223.1					
229.7	-	-	-	-	-	-	-	-	-	18.3	14.1	13.0	-	-	-	229.7					
232.9	-	-	-	-	-	-	-	-	-	-	13.0	11.9	-	-	-	232.9					
236.2	-	-	-	-	-	-	-	-	-	-	11.9	-	-	-	-	236.2					

 408,000 lb 452,000 lb
 66,100 lb 110,200 lb

27.6 ft 32.2 ft/s 360°															
SH_1															
ft	ft	78.7	98.4	118.1	137.8	157.5	177.2	196.9	216.5	236.2	255.9	275.6	295.3	315.0	ft
1,000 lb															
18.0	1382.3	-	-	-	-	-	-	-	-	-	-	-	-	-	18.0
19.7	1208.1	1280.9	-	-	-	-	-	-	-	-	-	-	-	-	19.7
23.0	1137.6	1034.0	945.8	866.4	-	-	-	-	-	-	-	-	-	-	23.0
26.2	939.2	862.0	798.1	740.8	687.8	643.8	-	-	-	-	-	-	-	-	26.2
29.5	795.9	738.5	687.8	643.8	604.1	566.6	533.5	-	-	-	-	-	-	-	29.5
32.8	687.8	643.8	604.1	568.8	535.7	504.9	476.2	451.9	427.7	-	-	-	-	-	32.8
36.1	597.5	575.4	543.4	513.7	485.0	458.6	434.3	412.3	391.3	370.4	352.7	-	-	-	36.1
39.4	507.1	507.1	482.8	458.6	434.3	412.3	392.4	372.6	354.9	339.5	324.1	310.9	295.4	-	39.4
45.9	394.6	392.4	392.4	381.4	363.8	346.1	328.5	315.3	299.8	288.8	275.6	264.6	251.3	-	45.9
52.5	319.7	319.7	317.5	315.3	310.9	295.4	282.2	271.2	257.9	249.1	235.9	229.3	218.3	-	52.5
59.1	269.0	266.8	264.6	260.1	260.1	257.9	244.7	235.9	224.9	217.2	207.2	200.6	190.7	-	59.1
65.6	229.3	227.1	224.9	222.7	220.5	218.3	216.1	208.3	197.3	190.7	181.9	176.4	167.6	-	65.6
72.2	200.6	197.3	195.1	191.8	189.6	187.4	185.2	184.1	175.3	169.8	160.9	156.5	147.7	-	72.2
75.5	188.5	185.7	183.0	179.7	177.5	175.3	173.1	172.0	165.9	160.4	152.1	147.7	139.4	-	75.5
78.7	-	174.2	170.9	167.6	165.3	163.1	160.9	159.8	156.5	151.0	143.3	138.9	131.2	-	78.7
85.3	-	154.3	151.0	147.7	145.5	143.3	141.1	140.0	136.7	135.6	127.9	124.6	116.8	-	85.3
91.9	-	138.9	135.6	132.3	130.1	126.8	124.6	123.5	120.2	119.0	114.6	111.3	104.5	-	91.9
98.4	-	-	122.4	117.9	115.7	113.5	110.2	109.8	106.9	105.8	103.0	100.3	93.5	-	98.4
108.3	-	-	106.0	102.6	99.9	97.0	94.2	92.9	89.1	87.7	84.9	84.0	79.6	-	108.3
111.5	-	-	-	97.4	94.6	91.5	88.8	87.3	83.8	82.2	79.1	78.5	75.0	-	111.5
124.7	-	-	-	81.4	78.0	74.3	71.0	69.4	65.7	64.2	61.1	60.4	57.3	-	124.7
137.8	-	-	-	-	64.6	60.8	57.1	55.3	51.6	50.0	46.7	46.1	43.0	-	137.8
144.4	-	-	-	-	59.3	55.4	51.4	49.4	46.0	44.3	41.0	40.3	37.3	-	144.4
150.9	-	-	-	-	-	50.0	46.1	44.1	40.3	38.6	35.3	34.6	31.5	-	150.9
160.8	-	-	-	-	-	43.4	39.5	37.3	33.4	31.6	28.0	27.3	24.3	-	160.8
164.0	-	-	-	-	-	-	37.3	35.1	31.1	29.3	25.8	25.1	22.0	-	164.0
177.2	-	-	-	-	-	-	30.0	27.6	23.4	21.6	18.1	17.2	14.1	-	177.2
180.4	-	-	-	-	-	-	-	26.0	21.8	20.0	16.4	15.5	12.3	-	180.4
187.0	-	-	-	-	-	-	-	22.9	18.7	16.8	13.1	12.1	-	-	187.0
190.3	-	-	-	-	-	-	-	21.4	17.2	15.2	11.5	-	-	-	190.3
193.6	-	-	-	-	-	-	-	20.1	15.8	13.8	-	-	-	-	193.6
200.1	-	-	-	-	-	-	-	-	13.1	11.0	-	-	-	-	200.1
203.4	-	-	-	-	-	-	-	-	-	11.7	-	-	-	-	203.4

275,600 lb
363,800 lb

Operation

LH

		27.6 ft					32.2 ft/s					360°					ASME B30.5				
		LH_1					LH_5					LH_1					LH_5				
ft		118.1	137.8	157.5	177.2	187.0	196.9	206.7	216.5	226.4	236.2	246.1	255.9	265.8	1,000 lb		ft				
23.0	765.0	765.0	-	-	-	-	-	-	-	-	-	-	-	-	-	-	-	23.0			
26.2	765.0	765.0	765.0	765.0	765.0	765.0	-	-	-	-	-	-	-	-	-	-	-	26.2			
29.5	765.0	765.0	765.0	734.1	765.0	765.0	692.3	765.0	762.8	654.8	743.0	723.1	-	-	-	-	-	29.5			
32.8	765.0	729.7	694.5	657.0	736.3	718.7	621.7	701.1	683.4	590.8	665.8	650.4	562.2	634.9	619.5	535.7	604.1	590.8	32.8		
39.4	623.9	590.8	568.8	542.3	601.9	588.6	515.9	575.4	562.2	493.8	551.2	537.9	471.8	526.9	513.7	451.9	502.7	491.6	39.4		
45.9	509.3	496.0	480.6	458.6	504.9	496.0	440.9	485.0	476.2	421.1	465.2	456.4	405.7	447.5	436.5	388.0	427.7	418.9	45.9		
52.5	416.7	414.5	414.5	396.8	434.3	425.5	381.4	418.9	410.1	366.0	401.2	394.6	352.7	388.0	379.2	339.5	370.4	363.8	52.5		
59.1	350.5	346.1	348.3	346.1	366.0	363.8	335.1	363.8	359.4	321.9	352.7	346.1	310.9	339.5	330.7	299.8	324.1	317.5	59.1		
65.6	299.8	297.6	299.8	297.6	313.1	310.9	295.4	310.9	308.6	286.6	306.4	304.2	277.8	299.8	293.2	266.8	288.8	282.2	65.6		
72.2	262.4	260.1	262.4	257.9	271.2	269.0	255.7	269.0	266.8	253.5	266.8	264.6	249.1	264.6	260.1	240.3	257.9	251.3	72.2		
78.7	233.7	229.3	231.5	227.1	240.3	238.1	227.1	238.1	235.9	222.7	233.7	231.5	222.7	231.5	227.1	217.2	227.1	224.9	78.7		
85.3	208.3	205.0	207.2	203.9	213.8	211.6	201.7	211.6	209.4	198.4	207.2	205.0	197.3	205.0	201.7	195.1	200.6	198.4	85.3		
91.9	188.5	185.2	186.3	183.0	191.8	189.6	181.9	189.6	187.4	177.5	185.2	183.0	176.4	183.0	179.7	174.2	178.6	176.4	91.9		
98.4	172.0	167.6	169.8	166.4	173.1	170.9	164.2	170.9	168.7	160.9	166.4	164.2	158.7	164.2	160.9	156.5	159.8	157.6	98.4		
108.3	151.0	147.7	149.1	145.8	151.6	148.5	143.6	148.5	146.3	139.4	145.0	141.9	138.1	141.9	138.6	135.9	136.7	135.0	108.3		
111.5	-	141.1	142.2	138.9	144.4	141.1	136.7	141.1	138.9	132.3	137.8	134.5	131.2	134.5	131.2	129.0	130.1	127.9	111.5		
124.7	-	120.2	121.3	117.9	121.3	119.0	115.7	119.0	116.8	111.3	114.6	112.4	110.2	111.3	109.3	107.8	108.2	105.8	124.7		
137.8	-	-	105.8	102.1	104.7	102.5	99.4	101.9	99.6	95.7	97.7	95.5	93.9	94.6	91.3	91.1	89.7	87.1	137.8		
141.1	-	-	102.5	98.9	101.3	99.0	96.0	98.4	96.1	92.4	94.1	91.7	90.6	90.8	87.1	87.6	85.5	83.3	141.1		
150.9	-	-	-	89.3	91.1	88.6	86.4	88.0	85.5	82.5	83.3	80.5	80.7	79.6	76.1	77.4	74.5	71.9	150.9		
160.8	-	-	-	81.4	82.7	80.2	78.3	79.4	76.6	74.4	74.1	71.4	72.1	70.3	66.8	68.6	65.3	62.4	160.8		
164.0	-	-	-	-	-	77.4	75.6	76.5	73.6	71.7	71.2	68.3	69.2	67.2	63.7	65.7	62.2	59.3	164.0		
167.3	-	-	-	-	-	75.0	73.5	73.9	71.2	69.3	68.7	65.8	66.7	64.7	61.1	63.3	59.4	56.7	167.3		
177.2	-	-	-	-	-	-	67.0	66.6	63.7	62.2	61.3	58.2	59.7	57.1	53.4	56.0	51.8	48.9	177.2		
183.7	-	-	-	-	-	-	-	-	59.3	58.3	57.1	53.9	55.7	52.7	49.1	51.9	47.4	44.6	183.7		
190.3	-	-	-	-	-	-	-	-	-	54.5	52.9	49.8	51.6	48.5	44.8	47.8	43.0	40.3	190.3		
193.6	-	-	-	-	-	-	-	-	-	52.7	50.9	48.1	49.9	46.7	42.9	46.1	41.2	38.4	193.6		
203.4	-	-	-	-	-	-	-	-	-	-	-	42.8	45.0	41.4	37.5	41.0	35.7	32.8	203.4		
210.0	-	-	-	-	-	-	-	-	-	-	-	-	42.1	38.1	34.4	38.0	32.5	29.7	210.0		
216.5	-	-	-	-	-	-	-	-	-	-	-	-	-	-	31.5	35.1	29.3	26.5	216.5		
219.8	-	-	-	-	-	-	-	-	-	-	-	-	-	-	30.0	33.8	28.0	25.0	219.8		
226.4	-	-	-	-	-	-	-	-	-	-	-	-	-	-	-	31.3	25.4	22.4	226.4		
229.7	-	-	-	-	-	-	-	-	-	-	-	-	-	-	-	-	-	21.2	229.7		
236.2	-	-	-	-	-	-	-	-	-	-	-	-	-	-	-	-	-	18.7	236.2		

408,000 lb
 452,000 lb
 496,100 lb
 66,100 lb
 110,200 lb

Operation

LH

+ 27.6 ft 32.2 ft/s 360° ASME B30.5																		
ft <u>275.6</u> <u>285.5</u> <u>295.3</u> <u>305.1</u> <u>315.0</u> <u>324.8</u> <u>334.6</u> <u>344.5</u> <u>354.3</u> <u>364.2</u> <u>374.0</u>																		
ft <u>LH_1</u> <u>LH_5</u> <u>LH_1</u> <u>LH_5</u> <u>LH_1</u> <u>LH_5</u> <u>LH_1</u> <u>LH_5</u> <u>LH_1</u> <u>LH_5</u> <u>LH_1</u> <u>LH_5</u>																		
1,000 lb																		
36.1	456.4	526.9	513.7	421.1	509.3	-	-	-	-	-	-	-	-	-	-	-	-	36.1
39.4	434.3	482.8	471.8	412.3	467.4	458.6	352.7	449.7	438.7	321.9	429.9	-	-	-	-	-	-	39.4
42.7	404.5	447.5	437.6	385.8	434.3	425.5	347.2	417.8	407.9	316.4	400.1	390.2	297.6	381.4	343.9	271.2	324.1	42.7
45.9	374.8	412.3	403.4	359.4	401.2	392.4	341.7	385.8	377.0	310.9	370.4	361.6	295.4	354.9	337.3	269.0	317.5	45.9
52.5	328.5	357.1	348.3	315.3	348.3	341.7	304.2	335.1	328.5	291.0	321.9	315.3	280.0	308.6	308.6	262.4	302.0	52.5
59.1	291.0	313.1	306.4	277.8	306.4	299.8	269.0	295.4	288.8	257.9	282.2	277.8	246.9	271.2	273.4	238.1	269.0	59.1
65.6	260.1	277.8	271.2	249.1	273.4	266.8	240.3	262.4	255.7	231.5	251.3	244.7	222.7	240.3	242.5	212.7	238.1	65.6
72.2	233.7	246.9	242.5	224.9	244.7	238.1	217.2	233.7	229.3	208.3	224.9	220.5	199.5	216.1	218.3	190.7	213.8	72.2
78.7	211.6	222.7	218.3	202.8	220.5	215.0	196.2	211.6	206.1	188.5	201.7	197.3	180.8	194.0	196.2	173.1	192.9	78.7
85.3	192.9	198.4	196.2	185.2	199.5	195.1	178.6	190.7	186.3	170.9	183.0	177.5	164.2	174.2	177.5	156.5	174.2	85.3
91.9	174.2	176.4	174.2	168.7	177.5	175.3	163.1	173.1	168.7	156.5	165.3	160.9	148.8	157.6	160.9	142.2	157.6	91.9
98.4	156.5	157.6	155.4	153.2	158.7	156.5	149.9	156.5	154.3	143.3	149.9	146.6	136.7	143.3	146.6	130.1	143.3	98.4
111.5	129.0	127.9	125.7	125.7	129.0	126.8	124.6	126.8	124.6	120.2	122.4	120.2	114.6	117.9	122.4	108.7	119.0	111.5
124.7	107.8	105.4	103.0	104.5	106.7	104.3	103.6	103.8	101.4	100.3	99.2	96.6	97.4	96.6	100.8	91.5	99.2	124.7
137.8	91.1	86.4	84.0	87.5	87.7	85.1	86.4	84.7	82.2	82.5	80.0	77.6	80.2	77.4	81.6	76.5	80.0	137.8
150.9	77.4	71.2	68.6	73.2	72.3	69.9	72.1	69.4	66.8	68.1	64.6	62.2	65.9	61.9	66.1	61.9	64.4	150.9
164.0	65.5	58.6	56.0	61.5	59.7	57.3	60.2	56.7	54.2	56.2	52.0	49.4	54.0	49.2	53.4	49.8	51.8	164.0
177.2	55.8	48.3	45.6	51.6	49.4	46.7	50.3	46.1	43.7	46.3	41.4	38.8	43.9	38.4	42.8	39.9	41.0	177.2
190.3	47.6	39.5	36.8	43.4	40.6	37.9	41.9	37.3	34.6	37.9	32.4	29.8	35.5	29.5	33.7	31.5	32.0	190.3
203.4	40.6	32.0	29.1	36.2	32.8	30.2	34.8	29.5	26.9	30.6	24.7	22.0	28.2	21.6	26.0	24.3	24.3	203.4
216.5	34.6	25.6	22.7	30.2	26.5	23.8	28.7	22.9	20.3	24.5	18.1	15.4	22.0	15.0	19.2	17.9	17.4	216.5
229.7	29.3	19.8	17.2	24.9	20.7	18.1	23.4	17.2	14.6	19.2	12.3	9.7	16.5	9.0	13.4	12.3	11.7	229.7
236.2	27.1	17.5	14.6	22.6	18.3	15.6	20.9	14.6	12.0	16.8	9.7	-	14.1	-	-	9.9	9.0	236.2
242.8	24.9	15.2	12.3	20.3	15.9	13.2	18.5	12.1	9.5	14.3	-	-	11.7	-	-	-	-	242.8
246.1	23.8	14.1	11.2	19.3	14.8	12.1	17.5	11.0	-	13.3	-	-	10.6	-	-	-	-	246.1
249.3	-	-	10.1	18.4	13.7	11.0	16.5	9.9	-	12.2	-	-	9.5	-	-	-	-	249.3
252.6	-	-	9.0	17.5	12.7	9.9	15.5	8.8	-	11.2	-	-	-	-	-	-	-	252.6
255.9	-	-	-	16.5	11.7	8.8	14.6	-	-	10.1	-	-	-	-	-	-	-	255.9
259.2	-	-	-	15.7	10.7	-	13.6	-	-	9.3	-	-	-	-	-	-	-	259.2
262.5	-	-	-	14.8	9.7	-	12.7	-	-	-	-	-	-	-	-	-	-	262.5
269.0	-	-	-	-	-	-	10.8	-	-	-	-	-	-	-	-	-	-	269.0
275.6	-	-	-	-	-	-	9.3	-	-	-	-	-	-	-	-	-	-	275.6

408,000 lb **452,000 lb** **496,100 lb**
66,100 lb **110,200 lb**

Operation

LH

<div style="display: flex; justify-content: space-between; align-items: center;"> <div style="text-align: center;"> 27.6 ft </div> <div style="text-align: center;"> 32.2 ft/s </div> <div style="text-align: center;"> 360° </div> <div style="text-align: right;"> ASME B30.5 </div> </div>																			
ft		118.1	137.8	157.5	177.2	187.0	196.9	206.7	216.5	226.4	236.2	246.1	255.9	265.8	ft				
		LH_1			LH_5		LH_1	LH_5	LH_1	LH_5	LH_1	LH_5	LH_1	LH_5					
ft		1,000 lb																ft	
23.0	765.0	765.0	-	-	-	-	-	-	-	-	-	-	-	-	-	-	-	-	23.0
26.2	765.0	745.2	701.1	654.8	696.7	674.6	-	-	-	-	-	-	-	-	-	-	-	-	26.2
29.5	694.5	650.4	615.1	579.8	610.7	593.0	546.7	577.6	560.0	515.9	544.5	531.3	-	-	-	-	-	-	29.5
32.8	610.7	575.4	546.7	518.1	542.3	526.9	489.4	513.7	500.4	465.2	487.2	474.0	440.9	463.0	449.7	418.9	438.7	427.7	32.8
39.4	491.6	465.2	447.5	425.5	438.7	429.9	405.7	418.9	410.1	385.8	399.0	390.2	368.2	381.4	370.4	350.5	361.6	352.7	39.4
45.9	401.2	388.0	377.0	359.4	368.2	359.4	343.9	352.7	343.9	328.5	335.1	328.5	313.1	321.9	313.1	299.8	306.4	297.6	45.9
52.5	326.3	324.1	324.1	310.9	315.3	306.4	295.4	302.0	295.4	284.4	288.8	282.2	271.2	275.6	269.0	260.1	262.4	255.7	52.5
59.1	273.4	271.2	271.2	269.0	262.4	260.1	260.1	262.4	255.7	249.1	251.3	244.7	238.1	240.3	233.7	229.3	227.1	222.7	59.1
65.6	233.7	231.5	233.7	229.3	222.7	220.5	227.1	222.7	220.5	220.5	218.3	215.0	212.7	210.5	205.0	202.8	200.6	195.1	65.6
72.2	203.9	200.6	202.8	199.5	192.9	191.8	197.3	191.8	189.6	195.1	187.4	185.2	189.6	185.2	181.9	180.8	176.4	172.0	72.2
78.7	179.7	176.4	178.6	175.3	168.7	166.4	173.1	166.4	165.3	169.8	163.1	160.9	168.7	160.9	157.6	163.1	156.5	153.2	78.7
85.3	159.8	156.5	158.7	155.4	148.8	146.6	153.2	146.6	144.4	149.9	143.3	141.1	148.8	140.0	137.8	146.6	136.7	134.5	85.3
91.9	144.4	141.1	142.2	138.9	132.3	130.1	136.7	130.1	127.9	133.4	126.8	124.6	132.3	123.5	121.3	130.1	120.2	117.9	91.9
98.4	130.1	126.8	129.0	125.7	119.0	116.8	123.5	116.8	114.6	119.0	112.4	110.2	117.9	110.2	107.4	115.7	106.3	103.8	98.4
108.3	113.5	111.1	112.6	109.1	102.7	100.5	106.9	100.3	98.1	103.2	96.1	93.7	101.6	93.0	89.8	99.2	88.0	85.5	108.3
111.5	-	105.8	107.1	103.6	97.2	95.0	101.4	94.8	92.6	97.9	90.6	88.2	96.1	87.3	84.0	93.7	82.7	80.0	111.5
124.7	-	89.5	90.6	87.1	80.7	78.3	84.7	77.8	75.2	80.9	73.0	70.1	79.4	69.4	65.9	76.1	64.6	61.9	124.7
137.8	-	-	78.0	74.3	67.2	64.4	71.4	63.9	61.3	67.2	58.9	56.2	65.3	55.3	51.8	61.9	50.3	47.6	137.8
141.1	-	-	75.4	71.7	64.6	61.7	68.7	61.2	58.5	64.5	56.1	53.4	62.4	52.4	48.7	59.1	47.2	44.8	141.1
150.9	-	-	-	63.9	56.7	53.6	60.6	52.9	50.0	56.2	47.8	45.0	54.0	43.9	40.3	50.5	39.0	36.2	150.9
160.8	-	-	-	57.5	50.0	47.1	54.0	46.1	43.4	49.4	40.9	38.2	47.1	37.1	33.4	43.5	31.9	29.2	160.8
164.0	-	-	-	-	-	45.0	51.8	43.9	41.2	47.2	38.8	35.9	44.8	34.8	31.1	41.2	29.5	26.9	164.0
167.3	-	-	-	-	-	43.2	50.0	42.0	39.4	45.3	36.9	34.1	42.8	32.9	29.2	39.3	27.6	24.7	167.3
177.2	-	-	-	-	-	-	44.5	36.8	33.7	39.7	31.3	28.4	37.3	27.1	23.6	33.5	21.8	19.2	177.2
183.7	-	-	-	-	-	-	-	-	30.6	36.6	28.2	25.2	34.1	23.8	20.4	30.3	18.6	15.9	183.7
190.3	-	-	-	-	-	-	-	-	-	33.5	25.1	22.3	30.9	20.9	17.2	27.1	15.4	12.6	190.3
193.6	-	-	-	-	-	-	-	-	-	32.2	23.8	21.0	29.5	19.6	15.9	25.7	14.1	11.1	193.6
196.9	-	-	-	-	-	-	-	-	-	-	-	19.7	28.2	18.3	14.6	24.4	12.7	9.7	196.9
203.4	-	-	-	-	-	-	-	-	-	-	-	17.2	25.6	15.7	11.9	21.6	9.9	-	203.4
210.0	-	-	-	-	-	-	-	-	-	-	-	-	23.4	13.2	9.5	19.3	-	-	210.0
216.5	-	-	-	-	-	-	-	-	-	-	-	-	-	-	-	17.0	-	-	216.5
226.4	-	-	-	-	-	-	-	-	-	-	-	-	-	-	-	14.1	-	-	226.4

275,600 lb 363,800 lb

Operation

LH

 27.6 ft 32.2 ft/s 360° ASME B30.5																		
 ft 275.6 285.5 295.3 305.1 315.0 324.8 334.6 344.5 354.3 364.2 374.0 																		
 LH_1 LH_5 LH_1 LH_5 LH_1 LH_5 LH_1 LH_5 LH_1 LH_5 LH_1 LH_5 																		
ft 1,000 lb ft																		
36.1	366.0	379.2	370.4	348.3	366.0	-	-	-	-	-	-	-	-	-	-	-	-	36.1
39.4	337.3	346.1	337.3	321.9	335.1	326.3	308.6	319.7	313.1	293.2	304.2	-	-	-	-	-	-	39.4
42.7	313.1	319.7	310.9	298.7	309.7	302.0	286.6	295.4	288.8	273.4	282.2	273.4	260.1	266.8	269.0	246.9	262.4	42.7
45.9	288.8	293.2	284.4	275.6	284.4	277.8	264.6	271.2	264.6	253.5	260.1	253.5	240.3	246.9	246.9	229.3	242.5	45.9
52.5	251.3	251.3	244.7	240.3	244.7	238.1	231.5	233.7	229.3	220.5	222.7	218.3	210.5	212.7	215.0	200.6	209.4	52.5
59.1	220.5	218.3	212.7	211.6	213.8	208.3	203.9	203.9	199.5	194.0	194.0	189.6	185.2	185.2	187.4	176.4	183.0	59.1
65.6	197.3	190.7	186.3	188.5	188.5	183.0	180.8	179.7	174.2	172.0	169.8	165.3	164.2	162.0	164.2	155.4	160.9	65.6
72.2	176.4	168.7	164.2	167.6	166.4	162.0	162.0	158.7	153.2	154.3	149.9	145.5	146.6	142.2	144.4	138.9	141.1	72.2
78.7	158.7	149.9	145.5	151.0	147.7	143.3	145.5	140.0	136.7	137.8	132.3	127.9	131.2	124.6	127.9	123.5	124.6	78.7
85.3	143.3	133.4	129.0	136.7	132.3	127.9	131.2	124.6	121.3	123.5	117.9	113.5	117.9	110.2	113.5	110.2	111.3	85.3
91.9	130.1	117.9	115.7	123.5	117.9	114.6	117.9	111.3	108.5	111.3	104.9	101.2	106.0	98.3	101.9	99.4	99.0	91.9
98.4	115.7	103.6	101.0	112.4	104.9	102.3	107.8	100.5	96.8	101.6	93.5	89.9	95.7	87.1	90.8	89.3	88.2	98.4
111.5	93.7	79.6	76.9	90.4	80.9	78.3	89.3	78.0	75.6	83.6	73.4	71.0	78.0	68.3	72.5	72.3	69.9	111.5
124.7	76.1	61.3	58.9	72.1	62.6	60.2	71.0	59.7	57.1	67.2	55.1	52.5	63.9	52.5	56.7	58.2	55.1	124.7
137.8	61.9	47.2	44.5	58.0	48.3	45.6	56.7	45.4	42.8	52.9	40.8	38.1	50.7	37.9	42.1	46.7	40.6	137.8
150.9	50.5	35.7	33.1	46.3	36.8	34.2	45.2	33.7	31.1	41.2	29.1	26.5	39.0	26.2	30.4	35.1	28.9	150.9
164.0	41.0	26.2	23.6	37.0	27.3	24.7	35.7	24.3	21.6	31.7	19.4	17.0	29.5	16.5	20.9	25.4	19.2	164.0
173.9	35.2	20.3	17.6	31.1	21.4	18.7	29.8	18.3	15.7	25.8	13.4	10.9	23.4	10.4	14.8	19.4	13.2	173.9
177.2	33.3	18.3	15.7	29.1	19.4	16.8	27.8	16.3	13.7	23.8	11.5	8.8	21.4	-	12.8	17.4	11.2	177.2
180.4	31.6	16.6	14.0	27.4	17.7	15.1	26.0	14.6	11.9	22.2	9.7	-	19.7	-	11.0	15.7	9.3	180.4
183.7	30.0	15.0	12.3	25.8	16.1	13.4	24.3	12.9	10.1	20.5	-	-	18.1	-	9.3	14.0	-	183.7
190.3	26.7	11.7	9.0	22.5	12.8	10.1	21.2	9.5	-	17.2	-	-	14.8	-	-	10.6	-	190.3
193.6	25.3	10.3	-	21.1	11.4	-	19.7	-	-	15.7	-	-	13.3	-	-	9.0	-	193.6
196.9	23.9	8.8	-	19.7	9.9	-	18.3	-	-	14.2	-	-	11.8	-	-	-	-	196.9
203.4	21.2	-	-	17.0	-	-	15.4	-	-	11.2	-	-	8.8	-	-	-	-	203.4
206.7	20.0	-	-	15.8	-	-	14.2	-	-	10.1	-	-	-	-	-	-	-	206.7
216.5	16.3	-	-	12.1	-	-	10.6	-	-	-	-	-	-	-	-	-	-	216.5
219.8	15.3	-	-	11.0	-	-	9.5	-	-	-	-	-	-	-	-	-	-	219.8
226.4	13.3	-	-	8.8	-	-	-	-	-	-	-	-	-	-	-	-	-	226.4
229.7	12.3	-	-	-	-	-	-	-	-	-	-	-	-	-	-	-	-	229.7
242.8	8.8	-	-	-	-	-	-	-	-	-	-	-	-	-	-	-	-	242.8

363,800 lb

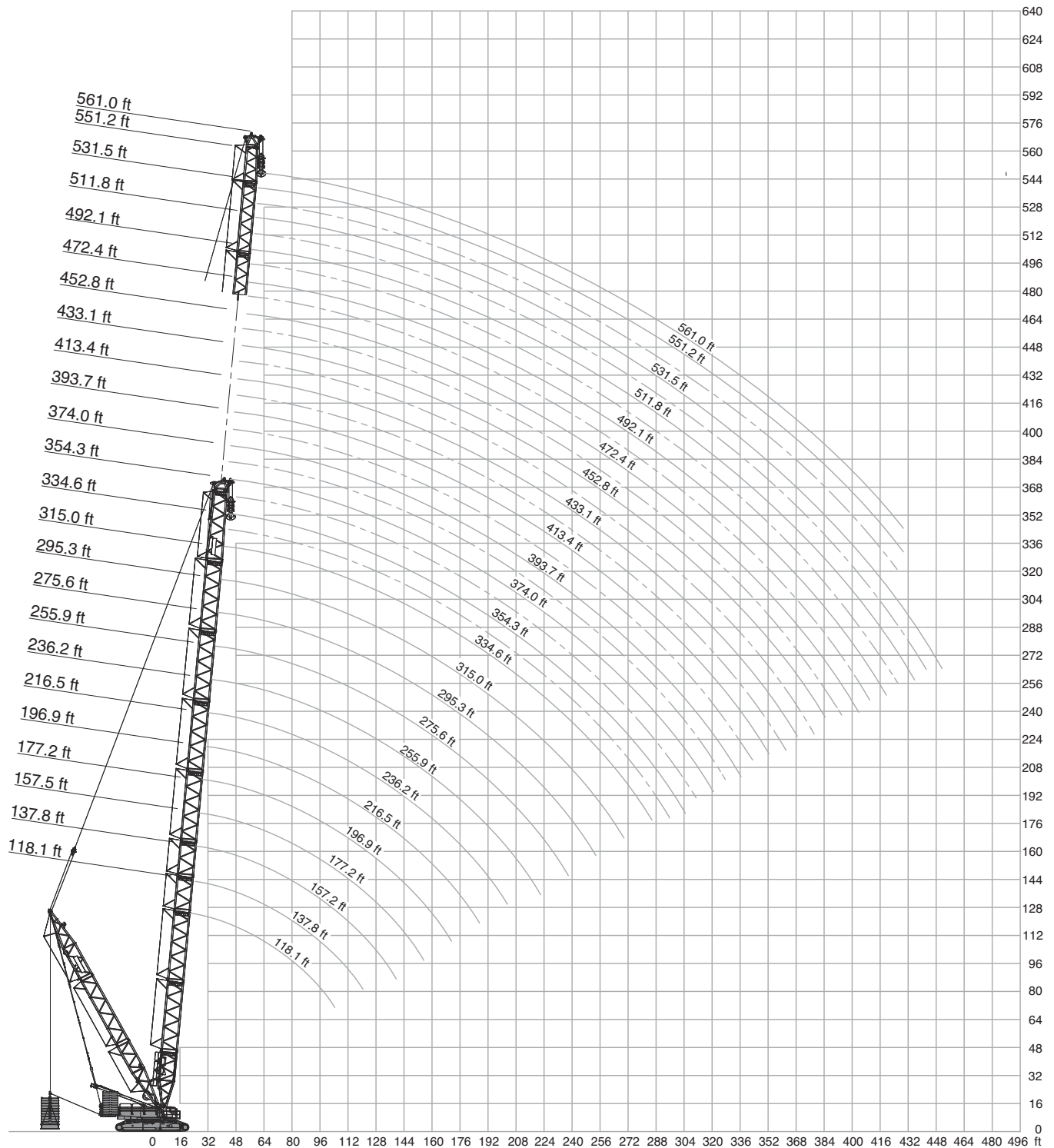

Operation

SSL

496,100 lb + 110,200 lb 36.1-68.9 ft 27.6 ft 32.2 ft/s 360° ASME B30.5										
137.8 ft 157.5 ft										
SSL_2 SSL_3 SSL_2 SSL_3										
0 lb 0 lb -716.6 klb 0 lb 0 lb -716.6 klb										
1,000 lb										
29.5	976.6	-	-	-	941.4	-	-	-	-	29.5
32.8	877.4	-	-	-	842.2	-	-	-	-	32.8
36.1	792.6	-	-	-	761.7	1353.6	1353.6	-	-	36.1
39.4	714.3	-	-	-	690.0	1362.5	1362.5	-	-	39.4
45.9	593.0	-	-	-	584.2	1274.3	1272.1	-	-	45.9
52.5	489.4	1139.8	-	-	491.6	1203.7	1203.7	-	-	52.5
59.1	414.5	1091.3	-	-	412.3	1084.7	1082.5	-	-	59.1
65.6	354.9	992.1	-	-	352.7	985.5	983.3	-	-	65.6
72.2	310.9	908.3	-	-	306.4	901.7	899.5	-	-	72.2
78.7	273.4	835.6	-	-	269.0	831.1	828.9	-	-	78.7
85.3	244.7	776.0	-	-	240.3	769.4	767.2	-	-	85.3
91.9	220.5	709.9	-	-	216.1	714.3	712.1	-	-	91.9
98.4	200.6	639.3	-	-	196.2	663.6	661.4	-	-	98.4
111.5	170.5	529.8	-	-	165.3	573.9	573.2	-	-	111.5
124.7	143.3	443.1	-	-	140.0	485.8	485.0	-	-	124.7
137.8	-	-	-	-	120.2	410.1	410.1	-	-	137.8
144.4	-	-	-	-	112.4	372.6	372.6	-	-	144.4

177.2 ft 196.9 ft										
SSL_1 SSL_2 SSL_3 SSL_4 SSL_1 SSL_2 SSL_3 SSL_4										
0 lb 0 lb -716.6 klb 0 lb 0 lb -716.6 klb										
1,000 lb										
26.2	956.8	1433.0	-	1393.3	-	-	-	-	-	26.2
29.5	846.6	1433.0	-	1393.3	806.9	1258.8	1258.8	1258.8	1258.8	29.5
32.8	758.4	1433.0	-	1393.3	734.1	1258.8	1258.8	1258.8	1258.8	32.8
36.1	698.9	1433.0	1375.7	1393.3	671.3	1258.8	1258.8	1258.8	1258.8	36.1
39.4	637.1	1433.0	1393.3	1393.3	608.5	1258.8	1258.8	1258.8	1258.8	39.4
45.9	540.1	1269.9	1347.0	1344.8	515.9	1258.8	1258.8	1258.8	1258.8	45.9
52.5	467.4	1128.8	1199.3	1197.1	447.5	1124.4	1194.9	1192.7	1190.5	52.5
59.1	405.7	1016.3	1078.1	1078.1	392.4	1009.7	1073.7	1071.4	1069.2	59.1
65.6	348.3	921.5	978.9	978.9	343.9	917.1	974.4	972.2	970.0	65.6
72.2	302.0	844.4	895.1	895.1	297.6	837.8	892.9	890.7	888.5	72.2
78.7	264.6	776.0	824.5	824.5	262.4	771.6	820.1	817.9	815.7	78.7
85.3	235.9	718.7	762.8	762.8	231.5	714.3	760.6	758.4	756.2	85.3
91.9	212.7	668.0	707.7	707.7	208.3	663.6	703.3	703.3	701.1	91.9
98.4	191.8	621.7	657.0	657.0	187.4	615.1	654.8	652.6	650.4	98.4
111.5	160.9	545.3	576.1	576.1	157.3	541.6	573.9	573.2	571.0	111.5
124.7	135.6	476.9	505.6	505.6	131.9	476.2	504.1	503.4	501.2	124.7
137.8	115.7	416.7	445.3	445.3	111.3	418.9	445.3	443.1	440.9	137.8
150.9	101.6	353.5	377.7	376.3	96.6	374.8	401.2	400.5	398.3	150.9
160.8	91.7	317.5	339.5	339.5	86.5	340.2	366.0	365.6	363.4	160.8
164.0	-	-	-	-	83.8	327.8	352.7	352.0	349.8	164.0
177.2	-	-	-	-	72.8	288.8	308.6	306.4	304.2	177.2

0 lb 143,300 lb 275,600 lb 363,800 lb 452,000 lb 540,200 lb 628,400 lb 716,600 lb

SSL_1: 36.1 ft – 62.3 ft

SSL_2, SSL_3, SSL_4: 36.1 ft – 68.9 ft

Operation

SSL

496,100 lb + 110,200 lb 36.1-68.9 ft 27.6 ft 32.2 ft/s 360° ASME B30.5															
216.5 ft						236.2 ft									
SSL_1		SSL_2		SSL_3		SSL_4		SSL_1		SSL_2		SSL_3		SSL_4	
0 lb		0 lb - 716.6 klb				0 lb		0 lb - 716.6 klb							
ft	1,000 lb										ft				
32.8	698.9	1122.2	1122.2	1122.2	1122.2	663.6	981.1	981.1	981.1	981.1	981.1	981.1	981.1	981.1	32.8
39.4	582.0	1117.7	1122.2	1122.2	1122.2	555.6	981.1	981.1	981.1	981.1	981.1	981.1	981.1	981.1	39.4
45.9	496.0	1106.7	1122.2	1122.2	1122.2	476.2	981.1	981.1	981.1	981.1	981.1	981.1	981.1	981.1	45.9
52.5	432.1	1093.5	1115.5	1122.2	1122.2	414.5	978.9	981.1	981.1	981.1	981.1	981.1	981.1	981.1	52.5
59.1	379.2	1009.7	1071.4	1067.0	1064.8	366.0	963.4	974.4	981.1	981.1	981.1	981.1	981.1	981.1	59.1
65.6	337.3	914.9	972.2	967.8	965.6	326.3	912.7	965.6	963.4	959.0	959.0	959.0	959.0	959.0	65.6
72.2	297.6	837.8	890.7	886.3	884.1	293.2	833.3	886.3	881.8	877.4	877.4	877.4	877.4	877.4	72.2
78.7	262.4	769.4	817.9	813.5	813.5	260.1	765.0	815.7	811.3	806.9	806.9	806.9	806.9	806.9	78.7
85.3	231.5	712.1	758.4	754.0	751.8	229.3	707.7	754.0	749.6	745.2	745.2	745.2	745.2	745.2	85.3
91.9	208.3	661.4	703.3	698.9	696.7	206.1	657.0	698.9	694.5	690.0	690.0	690.0	690.0	690.0	91.9
98.4	187.4	615.1	652.6	648.2	646.0	185.2	610.7	648.2	643.8	639.3	639.3	639.3	639.3	639.3	98.4
111.5	156.5	540.1	573.2	570.3	568.1	153.6	537.2	568.8	565.9	561.4	561.4	561.4	561.4	561.4	111.5
124.7	130.8	474.7	504.1	501.2	499.0	127.6	472.5	500.4	497.5	493.8	493.8	493.8	493.8	493.8	124.7
137.8	110.2	418.9	445.3	440.9	438.7	107.4	416.7	443.1	438.7	436.5	436.5	436.5	436.5	436.5	137.8
150.9	95.1	377.7	401.2	396.8	396.1	91.6	375.5	399.0	394.6	392.4	392.4	392.4	392.4	392.4	150.9
164.0	81.8	340.2	362.3	357.9	357.9	77.8	338.8	360.1	355.7	353.5	353.5	353.5	353.5	353.5	164.0
177.2	70.3	306.4	328.5	324.1	324.1	65.9	306.4	326.3	321.9	319.7	319.7	319.7	319.7	319.7	177.2
190.3	61.7	264.1	286.2	281.8	280.0	57.1	278.5	299.8	295.4	291.7	291.7	291.7	291.7	291.7	190.3
193.6	59.5	257.9	275.6	271.2	269.0	54.9	271.5	293.2	288.8	284.8	284.8	284.8	284.8	284.8	193.6
203.4	-	-	-	-	-	49.2	246.9	269.0	264.6	260.1	260.1	260.1	260.1	260.1	203.4
210.0	-	-	-	-	-	45.6	229.3	251.3	246.9	242.5	242.5	242.5	242.5	242.5	210.0

255.9 ft 275.6 ft															
SSL_1				SSL_2				SSL_3				SSL_4			
0 lb		0 lb - 716.6 klb				0 lb		0 lb - 716.6 klb							
ft	1,000 lb										ft				
36.1	579.8	828.9	-	910.5	910.5	553.4	745.2	-	837.8	837.8	837.8	837.8	837.8	837.8	36.1
39.4	533.5	828.9	-	910.5	910.5	511.5	745.2	-	837.8	837.8	837.8	837.8	837.8	837.8	39.4
42.7	496.0	828.9	842.2	910.5	910.5	476.2	745.2	-	837.8	837.8	837.8	837.8	837.8	837.8	42.7
45.9	458.6	828.9	848.8	910.5	910.5	440.9	745.2	754.0	837.8	837.8	837.8	837.8	837.8	837.8	45.9
52.5	401.2	828.9	842.2	910.5	910.5	385.8	745.2	762.8	837.8	837.8	837.8	837.8	837.8	837.8	52.5
59.1	354.9	813.5	833.3	910.5	910.5	339.5	745.2	754.0	837.8	837.8	837.8	837.8	837.8	837.8	59.1
65.6	315.3	809.1	826.7	910.5	910.5	304.2	731.9	745.2	837.8	837.8	837.8	837.8	837.8	837.8	65.6
72.2	284.4	802.5	820.1	877.4	873.0	273.4	725.3	738.5	837.8	837.8	837.8	837.8	837.8	837.8	72.2
78.7	257.9	765.0	802.5	804.7	802.5	246.9	718.7	731.9	800.3	795.9	795.9	795.9	795.9	795.9	78.7
85.3	229.3	707.7	754.0	745.2	740.8	224.9	703.3	707.7	738.5	736.3	736.3	736.3	736.3	736.3	85.3
91.9	206.1	657.0	698.9	690.0	685.6	202.8	652.6	692.3	685.6	681.2	681.2	681.2	681.2	681.2	91.9
98.4	185.2	610.7	648.2	639.3	634.9	181.9	606.3	643.8	634.9	630.5	630.5	630.5	630.5	630.5	98.4
111.5	153.6	535.7	570.3	561.4	557.0	151.0	531.3	565.9	555.6	552.6	552.6	552.6	552.6	552.6	111.5
124.7	127.6	471.8	501.9	493.8	490.2	124.9	467.4	497.5	488.0	485.0	485.0	485.0	485.0	485.0	124.7
137.8	107.1	418.9	443.1	436.5	434.3	103.6	414.5	438.7	432.1	427.7	427.7	427.7	427.7	427.7	137.8
150.9	91.3	376.3	399.0	392.4	388.7	87.5	373.3	396.1	388.0	385.1	385.1	385.1	385.1	385.1	150.9
164.0	77.3	338.8	360.1	353.5	349.1	73.3	336.6	357.9	349.1	346.9	346.9	346.9	346.9	346.9	164.0
177.2	65.3	306.4	326.3	319.7	315.3	61.3	304.2	324.1	315.3	313.1	313.1	313.1	313.1	313.1	177.2
190.3	56.1	281.5	299.8	291.7	288.8	51.9	277.8	296.2	288.8	286.6	286.6	286.6	286.6	286.6	190.3
203.4	48.0	257.2	275.6	267.5	264.6	43.6	254.3	271.2	264.6	262.4	262.4	262.4	262.4	262.4	203.4
216.5	40.8	233.7	253.5	246.9	242.5	36.4	233.7	249.1	242.5	240.3	240.3	240.3	240.3	240.3	216.5
229.7	35.3	205.0	224.9	216.1	211.6	30.6	213.8	231.5	224.9	221.2	221.2	221.2	221.2	221.2	229.7
242.8	-	-	-	-	-	25.3	191.4	210.9	202.1	197.7	197.7	197.7	197.7	197.7	242.8
246.1	-	-	-	-	-	24.0	185.2	205.0	195.1	190.7	190.7	190.7	190.7	190.7	246.1

0 lb 143,300 lb 275,600 lb 363,800 lb 452,000 lb 540,200 lb 628,400 lb 716,600 lb

SSL_1:  36.1 ft - 62.3 ft

SSL_2, SSL_3, SSL_4:  36.1 ft - 68.9 ft

496,100 lb + 110,200 lb 36.1-68.9 ft 27.6 ft 32.2 ft/s 360° ASME B30.5											
295.3 ft						315.0 ft					
SSL_1		SSL_2		SSL_3		SSL_4		SSL_1		SSL_2	
0 lb		0 lb - 716.6 klb				0 lb		0 lb - 716.6 klb			
ft	1,000 lb										ft
39.4	493.8	668.0	-	765.0	765.0	471.8	590.8	-	692.3	692.3	39.4
45.9	425.5	668.0	674.6	765.0	765.0	407.9	590.8	-	692.3	692.3	45.9
49.2	399.0	668.0	683.4	765.0	765.0	383.6	590.8	597.5	692.3	692.3	49.2
52.5	372.6	668.0	683.4	765.0	765.0	359.4	590.8	604.1	692.3	692.3	52.5
59.1	330.7	668.0	683.4	765.0	765.0	317.5	590.8	604.1	692.3	692.3	59.1
65.6	295.4	668.0	674.6	765.0	765.0	284.4	590.8	604.1	692.3	692.3	65.6
72.2	266.8	659.2	665.8	765.0	765.0	255.7	588.6	597.5	692.3	692.3	72.2
78.7	240.3	652.6	659.2	765.0	765.0	231.5	582.0	590.8	692.3	692.3	78.7
85.3	220.5	646.0	648.2	734.1	731.9	211.6	577.6	586.4	692.3	692.3	85.3
91.9	201.7	632.7	630.5	681.2	676.8	192.9	571.0	573.2	672.4	672.4	91.9
98.4	181.9	606.3	617.3	630.5	626.1	176.4	562.2	557.8	626.1	623.9	98.4
111.5	151.0	531.3	557.0	552.6	548.2	147.0	512.9	534.3	548.2	544.5	111.5
124.7	125.0	467.4	498.2	485.0	481.3	121.6	464.4	494.6	480.6	476.9	124.7
137.8	103.8	414.5	440.9	427.7	425.5	100.3	410.1	438.7	423.3	421.1	137.8
150.9	87.5	373.3	396.8	385.1	382.9	84.0	368.9	393.2	380.7	378.5	150.9
164.0	73.3	336.6	357.9	346.9	344.7	69.7	332.9	354.2	342.5	340.2	164.0
177.2	61.1	304.2	324.1	313.1	310.9	57.5	302.0	321.9	308.6	306.4	177.2
190.3	51.7	279.3	296.2	285.1	282.9	48.0	275.6	293.9	282.2	280.0	190.3
203.4	43.2	255.7	271.9	260.9	257.9	39.5	252.1	269.0	257.9	255.7	203.4
216.5	35.7	233.7	251.3	240.3	235.9	32.0	231.5	246.9	235.9	233.7	216.5
229.7	29.8	217.5	232.2	221.9	219.0	25.8	214.6	229.3	218.3	216.1	229.7
242.8	24.5	200.3	215.3	205.0	201.7	20.3	199.2	213.1	202.1	199.5	242.8
255.9	19.8	181.9	200.6	188.5	184.1	15.4	185.2	198.4	187.4	184.1	255.9
262.5	17.9	170.9	190.7	176.4	172.0	13.3	176.9	190.7	179.3	176.0	262.5
269.0	-	-	-	-	-	11.2	168.7	183.0	171.2	167.9	269.0
278.9	-	-	-	-	-	-	154.3	170.9	157.6	154.3	278.9

334.6 ft												354.3 ft			
SSL_1		SSL_2		SSL_3		SSL_4		SSL_1		SSL_2					
0 lb		0 lb - 716.6 klb				0 lb		0 lb - 716.6 klb							
ft	1,000 lb										ft				
42.7	421.1	522.5	-	-	692.3	403.4	460.8	-	-	619.5	42.7				
45.9	392.4	522.5	-	-	692.3	377.0	460.8	-	-	619.5	45.9				
52.5	346.1	522.5	529.1	676.8	692.3	330.7	460.8	467.4	608.5	619.5	52.5				
59.1	306.4	522.5	535.7	676.8	692.3	293.2	458.6	471.8	617.3	619.5	59.1				
65.6	273.4	522.5	535.7	668.0	692.3	262.4	458.6	471.8	608.5	619.5	65.6				
72.2	246.9	518.1	535.7	659.2	692.3	235.9	456.4	469.6	601.9	619.5	72.2				
78.7	222.7	513.7	529.1	652.6	690.0	213.8	449.7	465.2	595.2	619.5	78.7				
85.3	202.8	509.3	524.7	648.2	683.4	194.0	443.1	460.8	588.6	619.5	85.3				
91.9	185.2	504.9	515.9	641.5	648.2	177.5	438.7	456.4	586.4	617.3	91.9				
98.4	169.8	500.4	502.7	610.7	615.1	162.0	434.3	447.5	577.6	590.8	98.4				
111.5	144.0	474.7	489.4	541.6	540.1	137.1	419.6	435.0	527.6	530.6	111.5				
124.7	120.1	447.5	468.1	478.4	474.7	114.6	400.5	418.9	474.7	471.8	124.7				
137.8	97.9	407.9	434.3	421.1	418.9	94.8	385.8	401.2	418.9	414.5	137.8				
150.9	81.4	368.2	391.7	379.9	376.3	78.3	357.9	379.2	376.3	371.8	150.9				
164.0	67.0	332.2	353.5	342.5	338.8	63.9	328.5	351.3	338.0	334.4	164.0				
177.2	54.7	299.8	319.7	308.6	306.4	51.6	297.6	317.5	304.2	302.0	177.2				
190.3	45.1	274.8	291.7	282.2	280.0	41.9	272.6	291.0	277.8	275.6	190.3				
203.4	36.5	251.3	266.8	257.9	255.7	33.1	249.1	266.0	253.5	251.8	203.4				
216.5	28.9	229.3	244.7	235.9	233.7	25.4	227.1	242.5	231.5	229.3	216.5				
229.7	22.7	212.4	227.8	217.2	214.4	19.2	210.2	224.9	213.8	211.6	229.7				
242.8	17.0	196.9	211.6	200.6	198.4	13.3	194.4	208.0	197.3	195.1	242.8				
246.1	15.8	193.5	207.8	196.8	194.6	11.9	190.7	203.9	193.5	191.3	246.1				
255.9	11.9	183.0	196.2	185.2	183.0	-	179.7	192.9	181.9	179.7	255.9				
269.0	-	170.5	183.0	172.7	170.5	-	167.2	180.4	169.4	166.4	269.0				
282.2	-	155.8	168.7	159.1	156.5	-	155.1	166.4	157.6	154.0	282.2				
295.3	-	138.9	153.2	144.4	141.1	-	143.3	151.0	146.6	142.2	295.3				
308.4	-	-	-	-	-	-	127.9	135.6	131.2	129.3	308.4				
315.0	-	-	-	-	-	-	120.2	127.9	123.5	121.3	315.0				

SSL_1															
1,000 lb															
ft															ft
23.0	1175.1	1433.0	1080.3	1433.0	-	-	-	-	-	-	-	-	-	-	23.0
26.2	994.3	1433.0	923.7	1433.0	859.8	1433.0	806.9	1433.0	-	-	-	-	-	-	26.2
29.5	859.8	1433.0	804.7	1433.0	756.2	1433.0	712.1	1433.0	670.2	1258.8	-	-	-	-	29.5
32.8	756.2	1433.0	712.1	1433.0	672.4	1433.0	637.1	1433.0	601.9	1258.8	573.2	1122.2	542.3	981.1	32.8
39.4	608.5	1433.0	577.6	1433.0	549.0	1426.4	522.5	1422.0	498.2	1258.8	476.2	1117.7	454.2	981.1	39.4
45.9	500.4	1265.5	482.8	1258.8	460.8	1252.2	440.9	1247.8	421.1	1241.2	403.4	1100.1	385.8	981.1	45.9
52.5	407.9	1126.6	403.4	1122.2	394.6	1115.5	379.2	1108.9	363.8	1104.5	350.5	1093.5	335.1	972.2	52.5
59.1	341.7	1014.1	337.3	1009.7	335.1	1003.1	330.7	998.7	317.5	992.1	306.4	992.1	293.2	963.4	59.1
65.6	291.0	923.7	288.8	917.1	284.4	910.5	282.2	906.1	277.8	899.5	271.2	899.5	260.1	895.1	65.6
72.2	253.5	844.4	251.3	840.0	246.9	833.3	242.5	828.9	240.3	822.3	240.3	822.3	233.7	817.9	72.2
78.7	224.9	758.4	220.5	773.8	217.2	767.2	213.8	762.8	209.4	756.2	209.4	756.2	207.2	751.8	78.7
85.3	200.6	674.6	196.2	712.1	192.9	707.7	188.5	701.1	185.2	696.7	185.2	694.5	183.0	692.3	85.3
91.9	180.8	612.9	176.4	659.2	172.0	654.8	168.7	648.2	164.2	643.8	164.2	641.5	162.0	639.3	91.9
98.4	163.1	544.5	159.8	606.3	155.4	608.5	151.0	601.9	147.7	597.5	146.6	595.2	144.4	593.0	98.4
108.3	143.3	465.2	141.1	523.6	136.1	553.4	132.3	547.8	128.5	543.4	127.6	541.2	125.2	537.9	108.3
111.5	-	-	134.8	496.0	129.7	535.0	126.0	529.8	122.1	525.4	121.3	523.2	118.8	519.6	111.5
124.7	-	-	112.4	410.1	108.8	457.1	105.1	466.6	100.6	462.2	99.7	460.0	96.8	456.4	124.7
137.8	-	-	-	-	92.8	385.8	88.2	412.3	83.1	407.9	81.8	405.7	78.3	403.4	137.8
144.4	-	-	-	-	86.4	350.5	82.1	382.1	76.8	386.5	75.3	385.1	71.7	382.1	144.4
150.9	-	-	-	-	-	-	76.0	352.0	70.5	365.2	68.9	364.5	65.0	360.8	150.9
160.8	-	-	-	-	-	-	67.5	315.3	61.9	332.9	60.0	335.8	56.0	331.4	160.8
164.0	-	-	-	-	-	-	-	-	59.7	321.9	57.6	327.8	53.6	323.3	164.0
177.2	-	-	-	-	-	-	-	-	50.7	277.8	48.1	295.4	43.9	291.0	177.2
190.3	-	-	-	-	-	-	-	-	-	-	41.0	261.9	36.5	267.5	190.3
193.6	-	-	-	-	-	-	-	-	-	-	39.2	253.5	34.7	261.6	193.6
203.4	-	-	-	-	-	-	-	-	-	-	-	-	30.0	242.5	203.4
210.0	-	-	-	-	-	-	-	-	-	-	-	-	27.1	229.3	210.0

	0 lb	275,600 lb	363,800 lb	452,000 lb	540,200 lb	628,400 lb	716,600 lb
--	------	------------	------------	------------	------------	------------	------------

Operation







SSL

363,800 lb + 110,200 lb 36.1-62.3 ft 27.6 ft 32.2 ft/s 360° ASME B30.5													
255.9 ft 275.6 ft 295.3 ft 315.0 ft 334.6 ft 354.3 ft													
SSL_1													
0 lb 0 lb-716.6 klb 0 lb 0 lb-716.6 klb 0 lb 0 lb-716.6 klb 0 lb 0 lb-716.6 klb 0 lb 0 lb-716.6 klb 0 lb 0 lb-716.6 klb 0 lb 0 lb-716.6 klb													
1,000 lb													
ft													ft
36.1	474.0	828.9	451.9	745.2	-	-	-	-	-	-	-	-	36.1
39.4	434.3	828.9	414.5	745.2	399.0	668.0	381.4	590.8	-	-	-	-	39.4
42.7	403.4	828.9	384.7	745.2	371.5	668.0	354.9	590.8	339.5	522.5	324.1	460.8	42.7
45.9	372.6	828.9	354.9	745.2	343.9	668.0	328.5	590.8	315.3	522.5	302.0	460.8	45.9
52.5	324.1	820.1	308.6	745.2	299.8	668.0	286.6	590.8	275.6	522.5	262.4	460.8	52.5
59.1	284.4	813.5	273.4	736.3	264.6	668.0	253.5	590.8	242.5	522.5	231.5	458.6	59.1
65.6	251.3	809.1	242.5	729.7	235.9	659.2	224.9	590.8	216.1	522.5	206.1	458.6	65.6
72.2	224.9	802.5	216.1	725.3	210.5	652.6	201.7	588.6	192.9	518.1	184.1	456.4	72.2
78.7	203.9	751.8	195.1	718.7	189.6	648.2	180.8	582.0	173.1	513.7	165.3	449.7	78.7
85.3	183.0	692.3	176.4	687.8	172.0	643.8	164.2	577.6	156.5	507.1	148.8	443.1	85.3
91.9	162.0	637.1	158.7	632.7	156.5	632.7	148.8	571.0	141.1	502.7	133.4	438.7	91.9
98.4	144.4	590.8	142.2	586.4	142.2	586.4	134.5	555.6	127.9	500.4	121.3	434.3	98.4
111.5	118.8	518.8	115.7	514.4	115.9	514.4	111.3	501.2	107.3	474.7	101.0	417.4	111.5
124.7	96.7	456.4	93.1	451.9	93.3	451.9	90.2	448.3	87.5	443.1	82.5	400.5	124.7
137.8	78.0	403.4	74.3	399.0	74.5	399.0	71.2	396.8	68.6	394.6	65.7	385.8	137.8
150.9	64.7	360.8	60.9	356.4	61.0	356.4	57.5	354.2	54.9	352.0	51.9	347.6	150.9
164.0	53.1	323.3	49.2	319.7	49.2	319.7	45.6	316.7	42.9	314.5	39.8	312.3	164.0
177.2	43.2	291.0	39.0	288.8	39.0	288.8	35.3	284.4	32.6	282.2	29.3	280.0	177.2
190.3	35.6	266.0	31.4	263.8	31.1	262.4	27.3	259.4	24.5	257.2	21.2	255.0	190.3
203.4	28.8	244.0	24.5	241.0	24.0	239.6	20.3	237.0	17.2	234.6	13.8	230.8	203.4
206.7	27.3	239.2	23.0	235.9	22.5	234.8	18.7	232.0	15.6	229.5	12.1	224.9	206.7
213.3	24.4	229.6	20.0	225.6	19.4	225.2	15.7	222.1	12.3	219.4	-	216.1	213.3
216.5	22.9	224.9	18.5	220.5	17.9	220.5	14.1	217.2	-	215.0	-	211.6	216.5
223.1	20.7	215.0	16.2	212.7	15.4	212.1	11.2	208.3	-	206.5	-	203.6	223.1
229.7	18.5	205.0	13.8	205.0	12.9	203.7	-	200.6	-	198.0	-	195.5	229.7
232.9	-	-	12.6	201.2	11.7	199.5	-	196.8	-	193.8	-	191.4	232.9
236.2	-	-	11.5	197.3	-	196.2	-	192.9	-	189.6	-	187.4	236.2
242.8	-	-	-	189.2	-	189.6	-	185.9	-	183.0	-	180.4	242.8
246.1	-	-	-	185.2	-	186.3	-	182.4	-	179.7	-	176.9	246.1
255.9	-	-	-	-	-	176.4	-	172.0	-	169.8	-	166.4	255.9
262.5	-	-	-	-	-	169.8	-	166.4	-	163.9	-	160.6	262.5
269.0	-	-	-	-	-	-	-	160.9	-	158.0	-	154.7	269.0
278.9	-	-	-	-	-	-	-	152.1	-	149.7	-	146.2	278.9
282.2	-	-	-	-	-	-	-	-	-	147.3	-	143.7	282.2
295.3	-	-	-	-	-	-	-	-	-	137.8	-	133.4	295.3
308.4	-	-	-	-	-	-	-	-	-	-	-	124.6	308.4
315.0	-	-	-	-	-	-	-	-	-	-	-	120.2	315.0

	0 lb	275,600 lb	363,800 lb	452,000 lb	540,200 lb	628,400 lb	716,600 lb
--	------	------------	------------	------------	------------	------------	------------

Operation

LSL

 363,800 lb + 110,200 lb  36.1-68.9 ft  27.6 ft  32.2 ft/s  360°  ASME B30.5																
177.2 ft		196.9 ft			216.5 ft			236.2 ft			255.9 ft			265.8 ft		
LSL_2		LSL_2			LSL_1			LSL_2			LSL_1			LSL_2		
0 lb		0 lb-716.6 klb		0 lb-716.6 klb		0 lb-716.6 klb		0 lb-716.6 klb		0 lb-716.6 klb		0 lb-716.6 klb		0 lb-716.6 klb		
1,000 lb																
ft																ft
26.2	765.0	765.0	-	-	-	-	-	-	-	-	-	-	-	-	-	26.2
29.5	705.5	765.0	665.8	765.0	630.5	765.0	-	-	-	-	-	-	-	-	-	29.5
32.8	632.7	765.0	599.7	765.0	568.8	765.0	555.6	765.0	765.0	529.1	716.5	729.7	765.0	-	-	32.8
36.1	576.5	765.0	547.8	765.0	521.4	765.0	511.5	765.0	765.0	487.2	716.5	729.7	765.0	546.7	765.0	36.1
39.4	520.3	765.0	496.0	765.0	474.0	765.0	467.4	765.0	765.0	445.3	716.5	729.7	765.0	502.7	765.0	39.4
45.9	440.9	765.0	421.1	765.0	403.4	765.0	401.2	765.0	765.0	383.6	716.5	729.7	765.0	432.1	765.0	45.9
52.5	381.4	765.0	366.0	765.0	350.5	765.0	348.3	765.0	765.0	335.1	712.1	723.1	765.0	377.0	765.0	52.5
59.1	332.9	765.0	321.9	765.0	308.6	765.0	308.6	765.0	765.0	295.4	709.9	723.1	765.0	332.9	765.0	59.1
65.6	288.8	765.0	284.4	765.0	273.4	765.0	275.6	765.0	765.0	264.6	709.9	723.1	765.0	295.4	765.0	65.6
72.2	251.3	765.0	249.1	765.0	244.7	765.0	246.9	743.0	756.2	238.1	707.7	716.5	765.0	266.8	765.0	72.2
78.7	220.5	765.0	219.4	765.0	215.0	762.8	222.7	718.7	731.9	216.1	679.0	690.0	765.0	240.3	765.0	78.7
85.3	197.3	712.1	194.0	707.7	190.7	703.3	197.3	696.7	703.3	194.0	652.6	661.4	727.5	218.8	726.4	85.3
91.9	177.5	659.2	174.2	654.8	170.9	650.4	177.5	657.0	650.4	173.1	626.1	634.9	690.0	197.3	687.8	91.9
98.4	159.8	612.9	157.6	608.5	153.2	604.1	159.8	610.7	604.1	155.4	601.9	599.7	643.8	178.0	640.4	98.4
111.5	134.8	540.9	131.9	536.5	127.5	532.0	133.4	538.7	532.0	129.7	531.3	527.6	560.0	145.0	556.7	111.5
124.7	114.0	476.9	110.6	472.5	106.3	468.1	111.6	474.0	468.9	108.2	468.9	464.4	491.6	120.4	489.4	124.7
137.8	97.2	421.1	93.7	416.7	89.5	412.3	94.6	416.7	414.5	90.8	414.5	410.1	437.3	100.8	435.0	137.8
150.9	85.2	365.2	81.5	375.5	76.9	371.1	81.9	375.5	371.8	77.6	371.8	368.9	390.2	83.1	388.0	150.9
160.8	76.7	324.1	73.1	344.7	68.2	342.5	73.2	346.9	342.8	68.5	342.5	340.2	362.7	73.4	360.5	160.8
164.0	-	-	70.8	334.4	65.8	334.4	70.7	338.8	335.1	66.0	334.4	332.2	353.5	70.2	351.3	164.0
177.2	-	-	61.5	293.2	56.2	302.0	60.8	306.4	304.2	56.0	302.0	299.8	321.1	58.8	318.9	177.2
190.3	-	-	-	-	48.8	272.1	53.4	281.5	279.3	48.4	277.0	274.8	293.2	48.9	291.0	190.3
193.6	-	-	-	-	47.0	264.6	51.5	275.2	273.0	46.4	270.8	268.6	287.3	47.0	285.1	193.6
203.4	-	-	-	-	-	-	46.6	259.0	256.8	41.6	255.0	252.8	269.7	41.3	267.5	203.4
210.0	-	-	-	-	-	-	43.7	249.1	246.9	38.7	245.4	243.2	257.9	37.5	255.7	210.0
216.5	-	-	-	-	-	-	-	-	-	35.7	235.9	233.7	248.2	34.5	246.2	216.5
226.4	-	-	-	-	-	-	-	-	-	32.2	219.4	218.3	233.7	29.9	231.9	226.4
229.7	-	-	-	-	-	-	-	-	-	-	-	-	-	28.4	227.1	229.7
236.2	-	-	-	-	-	-	-	-	-	-	-	-	-	25.8	219.4	236.2

 0 lb
 143,300 lb
 275,600 lb
 363,800 lb
 452,000 lb
 540,200 lb
 628,400 lb
 716,600 lb

LSL_1, LSL_2:  **36.1 ft - 62.3 ft**

LSL_15:  **42.7 ft - 68.9 ft**

LSL_15:  **496,100 lb + 110,200 lb**

Operation

LSL

363,800 lb + 110,200 lb 36.1-68.9 ft 27.6 ft 32.2 ft/s 360° ASME B30.5																		
275.6 ft		285.5 ft			295.3 ft				305.1 ft			315.0 ft						
LSL_1		LSL_2	LSL_15			LSL_1		LSL_2	LSL_15		LSL_1	LSL_2		LSL_7	LSL_15			
0 lb		0 lb-716.6 klb			0 lb-716.6 klb				0 lb-716.6 klb			0 lb-716.6 klb						
1,000 lb																		
ft																		ft
36.1	465.2	597.5	661.4	765.0	522.5	765.0	445.3	551.2	608.5	765.0	-	-	-	-	-	-	-	36.1
39.4	429.9	597.5	661.4	765.0	480.6	765.0	412.3	551.2	608.5	765.0	460.8	760.6	394.6	476.2	533.5	586.4	749.6	39.4
45.9	372.6	597.5	661.4	765.0	414.5	765.0	357.1	546.7	606.3	765.0	396.8	760.6	343.9	471.8	529.1	586.4	749.6	45.9
52.5	326.3	595.2	659.2	765.0	361.6	765.0	313.1	546.7	604.1	765.0	346.1	760.6	302.0	467.4	529.1	586.4	749.6	52.5
59.1	288.8	582.0	643.8	765.0	319.7	765.0	277.8	533.5	588.6	765.0	306.4	760.6	266.8	458.6	529.1	586.4	749.6	59.1
65.6	257.9	575.4	639.3	765.0	284.4	765.0	246.9	520.3	575.4	765.0	273.4	760.6	240.3	449.7	529.1	582.0	749.6	65.6
72.2	233.7	571.0	637.1	765.0	255.7	765.0	222.7	511.5	566.6	765.0	244.7	760.6	217.2	440.9	529.1	573.2	749.6	72.2
78.7	211.6	557.8	623.9	765.0	231.5	765.0	202.8	500.4	555.6	765.0	220.5	760.6	196.2	432.1	529.1	571.0	740.8	78.7
85.3	192.9	537.9	599.7	725.3	211.1	723.1	185.2	485.0	537.9	722.0	201.2	717.6	178.6	423.3	529.1	571.0	706.6	85.3
91.9	175.3	518.1	575.4	685.6	190.7	681.2	169.8	465.2	518.1	679.0	181.9	674.6	164.2	407.9	515.9	568.8	672.4	91.9
98.4	157.6	498.2	553.4	638.2	173.1	634.9	155.4	447.5	498.2	632.7	166.4	628.3	151.0	394.6	509.3	546.7	627.2	98.4
111.5	131.2	457.1	506.3	554.5	141.1	552.3	129.0	412.3	457.1	550.1	137.2	545.6	126.0	365.2	474.7	499.7	544.5	111.5
124.7	109.4	418.9	458.6	487.2	116.0	485.0	107.1	377.0	416.7	483.9	111.8	480.6	104.9	335.8	448.3	449.7	478.4	124.7
137.8	92.4	383.6	410.1	432.8	96.3	430.6	89.7	341.7	377.0	429.9	91.3	427.7	87.5	306.4	405.7	396.8	425.5	137.8
150.9	79.1	351.3	367.4	385.8	78.7	383.6	76.2	313.8	344.7	381.4	73.6	379.2	73.9	281.5	363.0	354.2	377.0	150.9
164.0	67.5	321.1	330.0	349.1	65.8	346.9	64.4	287.3	313.8	346.1	60.6	343.9	61.9	257.9	325.5	316.7	341.7	164.0
177.2	57.3	293.2	297.6	316.7	54.3	314.5	54.2	262.4	284.4	313.8	49.0	311.6	51.6	235.9	293.2	284.4	309.4	177.2
190.3	49.5	266.8	272.6	288.8	44.3	286.6	46.3	240.3	256.5	284.4	39.0	282.2	43.7	217.5	268.2	259.4	280.0	190.3
203.4	42.5	241.4	248.4	265.3	36.5	263.1	39.2	219.4	230.8	260.9	31.1	258.7	36.5	199.2	246.2	237.4	257.9	203.4
216.5	36.4	218.3	224.9	244.0	29.5	241.8	32.8	199.5	209.4	240.3	24.0	237.7	30.2	181.9	227.1	218.3	237.4	216.5
229.7	31.7	199.9	202.1	224.9	23.4	222.7	27.9	183.4	189.6	222.7	17.9	219.4	25.1	166.4	210.2	201.7	218.3	229.7
242.8	27.3	181.1	184.1	209.9	18.2	208.0	23.4	168.7	170.5	206.5	12.3	203.9	20.4	151.8	195.1	187.0	202.4	242.8
246.1	26.2	176.4	180.8	206.1	16.9	204.3	22.4	164.8	165.9	202.5	10.9	200.1	19.4	148.8	191.8	183.5	198.4	246.1
249.3	-	-	-	-	15.7	200.6	21.4	160.9	161.3	198.4	9.5	196.2	18.4	145.9	188.5	180.0	195.1	249.3
252.6	-	-	-	-	14.3	197.3	20.4	157.1	156.7	195.1	-	192.9	17.3	142.9	185.2	176.6	191.8	252.6
255.9	-	-	-	-	-	-	19.4	153.2	152.1	191.8	-	189.6	16.3	140.0	181.9	173.1	188.5	255.9
262.5	-	-	-	-	-	-	17.6	145.5	147.7	185.2	-	183.0	14.7	133.7	176.0	167.2	181.9	262.5
269.0	-	-	-	-	-	-	-	-	-	-	-	176.4	13.1	127.5	170.1	161.3	175.3	269.0
278.9	-	-	-	-	-	-	-	-	-	-	-	-	10.8	119.0	162.0	153.2	166.4	278.9

0 lb
 143,300 lb
 275,600 lb
 363,800 lb
 452,000 lb
 540,200 lb
 628,400 lb
 716,600 lb

LSL_1, LSL_2, LSL_7: 36.1 ft – 62.3 ft

LSL_15: 42.7 ft – 68.9 ft

LSL_15: 496,100 lb + 110,200 lb

Operation

LSL

363,800 lb + 110,200 lb 36.1-68.9 ft 27.6 ft 32.2 ft/s 360° ASME B30.5																
324.8 ft 334.6 ft 344.5 ft																
LSL_7 LSL_15 LSL_1 LSL_2 LSL_7 LSL_11 LSL_15 LSL_7 LSL_9 LSL_11 LSL_15																
0 lb 0 lb - 716.6 klb 0 lb 0 lb - 716.6 klb 0 lb 0 lb - 716.6 klb																
ft	1,000 lb															ft
39.4	366.0	557.8	692.3	379.2	432.1	480.6	526.9	588.6	604.1	692.3	-	-	-	-	-	39.4
42.7	340.6	557.8	692.3	353.8	432.1	478.4	526.9	588.6	601.9	692.3	324.1	500.4	562.2	577.6	683.4	42.7
45.9	315.3	557.8	692.3	328.5	432.1	476.2	526.9	588.6	599.7	692.3	302.0	500.4	562.2	575.4	683.4	45.9
52.5	275.6	557.8	692.3	288.8	432.1	476.2	526.9	588.6	597.5	692.3	262.4	500.4	562.2	573.2	683.4	52.5
59.1	242.5	557.8	692.3	257.9	432.1	476.2	526.9	584.2	593.0	692.3	231.5	500.4	557.8	568.8	681.2	59.1
65.6	216.1	555.6	692.3	229.3	429.9	476.2	526.9	582.0	586.4	692.3	206.1	500.4	553.4	564.4	676.8	65.6
72.2	192.9	544.5	692.3	208.3	427.7	476.2	515.9	579.8	582.0	692.3	184.1	491.6	553.4	560.0	672.4	72.2
78.7	173.1	540.1	692.3	188.5	427.7	474.0	507.1	568.8	573.2	692.3	165.3	478.4	542.3	555.6	663.6	78.7
85.3	156.5	537.9	680.1	172.0	425.5	474.0	504.9	562.2	566.6	675.7	148.8	476.2	533.5	549.0	651.5	85.3
91.9	141.1	537.9	668.0	156.5	423.3	474.0	502.7	553.4	555.6	659.2	134.5	471.8	526.9	540.1	639.3	91.9
98.4	129.0	522.5	622.8	143.3	418.9	471.8	493.8	535.7	540.1	617.3	121.3	467.4	509.3	524.7	606.3	98.4
111.5	108.0	488.7	541.2	122.0	400.5	459.3	460.8	499.0	507.8	539.0	101.3	435.8	474.0	489.4	536.8	111.5
124.7	88.0	446.1	476.2	102.5	375.5	438.0	427.7	463.0	469.6	472.9	82.5	406.4	439.5	454.9	470.7	124.7
137.8	69.2	394.6	424.0	84.9	363.8	401.2	392.4	427.7	425.5	420.3	64.8	377.0	405.7	421.1	418.1	137.8
150.9	55.7	352.0	377.0	71.1	346.9	358.6	351.3	383.6	381.4	374.8	51.3	344.7	374.8	378.5	372.6	150.9
164.0	43.9	315.3	341.7	59.0	326.3	321.9	314.5	343.9	342.5	338.0	39.5	312.3	341.7	340.2	335.8	164.0
177.2	33.7	284.4	309.4	48.7	295.4	291.0	282.2	308.6	308.6	305.7	29.3	280.0	306.4	306.4	303.5	177.2
190.3	25.9	257.9	280.0	40.6	270.4	264.6	257.2	282.2	280.7	277.8	21.4	255.0	280.0	278.5	275.6	190.3
203.4	18.9	235.2	256.5	33.4	247.7	241.8	234.4	258.7	256.5	254.3	14.2	232.4	256.5	254.3	252.1	203.4
213.3	14.1	220.8	240.1	28.7	232.2	227.4	219.0	243.2	241.0	237.9	9.3	217.2	241.0	238.8	235.7	213.3
216.5	12.6	216.1	235.5	27.1	227.1	222.7	213.8	238.1	235.9	233.3	-	211.6	235.9	233.7	231.0	216.5
223.1	9.9	207.2	226.3	24.5	219.4	214.6	205.5	229.3	226.5	224.1	-	203.6	226.5	222.7	221.8	223.1
229.7	-	199.5	217.2	21.8	211.6	206.5	197.5	220.5	217.2	215.0	-	195.5	217.2	215.0	212.7	229.7
242.8	-	184.8	201.0	17.1	196.9	191.1	182.6	204.3	202.1	199.3	-	180.4	201.7	199.9	197.3	242.8
255.9	-	170.9	186.3	13.0	183.0	177.5	168.7	189.6	187.4	185.2	-	166.4	186.3	185.2	182.6	255.9
269.0	-	159.1	173.1	9.3	170.9	165.7	157.6	177.1	174.9	172.0	-	150.3	171.6	172.7	168.7	269.0
282.2	-	148.3	162.0	-	160.6	155.1	144.4	164.2	163.5	160.2	-	134.1	155.8	159.1	157.6	282.2
288.7	-	143.3	156.5	-	155.8	150.3	136.7	157.6	158.4	154.3	-	126.0	147.3	151.8	152.1	288.7
295.3	-	-	-	-	151.0	145.5	129.0	151.0	153.2	148.8	-	121.3	140.0	144.4	147.3	295.3
305.1	-	-	-	-	-	-	-	-	-	-	-	110.2	131.2	131.2	140.0	305.1

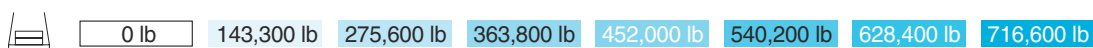

LSL_1 – LSL_7: 36.1 ft – 62.3 ft

LSL_9 – LSL_11: 36.1 ft – 68.9 ft

LSL_15: 42.7 ft – 68.9 ft

LSL_15: 496,100 lb + 110,200 lb

Operation

LSL

363,800 lb + 110,200 lb 36.1-68.9 ft 27.6 ft 32.2 ft/s 360° ASME B30.5													
354.3 ft 364.2 ft													
LSL_1 LSL_2 LSL_7 LSL_9 LSL_11 LSL_15 LSL_7 LSL_9 LSL_11 LSL_15													
0 lb 0 lb - 716.6 klb 0 lb 0 lb - 716.6 klb													
ft	1,000 lb											ft	
42.7	337.3	390.2	429.9	478.4	533.5	553.4	619.5	308.6	456.4	509.3	529.1	619.5	42.7
45.9	315.3	390.2	429.9	478.4	533.5	553.4	619.5	286.6	456.4	509.3	529.1	619.5	45.9
52.5	275.6	390.2	429.9	478.4	533.5	549.0	619.5	251.3	456.4	509.3	526.9	619.5	52.5
59.1	244.7	390.2	429.9	478.4	533.5	546.7	619.5	220.5	451.9	509.3	524.7	619.5	59.1
65.6	220.5	388.0	429.9	476.2	533.5	540.1	619.5	196.2	447.5	509.3	520.3	617.3	65.6
72.2	198.4	388.0	429.9	471.8	533.5	537.9	619.5	175.3	443.1	509.3	515.9	612.9	72.2
78.7	179.7	385.8	429.9	458.6	529.1	535.7	619.5	156.5	434.3	504.9	513.7	606.3	78.7
85.3	163.1	385.8	427.7	451.9	524.7	526.9	617.3	141.1	427.7	500.4	502.7	595.2	85.3
91.9	148.8	383.6	427.7	447.5	520.3	520.3	615.1	126.8	421.1	500.4	493.8	584.2	91.9
98.4	135.6	383.6	427.7	443.1	518.1	507.1	590.8	114.6	416.7	496.0	482.8	565.5	98.4
111.5	115.6	374.8	421.8	415.2	485.0	471.8	532.4	94.8	391.7	469.6	447.5	520.3	111.5
124.7	97.5	359.4	406.4	386.5	456.4	437.3	468.5	77.2	365.2	443.9	413.7	465.2	124.7
137.8	81.4	348.3	399.0	357.1	421.1	403.4	415.9	61.9	337.3	418.9	381.4	413.0	137.8
150.9	67.5	332.9	356.4	330.7	378.5	371.1	370.4	48.3	310.9	376.3	352.0	366.0	150.9
164.0	55.4	316.7	318.9	305.0	339.5	338.0	335.1	36.4	285.9	337.3	323.3	330.7	164.0
177.2	45.0	293.2	286.6	280.0	304.2	304.2	303.5	26.2	262.4	302.0	295.4	299.1	177.2
190.3	36.9	268.2	261.6	253.5	277.8	277.8	275.6	18.2	240.3	275.6	271.9	271.2	190.3
203.4	29.6	245.4	239.2	230.4	254.3	253.5	252.1	10.9	219.7	251.3	249.6	249.1	203.4
206.7	28.0	240.3	234.2	225.4	249.1	248.0	246.2	9.3	215.0	245.8	244.3	243.6	206.7
216.5	23.1	224.9	219.4	211.6	233.7	231.5	230.0	-	200.6	229.3	227.1	227.1	216.5
229.7	17.9	208.7	202.6	194.7	214.4	213.8	212.7	-	182.2	212.4	208.7	210.5	229.7
242.8	13.0	193.6	187.4	177.5	198.8	197.7	196.6	-	164.6	196.6	190.7	194.4	242.8
252.6	9.7	183.0	177.5	164.2	187.8	186.7	185.2	-	151.9	185.6	177.5	183.0	252.6
255.9	-	179.7	174.2	159.8	184.1	183.0	181.9	-	147.7	181.9	173.1	179.7	255.9
269.0	-	167.9	162.4	142.9	171.6	169.0	168.7	-	132.3	169.4	156.2	166.4	269.0
282.2	-	156.9	151.4	127.5	160.2	153.6	156.9	-	117.4	158.0	141.5	154.7	282.2
295.3	-	146.6	141.1	113.5	149.9	136.7	146.2	-	103.2	147.7	126.8	143.3	295.3
308.4	-	137.8	133.2	99.3	141.1	123.2	136.7	-	90.4	138.2	111.7	132.3	308.4
311.7	-	135.6	131.2	95.7	138.9	120.2	134.5	-	87.5	135.8	109.7	130.1	311.7
321.5	-	-	-	-	-	-	-	-	78.0	130.1	100.5	123.5	321.5

0 lb 143,300 lb 275,600 lb 363,800 lb 452,000 lb 540,200 lb 628,400 lb 716,600 lb

LSL_1 – LSL_7: 36.1 ft – 62.3 ft



























LSL_9 – LSL_11: 36.1 ft – 68.9 ft

LSL_15: 42.7 ft – 68.9 ft

LSL_15: 496,100 lb + 110,200 lb

Operation

LSL

 363,800 lb +  110,200 lb  36.1-68.9 ft  27.6 ft  32.2 ft/s 360° ASME B30.5															
                															
 0 lb  0 lb - 716.6 klb  0 lb  0 lb - 716.6 klb 															
ft	1,000 lb														ft
42.7	321.9	357.1	388.0	407.9	429.9	482.8	507.1	595.2	-	-	-	-	-	-	42.7
45.9	302.0	357.1	385.8	407.9	429.9	482.8	507.1	595.2	280.0	385.8	405.7	460.8	480.6	544.5	45.9
52.5	264.6	357.1	385.8	407.9	429.9	482.8	504.9	595.2	246.9	385.8	405.7	460.8	480.6	544.5	52.5
59.1	235.9	354.9	385.8	407.9	429.9	482.8	502.7	595.2	218.3	385.8	405.7	460.8	480.6	544.5	59.1
65.6	210.5	350.9	385.8	407.9	429.9	482.8	493.8	595.2	194.0	385.8	403.4	460.8	471.8	544.5	65.6
72.2	189.6	352.7	385.8	407.9	429.9	482.8	491.6	595.2	173.1	385.8	403.4	458.6	465.2	544.5	72.2
78.7	170.9	352.7	385.8	405.7	427.7	478.4	489.4	593.0	155.4	383.6	403.4	456.4	463.0	544.5	78.7
85.3	155.4	350.5	385.8	405.7	423.3	478.4	480.6	583.1	140.0	383.6	401.2	456.4	456.4	544.5	85.3
91.9	141.1	350.5	383.6	403.4	423.3	471.8	469.6	573.2	126.8	381.4	401.2	451.9	445.3	544.5	91.9
98.4	129.0	350.5	383.6	394.6	421.1	465.2	458.6	556.7	114.6	379.2	399.0	449.7	434.3	531.3	98.4
111.5	109.4	343.2	380.7	379.9	406.4	439.5	426.2	514.8	95.2	367.4	387.3	429.9	403.4	499.3	111.5
124.7	92.2	331.4	374.1	366.0	391.7	413.7	393.9	461.9	78.3	354.2	372.6	410.8	372.6	455.3	124.7
137.8	77.2	321.9	368.2	357.1	377.0	390.2	361.6	410.8	63.7	343.9	359.4	392.4	341.7	407.1	137.8
150.9	63.3	310.1	343.9	338.0	341.7	363.8	333.6	363.8	51.2	332.9	334.4	364.5	313.8	361.6	150.9
164.0	51.2	296.9	316.7	314.5	307.9	335.8	306.4	328.5	39.8	312.3	305.7	333.6	287.3	326.3	164.0
177.2	40.8	286.6	284.4	282.2	275.6	302.0	280.0	296.9	29.5	280.0	273.4	299.8	262.4	294.7	177.2
190.3	32.7	263.1	259.4	257.2	250.6	274.1	256.5	269.0	21.5	255.0	248.4	271.9	238.8	266.8	190.3
203.4	25.4	241.0	237.0	234.4	227.1	249.6	234.8	246.9	14.2	232.4	226.4	247.7	217.2	242.5	203.4
213.3	20.6	225.6	222.1	219.0	213.0	233.7	219.9	231.1	9.3	217.2	211.2	232.2	203.1	227.1	213.3
216.5	19.0	220.5	217.2	213.8	208.3	229.3	215.0	226.3	-	211.6	206.1	227.1	198.4	222.7	216.5
229.7	13.7	204.3	199.9	196.9	192.2	211.6	196.6	207.2	-	195.5	190.0	209.4	180.8	205.0	229.7
239.5	9.7	192.9	188.3	185.2	180.6	199.2	183.4	195.7	-	183.9	178.4	196.9	168.1	192.9	239.5
242.8	-	189.4	184.8	181.9	177.1	195.5	179.3	191.8	-	180.4	174.9	193.3	164.2	188.9	242.8
255.9	-	175.3	170.9	168.7	163.1	180.8	163.1	177.5	-	166.4	160.9	178.6	148.8	174.2	255.9
269.0	-	163.5	159.1	156.9	151.4	168.3	147.7	164.2	-	154.7	149.2	166.1	134.1	160.9	269.0
282.2	-	152.9	148.4	145.9	140.4	156.5	132.6	152.5	-	143.7	137.8	154.3	120.2	149.9	282.2
295.3	-	143.3	138.9	135.6	130.1	145.5	119.0	141.3	-	133.4	126.8	143.3	107.1	138.9	295.3
308.4	-	134.5	130.1	126.8	120.6	136.7	106.1	131.2	-	124.6	117.2	134.5	94.2	127.9	308.4
321.5	-	126.1	121.7	119.0	111.8	128.1	93.1	122.4	-	117.3	108.4	126.0	81.6	118.3	321.5
331.4	-	120.2	115.7	113.5	105.8	122.4	83.3	115.7	-	111.3	102.3	120.0	73.6	109.5	331.4
334.6	-	-	-	-	-	-	-	-	-	109.3	100.3	117.9	71.0	105.5	334.6
337.9	-	-	-	-	-	-	-	-	-	107.6	98.3	115.7	68.1	101.4	337.9



LSL_1 – LSL_7:  36.1 ft – 62.3 ft

LSL_9 – LSL_11:  36.1 ft – 68.9 ft

LSL_15:  42.7 ft – 68.9 ft

LSL_15:  496,100 lb +  110,200 lb

Operation

LSL

363,800 lb + 110,200 lb 36.1-68.9 ft 27.6 ft 32.2 ft/s 360° ASME B30.5																	
393.7 ft 403.5 ft																	
LSL_1 LSL_2 LSL_5 LSL_7 LSL_9 LSL_11 LSL_13 LSL_15 LSL_5 LSL_7 LSL_9 LSL_11 LSL_13 LSL_15																	
0 lb 0 lb - 716.6 klb 0 lb 0 lb - 716.6 klb																	
ft	1,000 lb															ft	
45.9	291.0	304.2	337.3	352.7	388.0	438.7	454.2	471.8	533.5	271.2	337.3	366.0	418.9	434.3	449.7	507.1	45.9
52.5	255.7	302.0	335.1	352.7	388.0	438.7	454.2	471.8	533.5	238.1	337.3	366.0	418.9	434.3	449.7	507.1	52.5
59.1	227.1	302.0	335.1	352.7	388.0	438.7	454.2	471.8	533.5	210.5	337.3	366.0	418.9	434.3	449.7	507.1	59.1
65.6	203.9	302.0	335.1	352.7	388.0	438.7	454.2	469.6	533.5	187.4	335.1	366.0	418.9	434.3	449.7	507.1	65.6
72.2	183.0	299.8	332.9	352.7	388.0	436.5	451.9	467.4	533.5	167.6	335.1	366.0	416.7	432.1	447.5	507.1	72.2
78.7	165.3	297.6	332.9	352.7	385.8	434.3	449.7	465.2	533.5	149.9	335.1	363.8	416.7	429.9	443.1	504.9	78.7
85.3	149.9	297.6	332.9	350.5	383.6	434.3	449.7	465.2	524.7	134.5	332.9	361.6	414.5	429.9	443.1	494.9	85.3
91.9	135.6	295.4	332.9	348.3	381.4	432.1	445.3	456.4	515.9	121.3	330.7	361.6	412.3	425.5	436.5	487.2	91.9
98.4	124.6	295.4	330.7	346.1	379.2	429.9	443.1	449.7	502.7	110.0	330.7	359.4	410.1	423.3	432.1	475.1	98.4
111.5	105.0	291.0	327.8	338.8	371.1	414.5	427.0	425.5	474.0	91.1	326.3	352.7	399.0	410.1	410.1	447.5	111.5
124.7	88.0	285.9	324.8	326.3	360.1	399.0	410.8	395.4	442.0	74.5	315.3	342.5	382.9	396.1	383.6	415.6	124.7
137.8	73.4	280.0	321.9	317.5	346.1	383.6	394.6	366.0	403.4	60.4	306.4	330.7	368.2	381.4	350.5	385.1	137.8
150.9	61.5	272.6	310.9	306.4	330.0	361.6	363.8	336.6	359.4	48.6	299.1	320.4	351.3	357.9	322.6	357.1	150.9
164.0	50.3	261.6	299.8	293.2	305.7	332.9	331.4	305.7	324.1	37.6	288.1	300.6	327.8	329.2	293.9	324.8	164.0
177.2	39.9	255.7	282.2	280.0	273.4	297.6	297.6	277.8	292.5	27.3	277.8	271.2	295.4	295.4	264.6	294.7	177.2
190.3	31.7	247.7	257.2	255.0	248.4	271.2	271.2	251.3	264.6	19.3	252.8	244.7	269.0	269.0	238.1	266.8	190.3
203.4	24.3	236.6	234.8	232.4	225.6	246.2	244.7	226.0	240.3	11.8	230.0	223.4	243.8	244.7	213.8	242.5	203.4
206.7	22.7	232.6	229.8	227.3	220.5	240.3	239.8	220.5	234.8	10.1	224.9	218.3	238.5	239.2	208.3	237.0	206.7
216.5	17.9	220.5	215.0	211.6	205.0	224.9	224.9	203.9	220.5	-	210.5	202.8	222.7	222.7	191.8	222.3	216.5
229.7	12.4	203.6	198.0	195.5	188.1	208.0	207.2	183.4	202.8	-	193.6	185.9	205.8	205.0	172.0	203.9	229.7
236.2	9.7	195.1	189.6	187.4	179.7	199.5	198.4	173.1	194.7	-	185.2	177.5	197.3	196.2	162.0	195.8	236.2
242.8	-	188.1	182.6	180.4	172.7	192.2	191.1	164.6	186.7	-	178.2	170.5	190.0	188.9	153.6	187.8	242.8
255.9	-	174.2	168.7	166.4	158.7	177.5	176.4	147.7	172.0	-	164.2	156.5	175.3	174.2	136.7	173.1	255.9
269.0	-	162.4	156.9	154.7	147.7	165.0	163.9	133.7	158.7	-	152.5	144.8	162.8	161.7	123.5	159.8	269.0
282.2	-	151.8	146.2	143.7	136.3	153.2	152.1	121.6	147.7	-	141.5	133.4	151.0	149.7	111.3	143.7	282.2
295.3	-	142.2	136.7	133.4	124.6	142.2	141.1	111.3	136.7	-	131.2	122.4	140.0	138.9	100.8	127.5	295.3
308.4	-	133.4	127.9	124.6	115.0	133.4	132.3	104.4	125.7	-	122.9	112.7	131.2	129.3	93.0	111.3	308.4
321.5	-	124.9	119.0	116.6	106.0	124.9	123.8	98.9	111.1	-	115.1	103.5	122.4	120.5	86.5	96.3	321.5
334.6	-	116.8	112.4	109.6	97.4	116.8	115.7	94.8	96.6	-	107.1	94.8	113.5	112.4	81.4	81.7	334.6
347.8	-	110.2	105.6	102.5	90.2	109.6	108.2	93.3	82.0	-	99.6	87.5	106.3	105.2	79.1	67.9	347.8
354.3	-	-	-	-	-	-	-	-	-	-	95.9	83.8	102.7	101.6	78.0	61.1	354.3

0 lb | 143,300 lb | 275,600 lb | 363,800 lb | 452,000 lb | 540,200 lb | 628,400 lb | 716,600 lb

LSL_1 – LSL_7: 36.1 ft – 62.3 ft





LSL_9 – LSL_13: 36.1 ft – 68.9 ft

LSL_15: 42.7 ft – 68.9 ft

LSL_15: 496,100 lb + 110,200 lb

Operation

LSL

 363,800 lb +  110,200 lb  36.1-68.9 ft  27.6 ft  32.2 ft/s 360° ASME B30.5																	
413.4 ft										423.2 ft							
LSL_1		LSL_2		LSL_5		LSL_7		LSL_9		LSL_11		LSL_13		LSL_15		LSL_15	
0 lb		0 lb - 716.6 klb										0 lb		0 lb - 716.6 klb			
ft	1,000 lb																ft
45.9	255.7	262.4	293.2	321.9	343.9	394.6	412.3	429.9	485.0	-	-	-	-	-	-	-	45.9
49.2	251.3	261.2	292.1	321.9	343.9	394.6	412.3	429.9	485.0	240.3	302.0	326.3	377.0	392.4	410.1	460.8	49.2
52.5	246.9	260.1	291.0	321.9	343.9	394.6	412.3	429.9	485.0	224.9	302.0	326.3	377.0	392.4	410.1	460.8	52.5
59.1	220.5	260.1	291.0	321.9	343.9	392.4	412.3	429.9	485.0	199.5	302.0	324.1	374.8	392.4	410.1	460.8	59.1
65.6	197.3	260.1	291.0	319.7	343.9	392.4	412.3	429.9	485.0	177.5	299.8	324.1	374.8	392.4	410.1	460.8	65.6
72.2	177.5	257.9	291.0	319.7	343.9	390.2	412.3	427.7	485.0	157.6	299.8	324.1	372.6	392.4	407.9	460.8	72.2
78.7	159.8	255.7	288.8	319.7	343.9	388.0	410.1	427.7	485.0	141.1	299.8	324.1	370.4	390.2	407.9	456.4	78.7
85.3	145.5	253.5	286.6	317.5	341.7	385.8	407.9	423.3	478.4	126.8	297.6	321.9	370.4	388.0	403.4	449.7	85.3
91.9	132.3	251.3	286.6	317.5	339.5	385.8	407.9	418.9	474.0	113.5	297.6	319.7	368.2	388.0	403.4	445.3	91.9
98.4	120.2	251.3	286.6	315.3	337.3	381.4	403.4	416.7	464.1	102.7	295.4	319.7	366.0	383.6	399.0	434.3	98.4
111.5	101.5	247.7	283.7	312.3	334.4	374.1	393.9	400.5	439.8	84.1	293.9	315.3	360.1	377.0	387.3	409.0	111.5
124.7	85.1	244.0	280.0	306.4	324.8	363.8	378.5	382.1	411.2	67.8	289.5	307.9	350.5	363.0	374.8	381.4	124.7
137.8	71.0	238.1	275.6	297.6	313.1	350.5	363.8	361.6	382.1	54.0	282.2	297.6	337.3	348.3	357.1	354.2	137.8
150.9	59.8	233.7	271.2	288.8	304.2	336.6	343.2	336.6	352.7	43.1	274.8	286.6	323.3	329.2	335.1	326.3	150.9
164.0	49.0	227.8	262.4	280.7	290.3	318.9	321.1	314.5	321.9	33.2	268.2	276.3	309.4	311.6	313.8	302.8	164.0
177.2	38.6	220.5	257.9	273.4	271.2	295.4	293.2	291.0	292.5	24.3	262.4	264.6	293.2	291.0	288.8	280.0	177.2
190.3	30.4	213.8	247.7	249.9	244.7	267.5	266.8	264.6	264.6	16.2	246.2	241.0	265.0	262.4	262.4	257.9	190.3
200.1	24.6	209.1	239.8	233.0	226.7	248.4	248.0	246.0	244.7	10.4	231.5	224.5	246.2	246.0	243.8	241.4	200.1
203.4	23.0	207.6	234.8	227.8	221.9	243.2	242.5	240.7	239.6	-	226.6	219.7	241.0	240.7	238.5	235.9	203.4
216.5	16.5	201.7	215.0	209.4	202.8	222.7	220.5	219.4	220.1	-	207.2	200.6	220.5	219.4	217.2	215.3	216.5
229.7	11.1	196.2	198.0	192.5	185.9	205.0	203.6	198.8	201.7	-	190.3	183.0	202.1	201.0	199.5	196.2	229.7
232.9	9.7	195.1	193.8	188.3	181.7	200.6	199.3	193.6	197.7	-	186.1	178.6	197.5	196.4	195.1	191.6	232.9
242.8	-	187.0	182.6	177.1	170.1	188.5	187.4	178.9	185.6	-	174.9	166.4	185.6	184.5	181.9	177.8	242.8
255.9	-	173.1	168.7	163.1	155.4	173.1	172.0	159.8	170.9	-	160.9	151.0	170.9	169.8	164.2	160.2	255.9
269.0	-	161.3	156.9	151.4	142.9	160.6	159.5	143.7	157.6	-	149.2	138.9	155.4	155.1	146.6	143.3	269.0
282.2	-	150.3	145.9	140.4	130.8	149.0	147.7	127.9	145.5	-	138.0	126.8	141.1	141.1	130.8	127.9	282.2
295.3	-	140.0	135.6	130.1	119.0	138.9	137.8	115.7	129.0	-	127.9	115.7	127.9	127.9	116.8	112.8	295.3
308.4	-	131.2	126.8	120.6	109.6	127.1	127.5	106.3	113.5	-	117.6	106.3	116.8	116.8	105.8	98.1	308.4
321.5	-	123.1	119.0	111.6	100.6	116.8	117.8	98.4	99.3	-	108.2	97.3	106.6	106.9	96.6	84.0	321.5
334.6	-	115.7	111.3	103.2	91.9	107.8	108.7	91.9	85.2	-	99.9	88.6	97.2	98.1	89.1	70.3	334.6
347.8	-	106.4	104.7	95.5	84.2	100.3	101.5	88.8	71.4	-	92.2	81.0	89.4	90.5	84.8	57.1	347.8
360.9	-	94.1	95.4	88.5	77.3	93.5	94.9	86.9	58.6	-	85.1	73.9	82.4	83.4	81.6	44.6	360.9
364.2	-	91.1	92.4	86.9	75.6	91.9	93.5	86.6	55.6	-	83.5	72.3	80.8	81.8	81.5	41.6	364.2
374.0	-	-	-	-	-	-	-	-	-	-	78.7	67.5	76.1	77.6	81.1	32.8	374.0

0 lb
143,300 lb
275,600 lb
363,800 lb
452,000 lb
540,200 lb
628,400 lb
716,600 lb

LSL_1 – LSL_7:  36.1 ft – 62.3 ft

LSL_9 – LSL_13:  36.1 ft – 68.9 ft

LSL_15:  42.7 ft – 68.9 ft

LSL_15:  496,100 lb +  110,200 lb

Operation

LSL

363,800 lb + 110,200 lb 36.1-68.9 ft 27.6 ft 32.2 ft/s 360° ASME B30.5																	
433.1 ft 442.9 ft																	
LSL_1 LSL_2 LSL_5 LSL_7 LSL_9 LSL_11 LSL_13 LSL_15 LSL_5 LSL_7 LSL_9 LSL_11 LSL_13 LSL_15																	
0 lb 0 lb - 716.6 klb 0 lb 0 lb - 716.6 klb																	
ft	1,000 lb															ft	
49.2	217.2	222.7	253.5	280.0	304.2	343.9	359.4	394.6	418.9	231.5	266.8	286.6	326.3	341.7	374.8	399.0	49.2
52.5	216.1	222.7	253.5	280.0	304.2	343.9	359.4	394.6	418.9	218.3	266.8	286.6	326.3	341.7	374.8	399.0	52.5
59.1	212.7	220.5	253.5	280.0	302.0	343.9	359.4	392.4	418.9	191.8	266.8	286.6	326.3	341.7	374.8	399.0	59.1
65.6	190.7	220.5	251.3	280.0	302.0	343.9	359.4	390.2	418.9	170.9	266.8	286.6	326.3	341.7	374.8	399.0	65.6
72.2	172.0	219.4	251.3	280.0	302.0	343.9	357.1	390.2	418.9	152.1	264.6	284.4	326.3	339.5	372.6	399.0	72.2
78.7	154.3	217.2	249.1	277.8	302.0	341.7	357.1	388.0	418.9	135.6	264.6	284.4	324.1	339.5	370.4	399.0	78.7
85.3	140.0	216.1	249.1	277.8	299.8	341.7	354.9	385.8	418.9	121.3	264.6	284.4	324.1	337.3	368.2	399.0	85.3
91.9	127.9	213.8	246.9	275.6	299.8	339.5	354.9	385.8	418.9	109.3	262.4	282.2	324.1	337.3	368.2	399.0	91.9
98.4	115.7	211.6	246.9	275.6	297.6	337.3	350.5	383.6	416.7	98.3	260.1	282.2	321.9	335.1	366.0	395.7	98.4
111.5	97.5	209.4	245.4	272.6	294.7	330.0	343.2	377.0	410.1	80.1	258.7	279.3	317.5	330.7	362.3	390.2	111.5
124.7	81.4	205.8	242.5	267.5	289.5	318.2	327.8	364.5	396.8	64.2	255.0	274.8	308.6	318.2	349.8	379.2	124.7
137.8	67.5	200.6	238.1	260.1	282.2	308.6	317.5	343.9	373.3	50.5	249.1	269.0	295.4	306.4	330.7	359.4	137.8
150.9	56.6	195.8	233.7	254.3	274.8	297.6	306.4	321.9	343.9	39.8	243.2	261.6	286.6	295.4	310.1	337.3	150.9
164.0	46.8	191.8	229.3	246.9	268.2	285.9	293.2	298.4	316.0	30.1	238.1	255.0	277.0	285.1	288.1	309.4	164.0
177.2	38.1	187.4	224.9	242.5	262.4	277.8	284.4	277.8	288.1	21.6	233.7	249.1	271.2	277.8	264.6	282.2	177.2
190.3	30.1	181.1	218.3	233.7	244.7	261.6	265.0	257.2	260.1	13.8	229.3	240.3	260.6	264.6	244.3	257.9	190.3
196.9	26.0	178.6	216.1	231.5	233.7	253.5	253.5	246.9	250.0	9.9	227.1	229.3	251.3	251.3	233.7	246.2	196.9
203.4	22.7	174.2	211.0	224.9	223.8	243.2	242.5	235.2	238.5	-	219.7	220.1	241.0	240.7	222.7	234.4	203.4
216.5	16.1	169.8	207.2	207.2	203.9	222.7	220.5	211.6	217.5	-	205.0	201.7	220.5	219.4	200.6	213.1	216.5
229.7	10.6	164.6	194.0	190.3	187.0	204.3	203.6	190.3	198.4	-	188.9	184.8	202.1	201.7	180.0	194.0	229.7
232.9	9.3	162.8	190.7	186.1	182.8	199.7	199.3	185.0	194.2	-	184.8	180.6	197.5	197.3	175.1	189.8	232.9
242.8	-	158.7	180.4	174.9	171.6	187.8	187.4	170.1	181.5	-	173.8	169.4	185.6	185.2	161.7	177.1	242.8
255.9	-	154.3	166.4	160.9	157.6	173.1	172.0	151.0	165.7	-	159.8	155.4	170.9	169.8	143.3	160.9	255.9
269.0	-	148.8	154.7	149.2	145.1	160.6	159.5	135.1	151.0	-	148.1	142.2	158.4	157.3	126.4	146.6	269.0
282.2	-	141.5	143.7	138.5	134.0	148.8	148.1	120.2	139.1	-	136.3	130.1	146.6	145.9	112.4	134.8	282.2
295.3	-	131.2	133.4	129.0	123.5	137.8	137.8	106.9	127.9	-	125.7	119.0	135.6	134.5	99.0	123.5	295.3
308.4	-	120.9	124.6	119.4	113.6	128.2	127.5	95.9	116.8	-	115.4	109.9	126.0	124.9	87.8	112.4	308.4
321.5	-	111.1	117.3	110.2	104.3	119.0	118.2	86.1	107.6	-	106.2	101.0	116.5	115.6	77.8	102.1	321.5
334.6	-	101.6	109.3	101.4	95.5	110.2	110.0	77.6	98.5	-	98.1	92.4	106.9	106.5	69.0	92.4	334.6
347.8	-	91.3	102.3	93.6	87.8	102.0	101.8	71.7	89.9	-	90.3	84.4	98.7	98.1	62.2	83.8	347.8
360.9	-	81.1	92.4	86.3	80.6	94.4	94.1	67.1	82.5	-	82.9	77.3	90.8	90.2	57.2	76.3	360.9
374.0	-	71.2	79.8	79.6	73.9	87.3	87.1	63.7	75.3	-	76.3	70.5	83.8	83.3	53.1	69.4	374.0
380.6	-	65.9	72.5	76.5	70.8	84.4	84.0	63.1	71.9	-	73.3	67.5	80.7	80.2	52.2	66.5	380.6
387.1	-	-	-	-	-	-	-	-	-	-	70.3	64.6	77.6	77.2	51.2	63.7	387.1
390.4	-	-	-	-	-	-	-	-	-	-	68.8	63.1	76.1	75.6	50.7	62.6	390.4

0 lb
 143,300 lb
 275,600 lb
 363,800 lb
 452,000 lb
 540,200 lb
 628,400 lb
 716,600 lb

LSL_1 – LSL_7: 36.1 ft – 62.3 ft

LSL_9 – LSL_13: 36.1 ft – 68.9 ft

LSL_15: 42.7 ft – 68.9 ft

LSL_15: 496,100 lb + 110,200 lb

Operation

LSL

363,800 lb + 110,200 lb 36.1-68.9 ft 27.6 ft 32.2 ft/s 360° ASME B30.5																	
472.4 ft 482.3 ft																	
LSL_1 LSL_2 LSL_5 LSL_7 LSL_9 LSL_11 LSL_13 LSL_15 LSL_5 LSL_7 LSL_9 LSL_11 LSL_13 LSL_15																	
0 lb 0 lb - 716.6 klb 0 lb 0 lb - 716.6 klb																	
ft	1,000 lb															ft	
52.5	160.9	166.4	189.6	224.9	233.7	277.8	293.2	313.1	343.9	198.4	213.8	222.7	264.6	277.8	297.6	326.3	52.5
59.1	159.8	165.3	188.5	224.9	233.7	275.6	293.2	313.1	343.9	174.2	212.7	220.5	262.4	277.8	297.6	326.3	59.1
65.6	158.7	163.1	187.4	222.7	231.5	275.6	293.2	310.9	343.9	154.3	211.6	220.5	262.4	277.8	297.6	326.3	65.6
72.2	156.5	162.0	186.3	222.7	231.5	275.6	291.0	310.9	343.9	136.7	211.6	220.5	262.4	277.8	297.6	326.3	72.2
78.7	144.4	159.8	185.2	222.7	231.5	273.4	291.0	308.6	343.9	121.3	210.5	220.5	262.4	275.6	297.6	326.3	78.7
85.3	130.1	157.6	183.0	222.7	231.5	273.4	288.8	308.6	341.7	108.0	210.5	219.4	260.1	275.6	295.4	324.1	85.3
91.9	117.9	156.5	181.9	220.5	229.3	273.4	286.6	306.4	339.5	96.1	210.5	218.3	260.1	273.4	293.2	321.9	91.9
98.4	107.8	154.3	179.7	220.5	227.1	273.4	286.6	304.2	338.4	85.5	209.4	217.2	260.1	273.4	291.0	320.8	98.4
111.5	90.0	150.6	177.1	218.3	224.1	269.0	280.7	298.4	335.1	68.0	207.2	214.2	257.2	269.0	286.6	317.5	111.5
124.7	74.4	147.3	174.9	215.7	221.2	264.6	269.7	289.5	328.5	52.8	205.0	211.6	252.8	263.1	277.8	312.0	124.7
137.8	60.8	144.4	172.0	212.7	218.3	260.1	262.4	280.0	317.5	39.7	202.8	209.4	246.9	255.7	269.0	302.8	137.8
150.9	50.4	140.7	168.3	208.3	210.9	254.3	252.8	269.7	304.2	29.2	198.4	205.0	241.0	246.2	259.4	291.0	150.9
164.0	40.9	136.7	164.6	203.9	203.2	248.4	242.5	257.9	285.1	19.9	194.4	198.4	235.9	238.1	246.9	276.3	164.0
177.2	32.4	132.3	160.9	199.5	197.3	242.5	233.7	249.1	265.3	11.7	190.7	194.0	231.5	231.5	240.3	257.9	177.2
180.4	30.7	131.4	160.0	198.4	196.2	240.3	231.5	244.7	260.1	9.9	189.8	191.3	230.0	228.9	236.3	252.4	180.4
190.3	25.5	128.6	157.3	195.7	190.3	235.9	224.9	238.1	242.5	-	187.0	186.7	225.6	223.4	229.3	235.9	190.3
203.4	19.1	124.9	153.2	190.0	184.1	226.0	216.8	226.3	222.7	-	183.4	180.4	216.8	215.7	219.0	216.8	203.4
216.5	13.2	121.3	149.9	186.3	177.5	210.5	209.4	211.6	203.6	-	179.7	175.3	205.0	206.1	207.2	198.4	216.5
226.4	8.8	118.5	145.5	178.0	173.6	198.4	198.4	199.0	189.8	-	172.5	171.4	193.5	194.6	194.6	185.2	226.4
229.7	-	117.6	144.8	175.3	172.3	194.4	194.7	194.7	185.2	-	170.1	170.1	189.6	190.7	190.3	180.8	229.7
242.8	-	113.9	140.7	163.9	163.9	178.9	180.0	178.6	169.0	-	159.5	160.9	174.9	175.6	174.5	164.6	242.8
255.9	-	110.2	136.7	152.1	152.1	164.2	165.3	163.1	153.6	-	147.7	147.7	160.9	160.9	159.8	149.5	255.9
269.0	-	106.6	133.7	139.8	139.8	151.9	152.1	150.5	138.9	-	136.0	136.0	147.0	147.7	146.6	135.6	269.0
282.2	-	103.0	128.6	129.0	129.0	140.0	140.0	138.9	127.1	-	124.2	124.6	135.6	135.6	134.5	123.1	282.2
295.3	-	99.0	125.7	117.9	117.9	129.0	129.0	127.9	116.2	-	112.4	113.5	124.6	124.6	123.5	111.7	295.3
308.4	-	92.5	115.7	105.3	108.2	117.9	118.7	117.6	106.0	-	100.7	104.4	114.9	114.9	113.6	101.6	308.4
321.5	-	84.8	104.8	92.7	99.2	108.1	108.9	107.7	96.6	-	88.8	95.7	105.4	105.3	103.4	92.4	321.5
334.6	-	77.2	94.8	80.2	90.8	99.4	99.6	98.3	87.7	-	76.9	87.5	96.1	95.9	93.0	83.6	334.6
347.8	-	70.0	83.9	69.2	82.2	91.0	91.0	89.8	79.4	-	66.5	79.9	87.7	87.5	83.5	75.2	347.8
360.9	-	62.9	72.8	59.4	71.9	83.2	82.4	82.0	71.5	-	56.9	71.0	79.9	79.7	74.6	67.5	360.9
374.0	-	55.1	62.8	50.7	60.6	75.8	73.4	74.5	64.3	-	48.1	60.8	72.5	72.3	66.4	60.3	374.0
387.1	-	47.5	51.4	43.4	51.6	69.3	65.3	67.9	57.5	-	40.6	51.6	65.9	64.1	59.3	53.6	387.1
400.3	-	39.8	40.5	36.7	44.6	63.4	58.2	62.1	51.4	-	33.8	43.5	59.8	56.2	52.8	47.4	400.3
413.4	-	32.4	29.5	31.3	38.6	58.0	52.0	56.7	45.9	-	27.8	37.0	54.2	49.2	47.0	41.7	413.4
416.7	-	30.4	26.7	30.2	37.5	56.7	50.7	55.3	44.5	-	26.5	35.6	53.0	47.8	45.7	40.3	416.7
423.2	-	-	-	-	-	-	-	-	-	-	24.0	32.8	50.5	45.0	43.4	37.7	423.2

0 lb | 143,300 lb | 275,600 lb | 363,800 lb | 452,000 lb | 540,200 lb | 628,400 lb | 716,600 lb

LSL_1 – LSL_7: 36.1 ft – 62.3 ft

LSL_9 – LSL_13: 36.1 ft – 68.9 ft

LSL_15: 42.7 ft – 68.9 ft

LSL_15: 496,100 lb + 110,200 lb

Operation

LSL

363,800 lb + 110,200 lb 36.1-68.9 ft 27.6 ft 32.2 ft/s 360° ASME B30.5																								
492.1 ft								502.0 ft																
LSL_5		LSL_7		LSL_9		LSL_11		LSL_13		LSL_15		LSL_5		LSL_7		LSL_9		LSL_11		LSL_13		LSL_15		
0 lb		0 lb - 716.6 klb								0 lb		0 lb - 716.6 klb												
ft	1,000 lb																						ft	
52.5	191.8	199.5	210.5	249.1	262.4	284.4	310.9	-	-	-	-	-	-	-	-	-	-	-	-	-	-	-	-	52.5
55.8	182.4	199.0	210.5	249.1	262.4	284.4	310.9	179.7	189.6	199.5	238.1	249.1	269.0	293.2	293.2	293.2	293.2	293.2	293.2	293.2	293.2	293.2	293.2	55.8
59.1	174.2	198.4	210.5	249.1	262.4	284.4	310.9	169.8	189.6	199.5	238.1	249.1	269.0	293.2	293.2	293.2	293.2	293.2	293.2	293.2	293.2	293.2	293.2	59.1
65.6	154.3	198.4	209.4	249.1	262.4	282.2	310.9	149.9	188.5	198.4	235.9	249.1	269.0	293.2	293.2	293.2	293.2	293.2	293.2	293.2	293.2	293.2	293.2	65.6
72.2	136.7	197.3	208.3	246.9	262.4	282.2	310.9	132.3	187.4	198.4	235.9	249.1	269.0	293.2	293.2	293.2	293.2	293.2	293.2	293.2	293.2	293.2	293.2	72.2
78.7	121.3	196.2	208.3	246.9	262.4	282.2	308.6	117.9	186.3	197.3	235.9	249.1	269.0	293.2	293.2	293.2	293.2	293.2	293.2	293.2	293.2	293.2	293.2	78.7
85.3	108.7	196.2	207.2	246.9	260.1	282.2	307.5	105.2	186.3	196.2	235.9	246.9	266.8	291.0	291.0	291.0	291.0	291.0	291.0	291.0	291.0	291.0	291.0	85.3
91.9	97.0	195.1	206.1	246.9	260.1	280.0	306.4	93.5	185.2	196.2	233.7	246.9	266.8	288.8	288.8	288.8	288.8	288.8	288.8	288.8	288.8	288.8	288.8	91.9
98.4	86.4	194.0	205.0	244.7	257.9	280.0	304.2	83.1	184.1	195.1	233.7	244.7	264.6	287.7	287.7	287.7	287.7	287.7	287.7	287.7	287.7	287.7	287.7	98.4
111.5	69.2	191.8	202.8	241.8	255.0	274.1	302.0	66.1	182.6	192.9	230.8	241.8	260.1	285.5	285.5	285.5	285.5	285.5	285.5	285.5	285.5	285.5	285.5	111.5
124.7	54.1	189.2	200.6	238.8	248.4	265.3	297.6	51.1	180.8	191.1	227.8	237.4	254.3	282.2	282.2	282.2	282.2	282.2	282.2	282.2	282.2	282.2	282.2	124.7
137.8	41.0	186.3	198.4	235.9	242.5	257.9	288.8	38.1	178.6	189.6	224.9	231.5	246.9	274.8	274.8	274.8	274.8	274.8	274.8	274.8	274.8	274.8	274.8	137.8
150.9	30.9	182.6	194.7	230.0	235.2	248.4	277.8	28.0	175.6	185.9	219.0	224.1	237.4	264.6	264.6	264.6	264.6	264.6	264.6	264.6	264.6	264.6	264.6	150.9
164.0	21.6	178.9	188.9	224.4	228.5	240.3	267.5	18.8	172.4	182.6	213.8	218.9	227.5	255.7	255.7	255.7	255.7	255.7	255.7	255.7	255.7	255.7	255.7	164.0
177.2	13.2	175.3	185.2	219.4	220.5	229.3	250.9	10.6	168.7	179.7	208.3	212.7	220.5	242.5	242.5	242.5	242.5	242.5	242.5	242.5	242.5	242.5	242.5	177.2
180.4	11.5	173.1	183.2	218.3	218.8	226.5	246.0	8.8	167.9	177.7	207.1	211.3	218.3	238.1	238.1	238.1	238.1	238.1	238.1	238.1	238.1	238.1	238.1	180.4
183.7	9.7	172.2	181.1	217.2	217.2	223.8	241.2	-	167.2	175.6	205.8	209.8	216.1	233.7	233.7	233.7	233.7	233.7	233.7	233.7	233.7	233.7	233.7	183.7
190.3	-	170.4	178.6	215.0	213.8	220.5	231.5	-	165.7	173.8	203.2	206.9	212.7	224.9	224.9	224.9	224.9	224.9	224.9	224.9	224.9	224.9	224.9	190.3
203.4	-	165.7	173.4	208.7	207.6	212.4	212.4	-	161.7	169.0	198.4	199.2	205.8	206.5	206.5	206.5	206.5	206.5	206.5	206.5	206.5	206.5	206.5	203.4
216.5	-	162.0	168.7	200.6	201.7	202.8	194.4	-	158.7	165.3	194.0	194.0	198.4	188.9	188.9	188.9	188.9	188.9	188.9	188.9	188.9	188.9	188.9	216.5
229.7	-	156.5	164.2	185.9	187.0	186.7	177.5	-	152.9	160.9	180.8	180.8	182.2	172.0	172.0	172.0	172.0	172.0	172.0	172.0	172.0	172.0	172.0	229.7
242.8	-	151.8	156.2	171.6	172.3	171.1	161.7	-	147.7	152.6	167.6	167.0	166.8	156.5	156.5	156.5	156.5	156.5	156.5	156.5	156.5	156.5	156.5	242.8
255.9	-	146.6	144.4	157.6	157.6	156.5	147.3	-	141.1	140.0	153.2	153.2	152.1	142.2	142.2	142.2	142.2	142.2	142.2	142.2	142.2	142.2	142.2	255.9
269.0	-	137.8	132.5	144.4	144.4	144.0	133.4	-	134.1	129.0	140.7	140.7	139.6	129.0	129.0	129.0	129.0	129.0	129.0	129.0	129.0	129.0	129.0	269.0
282.2	-	128.2	121.6	132.6	132.6	132.3	120.9	-	123.8	118.3	129.0	129.0	127.1	116.5	116.5	116.5	116.5	116.5	116.5	116.5	116.5	116.5	116.5	282.2
295.3	-	117.9	111.3	122.4	122.4	121.3	109.6	-	113.5	108.0	117.9	117.9	114.6	105.6	105.6	105.6	105.6	105.6	105.6	105.6	105.6	105.6	105.6	295.3
308.4	-	108.0	101.8	112.4	112.4	109.8	99.6	-	104.3	98.5	108.7	108.4	102.0	95.2	95.2	95.2	95.2	95.2	95.2	95.2	95.2	95.2	95.2	308.4
321.5	-	98.8	92.6	102.7	102.7	98.5	90.5	-	95.1	89.4	99.4	98.8	90.1	86.3	86.3	86.3	86.3	86.3	86.3	86.3	86.3	86.3	86.3	321.5
334.6	-	90.4	84.4	93.7	93.7	88.0	81.8	-	86.9	80.9	90.4	89.3	78.9	77.4	77.4	77.4	77.4	77.4	77.4	77.4	77.4	77.4	77.4	334.6
347.8	-	79.7	76.9	85.5	85.3	78.3	73.6	-	75.7	73.6	82.2	78.1	69.1	69.4	69.4	69.4	69.4	69.4	69.4	69.4	69.4	69.4	69.4	347.8
360.9	-	67.4	67.8	77.6	76.3	69.1	66.0	-	63.9	65.3	72.5	67.5	59.8	61.9	61.9	61.9	61.9	61.9	61.9	61.9	61.9	61.9	61.9	360.9
374.0	-	54.9	56.2	70.1	66.6	60.8	58.7	-	51.8	56.2	62.2	57.8	51.4	54.7	54.7	54.7	54.7	54.7	54.7	54.7	54.7	54.7	54.7	374.0
387.1	-	45.0	46.1	63.5	57.8	53.6	51.8	-	41.8	45.3	53.1	49.1	44.2	47.8	47.8	47.8	47.8	47.8	47.8	47.8	47.8	47.8	47.8	387.1
400.3	-	36.2	38.1	57.3	49.7	47.0	45.8	-	33.1	35.7	44.5	40.9	37.5	41.8	41.8	41.8	41.8	41.8	41.8	41.8	41.8	41.8	41.8	400.3
413.4	-	29.1	30.9	51.6	42.3	41.0	40.0	-	25.4	28.7	37.0	34.0	31.7	35.9	35.9	35.9	35.9	35.9	35.9	35.9	35.9	35.9	35.9	413.4
426.5	-	24.7	25.4	46.7	36.6	36.2	34.6	-	20.5	22.9	30.7	27.9	27.2	30.6	30.6	30.6	30.6	30.6	30.6	30.6	30.6	30.6	30.6	426.5
433.1	-	22.7	23.1	44.3	33.7	33.7	32.2	-	18.1	20.1	27.6	24.9	24.9	28.2	28.2	28.2	28.2	28.2	28.2	28.2	28.2	28.2	28.2	433.1
439.6	-	-	-	-	-	-	-	-	15.9	17.6	25.1	22.5	23.1	25.8	25.8	25.8	25.8	25.8	25.8	25.8	25.8	25.8	25.8	439.6

0 lb | 143,300 lb | 275,600 lb | 363,800 lb | 452,000 lb | 540,200 lb | 628,400 lb | 716,600 lb

LSL_5 – LSL_7: 36.1 ft – 62.3 ft

LSL_9 – LSL_13: 36.1 ft – 68.9 ft

LSL_15: 42.7 ft – 68.9 ft

LSL_15: 496,100 lb + 110,200 lb

Operation

363,800 lb + 110,200 lb 36.1-68.9 ft 27.6 ft 32.2 ft/s 360° ASME B30.5															
511.8 ft 521.7 ft															
LSL_5 LSL_7 LSL_9 LSL_11 LSL_13 LSL_15 LSL_5 LSL_7 LSL_9 LSL_11 LSL_13 LSL_15															
0 lb 0 lb - 716.6 klb 0 lb 0 lb - 716.6 klb															
ft	1,000 lb													ft	
55.8	169.8	174.2	188.5	224.9	238.1	255.7	282.2	160.9	166.4	178.6	213.8	224.9	240.3	266.8	55.8
59.1	166.4	174.2	187.4	224.9	238.1	255.7	282.2	159.8	165.3	177.5	213.8	222.7	240.3	266.8	59.1
65.6	147.7	173.1	187.4	224.9	238.1	255.7	280.0	143.3	164.2	177.5	212.7	222.7	240.3	266.8	65.6
72.2	131.2	172.0	186.3	224.9	238.1	255.7	280.0	126.8	164.2	176.4	212.7	222.7	238.1	266.8	72.2
78.7	115.7	172.0	185.2	222.7	238.1	255.7	280.0	112.4	163.1	175.3	211.6	222.7	238.1	264.6	78.7
85.3	103.8	170.9	185.2	220.5	235.9	255.7	278.9	100.3	162.0	175.3	210.5	220.5	235.9	263.5	85.3
91.9	92.2	169.8	184.1	219.4	233.7	253.5	277.8	88.8	162.0	174.2	210.5	219.4	235.9	262.4	91.9
98.4	82.0	168.7	184.1	217.2	229.3	253.5	275.6	78.7	160.9	174.2	209.4	217.2	233.7	261.2	98.4
111.5	65.3	166.4	181.9	212.7	224.9	249.1	273.4	62.1	158.7	172.0	206.5	213.5	229.3	259.0	111.5
124.7	50.4	164.6	180.0	207.6	219.4	244.0	269.0	47.4	156.9	170.1	202.5	208.7	224.5	255.7	124.7
137.8	37.5	163.1	178.6	201.7	212.7	238.1	263.1	34.6	155.4	168.7	197.3	202.8	219.4	250.6	137.8
150.9	27.5	160.2	174.9	194.7	204.3	228.8	255.7	24.6	153.2	165.7	192.0	196.2	211.3	244.7	150.9
164.0	18.4	157.1	172.0	187.0	197.3	220.1	248.4	15.6	150.6	163.1	185.9	188.9	202.8	237.4	164.0
173.9	12.4	154.9	169.4	182.3	192.4	215.3	242.5	9.5	148.4	160.7	182.1	184.5	197.9	231.5	173.9
177.2	10.4	154.3	168.7	180.8	190.7	213.8	240.3	-	147.7	159.8	180.8	183.0	196.2	229.3	177.2
190.3	-	150.6	165.7	173.1	181.9	207.2	229.3	-	144.8	156.9	173.8	175.3	187.4	220.5	190.3
203.4	-	147.3	162.8	166.1	173.8	198.4	211.6	-	141.8	154.0	167.2	167.9	180.0	204.3	203.4
216.5	-	144.4	159.8	158.7	166.4	191.8	194.7	-	138.9	151.0	162.0	162.0	172.0	188.5	216.5
229.7	-	139.6	156.9	151.4	159.1	177.8	178.6	-	136.0	148.1	155.8	155.1	165.3	173.1	229.7
242.8	-	134.8	150.6	142.2	148.8	164.2	163.6	-	131.7	144.4	147.7	146.6	153.2	158.4	242.8
255.9	-	131.2	140.0	131.2	137.8	149.9	149.9	-	126.8	135.6	136.7	134.5	135.6	144.8	255.9
269.0	-	126.8	129.0	119.4	126.8	137.4	136.7	-	122.4	124.6	125.7	122.7	118.7	132.3	269.0
282.2	-	120.9	118.5	108.2	115.7	124.2	124.2	-	116.8	114.3	115.0	111.0	103.3	119.8	282.2
295.3	-	113.5	108.7	97.4	104.5	110.2	112.9	-	110.2	104.9	104.7	99.4	88.8	108.6	295.3
308.4	-	104.7	99.1	86.4	93.5	98.3	103.0	-	101.3	95.5	93.9	87.5	74.9	98.5	308.4
321.5	-	95.7	90.0	75.5	82.4	86.4	93.7	-	92.4	86.5	82.9	76.1	61.9	89.3	321.5
334.6	-	86.9	81.4	64.6	71.2	75.0	85.0	-	83.6	77.8	71.9	64.6	50.0	80.5	334.6
347.8	-	79.7	74.0	54.7	60.9	65.0	76.7	-	76.2	70.3	60.8	54.7	39.7	72.5	347.8
360.9	-	71.4	66.8	45.2	51.3	55.6	68.7	-	68.3	63.5	50.5	45.4	30.6	65.0	360.9
374.0	-	62.2	59.7	36.6	42.3	47.0	60.6	-	56.9	56.9	40.8	36.6	22.3	57.9	374.0
387.1	-	51.7	49.0	29.0	34.4	39.6	52.7	-	45.7	45.9	32.3	28.8	15.0	51.4	387.1
400.3	-	42.0	39.1	21.8	26.9	32.9	45.8	-	36.4	36.0	24.4	21.5	9.0	44.9	400.3
413.4	-	34.2	31.5	15.4	20.5	26.9	39.4	-	27.6	27.8	17.2	14.8	-	38.5	413.4
426.5	-	26.7	24.8	9.7	14.9	22.2	33.5	-	20.2	20.9	11.0	9.0	-	32.2	426.5
429.8	-	24.8	23.1	-	13.5	21.0	32.2	-	18.5	19.1	9.5	-	-	30.9	429.8
439.6	-	19.8	18.8	-	9.7	18.1	28.5	-	14.1	14.6	-	-	-	26.9	439.6
449.5	-	15.2	15.0	-	-	15.7	25.1	-	10.8	10.8	-	-	-	23.1	449.5
452.8	-	-	-	-	-	-	-	-	9.7	9.5	-	-	-	22.0	452.8
459.3	-	-	-	-	-	-	-	-	-	-	-	-	-	19.8	459.3

0 lb 143,300 lb 275,600 lb 363,800 lb 452,000 lb 540,200 lb 628,400 lb 716,600 lb

LSL_5 – LSL_7: 36.1 ft – 62.3 ft

LSL_9 – LSL_13: 36.1 ft – 68.9 ft

LSL_15: 42.7 ft – 68.9 ft

LSL_15: 496,100 lb + 110,200 lb

Operation

LSL

363,800 lb + 110,200 lb 36.1-68.9 ft 27.6 ft 32.2 ft/s 360° ASME B30.5																	
531.5 ft					541.3 ft					551.2 ft			561.0 ft				
LSL_9		LSL_11		LSL_13		LSL_15		LSL_9		LSL_11		LSL_13		LSL_15			
0 lb		0 lb - 716.6 klb				0 lb		0 lb - 716.6 klb				0 lb		0 - 716.6 klb			
ft																	
1,000 lb																	
ft																	
59.1	155.4	201.7	211.6	229.3	253.5	151.0	189.6	199.5	216.1	240.3	144.4	202.8	229.3	140.0	191.8	215.0	59.1
65.6	135.6	200.6	210.5	227.1	253.5	131.2	188.5	199.5	216.1	240.3	125.7	201.7	229.3	121.3	190.7	215.0	65.6
72.2	119.0	199.5	210.5	227.1	251.3	114.6	187.4	198.4	215.0	238.1	110.0	201.7	227.1	105.6	189.6	213.8	72.2
78.7	105.4	199.5	210.5	227.1	251.3	101.2	187.4	198.4	215.0	238.1	95.9	201.7	227.1	91.5	189.6	212.7	78.7
85.3	92.4	198.4	209.4	227.1	250.2	88.4	186.3	198.4	215.0	237.0	83.1	200.6	226.0	78.9	189.6	212.2	85.3
91.9	80.7	198.4	208.3	224.9	249.1	76.9	186.3	197.3	213.8	235.9	71.9	199.5	224.9	67.9	188.5	211.6	91.9
98.4	70.5	197.3	207.2	224.9	248.0	66.8	185.2	196.2	212.7	234.8	61.7	199.5	223.8	57.8	187.4	210.0	98.4
111.5	53.5	195.1	204.3	221.2	245.8	50.0	183.7	194.7	211.3	232.6	45.0	198.8	221.6	41.3	186.7	207.8	111.5
124.7	38.5	192.2	200.3	217.2	242.5	35.2	181.9	192.2	209.1	229.3	30.3	196.9	219.4	26.7	185.2	205.6	124.7
137.8	25.6	188.5	195.1	212.7	238.1	22.3	179.7	188.5	206.1	224.9	17.6	194.0	216.4	14.1	183.0	202.5	137.8
141.1	23.0	187.4	194.0	211.1	237.0	19.7	178.9	187.4	205.0	223.8	15.0	192.9	215.5	11.2	181.9	201.7	141.1
147.6	18.0	185.2	191.8	207.8	234.8	14.5	177.2	184.9	202.5	221.6	9.7	190.7	213.7	-	180.1	200.3	147.6
150.9	15.4	184.1	189.6	206.1	233.7	11.9	176.4	183.5	201.2	220.5	-	189.6	212.7	-	179.2	199.5	150.9
154.2	12.9	183.0	187.9	204.5	231.9	9.3	175.8	182.2	199.8	219.4	-	188.5	211.6	-	178.4	198.4	154.2
157.5	10.4	181.9	186.3	202.8	230.2	-	175.3	180.8	198.4	218.3	-	187.4	210.5	-	177.5	197.3	157.5
164.0	-	179.3	183.4	198.8	226.6	-	173.1	178.2	195.1	216.1	-	184.5	208.0	-	175.3	194.6	164.0
177.2	-	174.2	177.5	192.9	219.7	-	168.7	173.1	189.6	209.8	-	179.7	202.1	-	170.9	188.9	177.2
190.3	-	169.8	172.3	184.8	213.8	-	165.7	168.7	184.5	203.9	-	174.9	196.2	-	166.4	183.0	190.3
203.4	-	164.2	166.1	177.1	199.2	-	162.4	163.1	179.7	191.4	-	170.9	185.9	-	162.4	176.4	203.4
216.5	-	159.8	160.9	170.9	184.1	-	158.7	158.7	175.3	177.5	-	166.4	173.8	-	158.7	166.4	216.5
229.7	-	153.6	154.0	164.7	168.7	-	155.4	153.2	163.1	163.1	-	160.2	159.8	-	152.3	153.2	229.7
242.8	-	146.6	146.2	154.3	155.4	-	148.8	145.9	149.9	149.9	-	148.1	146.6	-	142.9	140.7	242.8
255.9	-	137.8	136.7	141.1	142.2	-	137.8	137.8	136.7	137.1	-	135.6	134.1	-	131.2	128.6	255.9
269.0	-	127.5	124.9	124.2	129.0	-	126.8	126.0	124.9	124.6	-	124.6	122.4	-	120.2	116.8	269.0
282.2	-	117.1	113.7	108.5	117.2	-	116.1	114.5	113.9	112.4	-	113.9	111.0	-	108.9	105.9	282.2
295.3	-	106.5	103.0	94.1	106.3	-	105.6	103.0	103.4	102.4	-	103.4	100.7	-	99.2	95.8	295.3
308.4	-	96.1	91.5	80.8	96.3	-	96.2	91.2	90.8	92.2	-	94.0	90.4	-	89.7	85.8	308.4
321.5	-	85.5	80.0	68.1	86.9	-	87.2	79.4	78.0	82.6	-	85.1	80.9	-	80.6	76.5	321.5
334.6	-	75.0	68.6	56.2	78.0	-	78.7	67.5	65.5	73.9	-	75.8	71.4	-	72.5	68.0	334.6
347.8	-	63.3	58.1	45.7	70.1	-	70.9	56.7	54.5	65.7	-	65.6	61.3	-	64.9	59.7	347.8
360.9	-	52.6	48.2	36.1	62.8	-	61.5	46.6	44.0	58.5	-	55.7	52.7	-	57.1	50.6	360.9
374.0	-	42.3	38.8	27.1	55.1	-	50.5	37.0	34.4	51.6	-	46.5	44.5	-	48.1	42.1	374.0
387.1	-	33.1	30.2	19.5	47.2	-	40.4	28.5	26.0	45.0	-	38.0	36.6	-	39.7	34.2	387.1
400.3	-	25.0	22.6	12.8	40.0	-	31.2	20.5	18.4	38.6	-	29.9	29.5	-	31.5	27.1	400.3
406.8	-	21.1	18.9	9.7	36.4	-	27.0	16.8	15.0	35.3	-	26.1	26.0	-	27.7	23.6	406.8
413.4	-	17.2	15.2	-	33.1	-	22.7	13.0	12.3	32.0	-	22.5	22.9	-	23.8	20.4	413.4
419.9	-	13.8	12.0	-	30.1	-	18.9	9.7	9.5	28.7	-	19.1	19.8	-	20.4	17.3	419.9
426.5	-	10.4	8.8	-	27.1	-	15.2	-	-	25.4	-	15.7	16.8	-	16.9	14.1	426.5
436.4	-	-	-	-	23.0	-	10.1	-	-	21.1	-	10.9	12.6	-	11.7	9.7	436.4
439.6	-	-	-	-	21.7	-	-	-	-	19.6	-	9.5	11.1	-	10.4	-	439.6
442.9	-	-	-	-	20.3	-	-	-	-	18.3	-	-	9.7	-	-	-	442.9
452.8	-	-	-	-	16.5	-	-	-	-	14.6	-	-	-	-	-	-	452.8
465.9	-	-	-	-	12.1	-	-	-	-	9.7	-	-	-	-	-	-	465.9

0 lb 143,300 lb 275,600 lb 363,800 lb 452,000 lb 540,200 lb 628,400 lb 716,600 lb

LSL_9 – LSL_13: 36.1 ft – 68.9 ft

LSL_15: 42.7 ft – 68.9 ft

LSL_15: 496,100 lb + 110,200 lb

FIXED FLY JIB



Operation

SH+LF, LH+LF

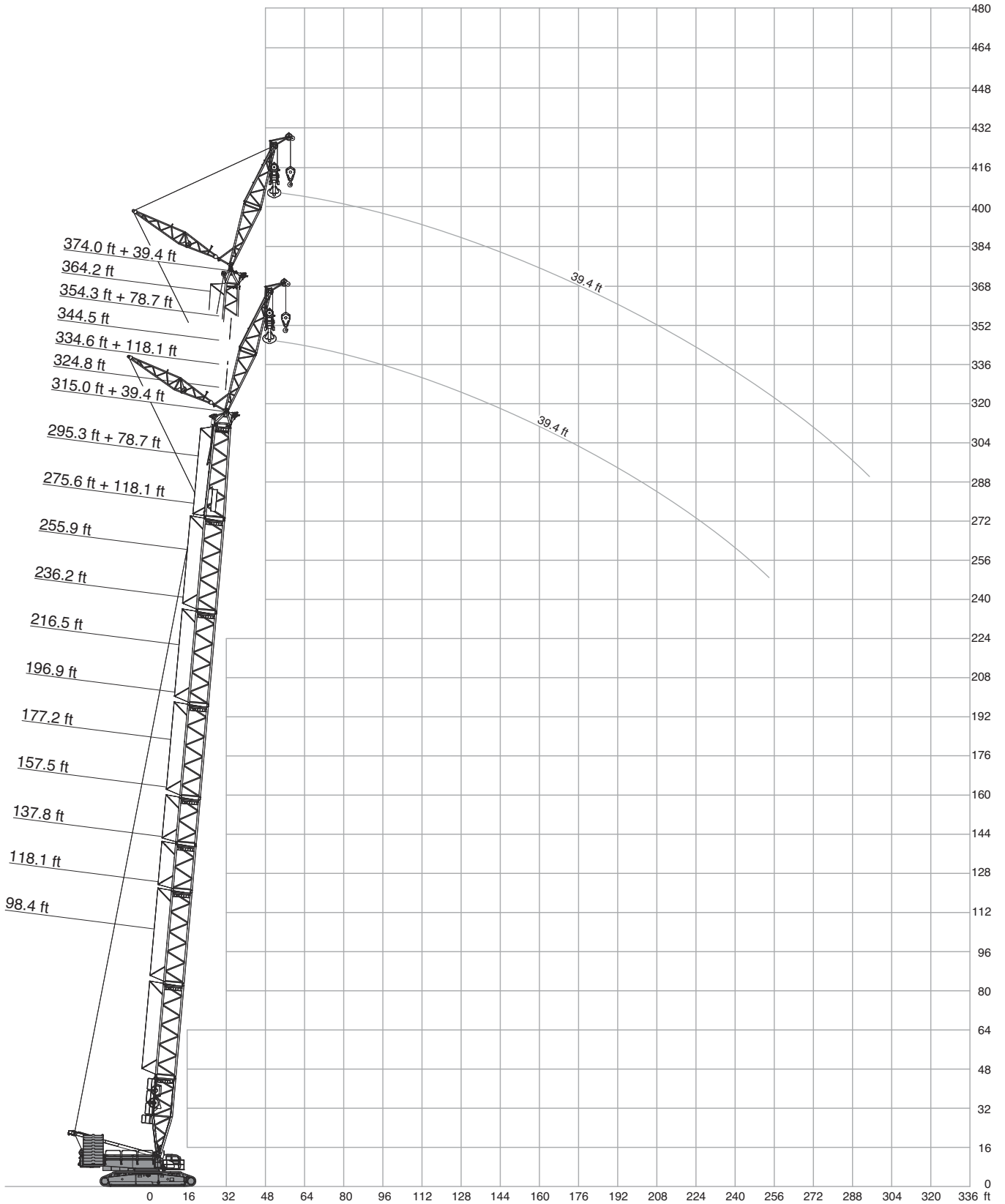

Operation

SH+LF

+ 39.4-118.1 ft		27.6 ft		32.2 ft/s		360°		ASME B30.5																		
98.4 ft										118.1 ft																
SH+LF_1																										
39.4 ft				78.7 ft				118.1 ft				39.4 ft				78.7 ft				118.1 ft						
15°			20°			30°			15°			20°			30°			15°			20°			30°		
ft																										
1,000 lb																										
ft																										
29.5	377.0	-	-	-	-	-	-	-	-	-	-	-	-	-	-	-	-	-	-	29.5						
32.8	352.7	-	-	-	-	-	-	-	-	-	-	-	-	-	-	-	-	-	-	32.8						
36.1	331.8	262.4	-	-	-	-	-	-	-	-	-	-	-	-	-	-	-	-	-	36.1						
39.4	310.9	249.1	169.8	-	-	-	-	-	-	-	-	-	-	-	-	-	-	-	-	39.4						
42.7	294.3	238.1	163.7	-	-	-	-	-	-	-	-	-	-	-	-	-	-	-	-	42.7						
45.9	277.8	227.1	157.6	173.1	-	-	-	-	-	-	-	-	-	-	-	-	-	-	-	45.9						
52.5	251.3	209.4	147.7	156.5	126.8	-	-	-	-	-	-	-	-	-	-	-	-	-	-	52.5						
59.1	231.5	192.9	138.9	142.2	116.8	-	-	-	-	-	-	-	-	-	-	-	-	-	-	59.1						
62.3	222.7	186.8	135.6	136.1	112.9	79.6	106.8	-	-	-	-	-	-	-	-	-	-	-	-	62.3						
65.6	213.8	180.8	132.3	130.1	108.9	77.2	102.3	-	-	-	-	-	-	-	-	-	-	-	-	65.6						
68.9	206.1	174.7	129.0	125.1	105.2	75.0	98.4	81.4	-	-	-	-	-	-	-	-	-	-	-	68.9						
72.2	198.4	168.7	125.7	120.2	101.4	72.8	94.6	78.5	-	-	-	-	-	-	-	-	-	-	-	72.2						
78.7	185.2	158.7	120.2	111.3	94.8	68.8	87.5	73.0	-	-	-	-	-	-	-	-	-	-	-	78.7						
85.3	173.1	151.0	114.6	104.7	89.1	65.3	81.1	68.3	48.5	-	-	-	-	-	-	-	-	-	-	85.3						
88.6	168.7	147.2	112.4	101.4	86.5	63.7	78.5	66.1	47.2	-	-	-	-	-	-	-	-	-	-	88.6						
91.9	164.2	143.3	110.2	98.1	84.0	62.2	75.8	63.9	45.9	-	-	-	-	-	-	-	-	-	-	91.9						
98.4	155.4	136.7	107.1	92.4	79.6	59.3	71.0	60.2	43.4	-	-	-	-	-	-	-	-	-	-	98.4						
111.5	141.1	125.7	101.2	82.7	72.1	54.7	62.8	53.8	39.2	-	-	-	-	-	-	-	-	-	-	111.5						
124.7	126.8	117.9	-	75.0	65.9	50.7	56.4	48.7	35.7	-	-	-	-	-	-	-	-	-	-	124.7						
128.0	122.4	-	-	73.4	64.7	49.9	55.1	47.6	35.1	-	-	-	-	-	-	-	-	-	-	128.0						
131.2	117.9	-	-	71.8	63.4	49.2	53.8	46.5	34.4	-	-	-	-	-	-	-	-	-	-	131.2						
137.8	-	-	-	68.6	60.8	47.6	51.1	44.3	33.1	-	-	-	-	-	-	-	-	-	-	137.8						
141.1	-	-	-	67.3	59.9	47.1	50.0	43.4	32.5	-	-	-	-	-	-	-	-	-	-	141.1						
147.6	-	-	-	64.8	57.9	46.0	47.7	41.7	31.3	-	-	-	-	-	-	-	-	-	-	147.6						
150.9	-	-	-	63.5	56.9	45.4	46.5	40.8	30.6	-	-	-	-	-	-	-	-	-	-	150.9						
164.0	-	-	-	59.5	53.8	-	42.8	37.7	28.7	-	-	-	-	-	-	-	-	-	-	164.0						
167.3	-	-	-	58.6	-	-	42.0	37.0	28.2	-	-	-	-	-	-	-	-	-	-	167.3						
177.2	-	-	-	-	-	-	39.7	35.1	26.9	-	-	-	-	-	-	-	-	-	-	177.2						
183.7	-	-	-	-	-	-	38.4	34.1	26.3	-	-	-	-	-	-	-	-	-	-	183.7						
190.3	-	-	-	-	-	-	37.0	33.1	25.8	-	-	-	-	-	-	-	-	-	-	190.3						
200.1	-	-	-	-	-	-	35.5	31.7	-	-	-	-	-	-	-	-	-	-	-	200.1						
203.4	-	-	-	-	-	-	35.1	-	-	-	-	-	-	-	-	-	-	-	-	203.4						
206.7	-	-	-	-	-	-	34.6	-	-	-	-	-	-	-	-	-	-	-	-	206.7						
216.5	-	-	-	-	-	-	-	-	-	-	-	-	-	-	-	-	-	-	-	216.5						
223.1	-	-	-	-	-	-	-	-	-	-	-	-	-	-	-	-	-	-	-	223.1						

	99,200 lb	187,400 lb	275,600 lb	363,800 lb	408,000 lb	452,000 lb
	0 lb			66,100 lb	110,200 lb	

Operation

SH+LF

+ 39.4-118.1 ft		27.6 ft		32.2 ft/s		360°		ASME B30.5															
157.5 ft										177.2 ft													
SH+LF_1																							
39.4 ft				78.7 ft				118.1 ft				39.4 ft				78.7 ft				118.1 ft			
15°		20°		30°		15°		20°		30°		15°		20°		30°		15°		20°		30°	
1,000 lb																							
ft																							ft
36.1	368.2	-	-	-	-	-	-	-	-	-	-	-	-	-	-	-	-	-	-	-	-	-	36.1
39.4	350.5	269.0	-	-	-	-	-	-	-	-	-	-	-	-	-	-	-	-	-	-	-	-	39.4
42.7	336.2	260.1	-	-	-	-	-	-	-	-	-	-	-	-	-	-	-	-	-	-	-	-	42.7
45.9	321.9	251.3	166.4	-	-	-	-	-	-	-	-	-	-	-	-	-	-	-	-	-	-	-	45.9
49.2	308.6	242.5	162.6	178.6	-	-	-	-	-	-	-	-	-	-	-	-	-	-	-	-	-	-	49.2
52.5	295.4	233.7	158.7	172.0	-	-	-	-	-	-	-	-	-	-	-	-	-	-	-	-	-	-	52.5
55.8	284.4	227.1	154.9	165.3	130.1	-	-	-	-	-	-	-	-	-	-	-	-	-	-	-	-	-	55.8
59.1	273.4	220.5	151.0	158.7	125.7	-	-	-	-	-	-	-	-	-	-	-	-	-	-	-	-	-	59.1
62.3	264.6	214.4	147.7	153.2	121.8	-	-	-	-	-	-	-	-	-	-	-	-	-	-	-	-	-	62.3
65.6	255.7	208.3	144.4	147.7	117.9	-	-	-	-	-	-	-	-	-	-	-	-	-	-	-	-	-	65.6
68.9	248.0	202.8	141.6	142.7	114.6	78.0	104.5	-	-	-	-	-	-	-	-	-	-	-	-	-	-	-	68.9
72.2	240.3	197.3	138.9	137.8	111.3	76.3	101.0	82.0	-	-	-	-	-	-	-	-	-	-	-	-	-	-	72.2
75.5	232.6	192.4	136.1	133.4	108.6	74.6	97.9	79.8	-	-	-	-	-	-	-	-	-	-	-	-	-	-	75.5
78.7	224.9	187.4	133.4	129.0	105.8	73.0	94.8	77.6	-	-	-	-	-	-	-	-	-	-	-	-	-	-	78.7
85.3	207.2	178.6	129.0	121.3	100.3	69.9	89.5	73.4	-	-	-	-	-	-	-	-	-	-	-	-	-	-	85.3
91.9	186.3	170.9	124.6	114.6	95.5	67.2	84.4	69.7	47.4	-	-	-	-	-	-	-	-	-	-	-	-	-	91.9
98.4	168.7	163.1	120.2	109.3	91.1	64.6	79.8	66.4	45.4	-	-	-	-	-	-	-	-	-	-	-	-	-	98.4
111.5	140.0	141.1	113.5	99.0	83.3	60.2	71.7	60.2	41.9	-	-	-	-	-	-	-	-	-	-	-	-	-	111.5
124.7	117.9	119.0	108.2	90.4	76.9	56.4	64.8	55.1	38.8	-	-	-	-	-	-	-	-	-	-	-	-	-	124.7
137.8	101.6	102.3	103.2	83.3	71.7	53.1	59.5	50.7	36.2	-	-	-	-	-	-	-	-	-	-	-	-	-	137.8
150.9	88.0	88.4	89.1	77.4	67.0	50.5	55.3	47.0	33.7	-	-	-	-	-	-	-	-	-	-	-	-	-	150.9
154.2	84.9	85.3	86.0	76.1	66.0	49.9	54.3	46.2	33.2	-	-	-	-	-	-	-	-	-	-	-	-	-	154.2
164.0	76.7	77.2	-	72.1	63.1	48.3	51.1	43.9	31.7	-	-	-	-	-	-	-	-	-	-	-	-	-	164.0
167.3	74.4	74.7	-	71.0	62.2	47.8	50.3	43.2	31.3	-	-	-	-	-	-	-	-	-	-	-	-	-	167.3
173.9	69.8	69.9	-	68.8	60.4	46.8	48.5	41.7	30.4	-	-	-	-	-	-	-	-	-	-	-	-	-	173.9
177.2	67.5	-	-	67.9	59.7	46.3	47.6	41.0	30.0	-	-	-	-	-	-	-	-	-	-	-	-	-	177.2
180.4	65.3	-	-	67.0	59.0	45.9	46.8	40.4	29.7	-	-	-	-	-	-	-	-	-	-	-	-	-	180.4
190.3	-	-	-	64.2	56.9	44.8	44.5	38.6	28.7	-	-	-	-	-	-	-	-	-	-	-	-	-	190.3
193.6	-	-	-	62.4	56.3	44.5	43.9	38.0	28.3	-	-	-	-	-	-	-	-	-	-	-	-	-	193.6
196.9	-	-	-	60.6	55.8	-	43.2	37.5	28.0	-	-	-	-	-	-	-	-	-	-	-	-	-	196.9
203.4	-	-	-	57.1	54.7	-	41.9	36.4	27.3	-	-	-	-	-	-	-	-	-	-	-	-	-	203.4
206.7	-	-	-	55.5	54.1	-	41.3	35.9	27.1	-	-	-	-	-	-	-	-	-	-	-	-	-	206.7
210.0	-	-	-	53.9	53.6	-	40.7	35.5	26.8	-	-	-	-	-	-	-	-	-	-	-	-	-	210.0
216.5	-	-	-	50.7	-	-	39.5	34.6	26.2	-	-	-	-	-	-	-	-	-	-	-	-	-	216.5
219.8	-	-	-	49.2	-	-	39.0	34.2	26.0	-	-	-	-	-	-	-	-	-	-	-	-	-	219.8
226.4	-	-	-	-	-	-	38.0	33.5	25.6	-	-	-	-	-	-	-	-	-	-	-	-	-	226.4
229.7	-	-	-	-	-	-	37.5	33.1	25.4	-	-	-	-	-	-	-	-	-	-	-	-	-	229.7
236.2	-	-	-	-	-	-	36.6	32.4	-	-	-	-	-	-	-	-	-	-	-	-	-	-	236.2
242.8	-	-	-	-	-	-	35.7	31.7	-	-	-	-	-	-	-	-	-	-	-	-	-	-	242.8
249.3	-	-	-	-	-	-	35.1	31.3	-	-	-	-	-	-	-	-	-	-	-	-	-	-	249.3
255.9	-	-	-	-	-	-	34.4	-	-	-	-	-	-	-	-	-	-	-	-	-	-	-	255.9
265.7	-	-	-	-	-	-	-	-	-	-	-	-	-	-	-	-	-	-	-	-	-	-	265.7
269.0	-	-	-	-	-	-	-	-	-	-	-	-	-	-	-	-	-	-	-	-	-	-	269.0
272.3	-	-	-	-	-	-	-	-	-	-	-	-	-	-	-	-	-	-	-	-	-	-	272.3

99,200 lb
 187,400 lb
 275,600 lb
 363,800 lb
 408,000 lb
 452,000 lb

0 lb
 66,100 lb
 110,200 lb

Operation

SH+LF

39.4-118.1 ft		27.6 ft		32.2 ft/s		360°		ASME B30.5											
196.9 ft										216.5 ft									
SH+LF_1																			
39.4 ft			78.7 ft			118.1 ft			39.4 ft			78.7 ft			118.1 ft				
15°	20°	30°	15°	20°	30°	15°	20°	30°	15°	20°	30°	15°	20°	30°	15°	20°	30°		
1,000 lb																			
ft																		ft	
39.4	368.2	-	-	-	-	-	-	-	-	-	-	-	-	-	-	-	-	39.4	
42.7	354.9	271.2	-	-	-	-	-	-	-	-	-	361.6	-	-	-	-	-	42.7	
45.9	341.7	262.4	-	-	-	-	-	-	-	-	-	348.3	266.8	-	-	-	-	45.9	
49.2	329.6	254.6	166.4	-	-	-	-	-	-	-	-	337.3	259.0	-	-	-	-	49.2	
52.5	317.5	246.9	162.0	178.6	-	-	-	-	-	-	-	326.3	251.3	164.2	-	-	-	52.5	
55.8	306.4	240.3	159.3	172.5	-	-	-	-	-	-	-	314.2	244.7	160.9	175.3	-	-	55.8	
59.1	295.4	233.7	156.5	166.4	130.1	-	-	-	-	-	-	302.0	238.1	157.6	169.8	-	-	59.1	
62.3	286.6	227.1	153.2	161.5	126.2	-	-	-	-	-	-	285.5	232.6	154.9	164.8	127.9	-	62.3	
65.6	277.8	220.5	149.9	156.5	122.4	-	110.2	-	-	-	-	269.0	227.1	152.1	159.8	124.6	-	65.6	
68.9	264.6	216.1	147.2	151.6	119.6	-	107.0	-	-	-	-	255.7	222.1	149.9	154.9	121.3	107.8	68.9	
72.2	251.3	211.6	144.4	146.6	116.8	77.6	103.8	-	-	-	-	242.5	217.2	147.7	149.9	117.9	104.9	72.2	
75.5	239.2	206.7	142.2	142.2	113.5	76.1	101.0	81.1	-	-	-	230.9	212.2	145.0	146.1	115.2	76.7	75.5	
78.7	227.1	201.7	140.0	137.8	110.2	74.5	98.1	78.9	-	-	-	219.4	207.2	142.2	142.2	112.4	75.2	78.7	
85.3	201.7	192.9	135.6	131.2	105.8	71.9	92.8	75.2	-	-	-	199.5	199.5	137.8	134.5	108.2	72.8	85.3	
91.9	180.8	181.9	131.2	124.6	101.2	69.4	88.4	71.9	-	-	-	178.6	180.8	133.4	127.9	103.6	70.3	91.9	
95.1	172.0	173.1	129.0	121.3	99.1	68.2	86.2	70.3	46.7	-	-	169.8	171.4	131.7	125.1	101.5	69.1	95.1	
98.4	163.1	164.2	126.8	117.9	97.0	67.0	84.0	68.8	45.9	-	-	160.9	162.0	130.1	122.4	99.4	67.9	98.4	
111.5	134.5	135.6	120.2	108.0	89.3	62.8	76.3	63.1	42.8	-	-	132.3	133.4	123.5	111.3	91.9	63.9	111.5	
124.7	112.4	113.5	114.6	99.2	82.9	59.1	69.4	58.2	39.9	-	-	110.2	111.3	113.5	103.2	85.5	60.4	124.7	
137.8	95.5	96.3	97.7	91.7	77.4	56.0	63.9	54.0	37.5	-	-	93.5	94.4	95.9	95.5	80.0	57.3	137.8	
150.9	81.6	82.2	83.6	85.3	72.5	53.4	59.3	50.3	35.3	-	-	79.6	80.5	81.8	86.6	75.2	54.5	150.9	
164.0	69.9	70.5	71.7	76.7	68.6	50.9	55.6	47.2	33.5	-	-	67.5	68.3	69.4	75.0	71.0	52.0	164.0	
177.2	59.7	60.2	61.1	66.8	64.8	48.9	52.2	44.3	31.7	-	-	57.3	58.0	59.1	64.6	66.1	50.0	177.2	
180.4	57.6	58.0	58.9	64.6	63.4	48.5	51.4	43.7	31.3	-	-	55.2	55.8	56.8	62.3	63.8	49.6	180.4	
190.3	51.1	51.6	-	58.0	59.1	47.2	48.9	41.7	30.2	-	-	48.7	49.4	50.0	55.8	56.9	48.3	190.3	
196.9	47.5	48.0	-	54.1	54.9	46.4	47.5	40.6	29.5	-	-	45.1	45.6	46.1	51.9	52.9	47.4	196.9	
203.4	43.9	44.3	-	50.3	51.1	45.6	46.1	39.5	28.9	-	-	41.4	41.9	-	48.1	48.9	46.7	203.4	
213.3	39.2	-	-	45.3	46.0	44.8	44.2	38.1	28.1	-	-	36.6	37.0	-	42.9	43.8	44.4	213.3	
216.5	-	-	-	43.7	44.3	44.5	43.7	37.5	27.8	-	-	35.1	35.5	-	41.2	42.1	43.7	216.5	
219.8	-	-	-	42.2	42.8	44.1	43.1	37.0	27.4	-	-	33.7	34.0	-	39.8	40.6	42.1	219.8	
229.7	-	-	-	37.7	38.4	-	41.4	35.7	26.7	-	-	29.5	-	-	35.5	36.2	37.5	229.7	
232.9	-	-	-	36.4	37.0	-	40.3	35.4	26.5	-	-	28.4	-	-	34.2	34.8	36.2	232.9	
242.8	-	-	-	32.6	33.1	-	36.8	34.4	25.8	-	-	-	-	-	30.2	30.9	-	242.8	
252.6	-	-	-	29.1	-	-	33.3	33.2	25.3	-	-	-	-	-	26.9	27.4	-	252.6	
255.9	-	-	-	-	-	-	32.2	32.8	25.1	-	-	-	-	-	25.8	26.2	-	255.9	
259.2	-	-	-	-	-	-	31.1	31.7	24.9	-	-	-	-	-	24.8	25.1	-	259.2	
269.0	-	-	-	-	-	-	27.8	28.4	-	-	-	-	-	-	21.6	-	-	269.0	
272.3	-	-	-	-	-	-	26.8	27.4	-	-	-	-	-	-	-	-	-	272.3	
282.2	-	-	-	-	-	-	24.0	24.5	-	-	-	-	-	-	-	-	-	282.2	
292.0	-	-	-	-	-	-	21.4	-	-	-	-	-	-	-	-	-	-	292.0	
295.3	-	-	-	-	-	-	-	-	-	-	-	-	-	-	-	-	-	295.3	
298.6	-	-	-	-	-	-	-	-	-	-	-	-	-	-	-	-	-	298.6	
308.4	-	-	-	-	-	-	-	-	-	-	-	-	-	-	-	-	-	308.4	

99,200 lb
 187,400 lb
 275,600 lb
 363,800 lb
 408,000 lb
 452,000 lb

0 lb
 66,100 lb
 110,200 lb

Operation

SH+LF

+ 39.4-118.1 ft 27.6 ft 32.2 ft/s 360° ASME B30.5																	
236.2 ft 255.9 ft																	
SH+LF_1																	
39.4 ft			78.7 ft			118.1 ft			39.4 ft			78.7 ft			118.1 ft		
15°	20°	30°	15°	20°	30°	15°	20°	30°	15°	20°	30°	15°	20°	30°	15°	20°	30°
ft																	
1,000 lb																	
ft																	
42.7	368.2	-	-	-	-	-	-	-	-	-	-	-	-	-	-	-	42.7
45.9	357.1	269.0	-	-	-	-	-	-	-	363.8	-	-	-	-	-	-	45.9
49.2	342.8	262.4	-	-	-	-	-	-	-	340.6	266.8	-	-	-	-	-	49.2
52.5	328.5	255.7	165.3	-	-	-	-	-	-	317.5	260.1	-	-	-	-	-	52.5
55.8	309.7	249.1	162.6	178.6	-	-	-	-	-	299.8	253.5	164.2	-	-	-	-	55.8
59.1	291.0	242.5	159.8	173.1	-	-	-	-	-	282.2	246.9	160.9	175.3	-	-	-	59.1
62.3	275.6	237.0	157.1	168.1	129.0	-	-	-	-	266.8	241.4	158.2	170.9	-	-	-	62.3
65.6	260.1	231.5	154.3	163.1	125.7	-	-	-	-	251.3	235.9	155.4	166.4	127.9	-	-	65.6
68.9	246.9	227.1	151.6	158.7	122.9	-	108.7	-	-	238.1	231.5	153.2	162.0	125.1	-	-	68.9
72.2	233.7	222.7	148.8	154.3	120.2	-	105.8	-	-	224.9	227.1	151.0	157.6	122.4	-	106.0	72.2
75.5	222.1	217.7	146.6	149.9	117.4	77.2	103.1	-	-	215.0	217.2	148.8	153.2	119.6	-	103.5	75.5
78.7	210.5	212.7	144.4	145.5	114.6	75.8	100.3	79.8	-	205.0	207.2	146.6	148.8	116.8	76.3	101.0	78.7
82.0	201.2	203.4	142.2	142.2	112.4	74.6	97.9	78.2	-	195.7	197.3	144.4	145.5	114.6	75.1	98.5	82.0
85.3	191.8	194.0	140.0	138.9	110.2	73.4	95.5	76.5	-	186.3	187.4	142.2	142.2	112.4	73.9	96.1	85.3
91.9	174.2	176.4	136.7	132.3	105.8	71.0	91.1	73.2	-	169.8	172.0	138.9	135.6	107.8	71.7	91.9	91.9
98.4	157.6	159.8	132.3	125.7	101.6	68.8	87.1	70.3	46.1	155.4	156.5	134.5	129.0	103.8	69.4	88.2	98.4
101.7	150.5	152.4	130.6	123.2	99.8	67.8	85.3	69.1	45.4	148.5	149.6	132.8	126.5	102.0	68.5	86.4	101.7
111.5	129.0	130.1	125.7	115.7	94.4	64.8	79.8	65.3	43.2	127.9	129.0	127.9	119.0	96.6	65.7	81.1	111.5
124.7	107.6	108.7	110.2	106.7	88.0	61.3	73.4	60.4	40.6	106.0	107.4	109.6	110.2	90.2	62.4	75.0	124.7
137.8	90.2	91.3	93.0	98.1	82.5	58.4	67.9	56.4	38.4	88.8	89.7	91.7	96.8	84.7	59.3	69.4	137.8
150.9	75.6	76.7	78.5	83.8	77.6	55.6	62.8	52.7	36.4	73.9	75.0	76.9	82.2	79.8	56.7	64.6	150.9
164.0	63.5	64.4	65.7	71.7	73.4	53.1	58.9	49.6	34.4	61.7	62.6	64.2	70.1	71.9	54.2	60.4	164.0
177.2	53.1	54.0	55.1	61.1	62.6	51.1	55.6	47.0	32.8	51.4	52.2	53.6	59.5	61.1	52.0	56.9	177.2
190.3	44.5	45.2	46.3	52.0	53.4	49.2	52.7	44.5	31.5	42.8	43.4	44.5	50.3	51.8	50.3	54.0	190.3
203.4	37.3	37.7	38.6	44.3	45.4	47.6	49.6	42.3	30.2	35.3	35.9	36.8	42.5	43.9	46.3	48.1	203.4
210.0	34.1	34.5	35.1	40.9	42.0	44.1	46.2	41.3	29.5	32.1	32.6	33.5	39.0	40.3	42.7	44.5	210.0
216.5	30.9	31.3	-	37.5	38.6	40.6	42.8	40.3	28.9	28.9	29.3	30.2	35.9	37.0	39.0	41.0	216.5
223.1	28.1	28.4	-	34.6	35.6	37.3	39.7	39.2	28.4	26.0	26.5	27.3	33.0	34.0	35.7	37.9	223.1
229.7	25.4	25.6	-	31.7	32.6	34.2	36.6	38.1	28.0	23.4	23.8	-	30.0	30.9	32.6	34.8	229.7
236.2	22.9	23.1	-	29.1	30.0	31.4	34.0	35.3	27.4	20.9	21.3	-	27.3	28.2	29.9	32.2	236.2
242.8	20.5	-	-	26.5	27.3	28.7	31.3	32.6	26.9	18.5	18.7	-	24.7	25.6	27.1	29.5	242.8
246.1	19.4	-	-	25.2	26.1	27.3	30.1	31.4	26.7	17.4	17.6	-	23.5	24.3	25.9	28.3	246.1
249.3	18.3	-	-	24.0	24.8	-	28.9	30.1	26.6	16.3	16.5	-	22.4	23.1	24.6	27.1	249.3
252.6	-	-	-	22.9	23.6	-	27.7	28.8	26.4	15.2	15.4	-	21.2	21.9	23.4	25.9	252.6
255.9	-	-	-	21.8	22.5	-	26.5	27.6	26.2	14.1	-	-	20.1	20.7	22.0	24.7	255.9
262.5	-	-	-	19.7	20.4	-	24.3	25.4	25.6	12.2	-	-	18.0	18.6	19.8	22.5	262.5
265.7	-	-	-	18.7	19.3	-	23.1	24.3	25.2	11.2	-	-	16.9	17.6	-	21.4	265.7
269.0	-	-	-	17.6	18.3	-	22.0	23.1	24.9	-	-	-	15.9	16.5	-	20.3	269.0
275.6	-	-	-	15.9	16.3	-	20.2	21.1	22.7	-	-	-	14.0	14.6	-	18.4	275.6
282.2	-	-	-	14.1	-	-	18.3	19.2	20.7	-	-	-	12.1	12.8	-	16.5	282.2
285.4	-	-	-	13.2	-	-	17.4	18.2	19.6	-	-	-	11.3	11.9	-	15.7	285.4
292.0	-	-	-	-	-	-	15.7	16.4	-	-	-	-	9.6	10.1	-	13.9	292.0
295.3	-	-	-	-	-	-	14.8	15.4	-	-	-	-	8.8	-	-	13.0	295.3
298.6	-	-	-	-	-	-	13.9	14.6	-	-	-	-	8.2	-	-	12.2	298.6
308.4	-	-	-	-	-	-	11.5	12.1	-	-	-	-	-	-	-	9.7	308.4
311.7	-	-	-	-	-	-	10.7	11.2	-	-	-	-	-	-	-	8.9	311.7
315.0	-	-	-	-	-	-	10.0	-	-	-	-	-	-	-	-	8.2	315.0
318.2	-	-	-	-	-	-	9.3	-	-	-	-	-	-	-	-	8.2	318.2
321.5	-	-	-	-	-	-	8.6	-	-	-	-	-	-	-	-	-	321.5
324.8	-	-	-	-	-	-	7.9	-	-	-	-	-	-	-	-	-	324.8

99,200 lb 187,400 lb 275,600 lb 363,800 lb 408,000 lb 452,000 lb
 0 lb 66,100 lb 110,200 lb

Operation

SH+LF

+ 39.4-118.1 ft		27.6 ft		32.2 ft/s		360°		ASME B30.5									
275.6 ft						295.3 ft						315.0 ft					
SH+LF_1																	
39.4 ft			78.7 ft			118.1 ft			39.4 ft			78.7 ft			39.4 ft		
15°	20°	30°	15°	20°	30°	15°	20°	30°	15°	20°	30°	15°	20°	30°	15°	20°	30°
1,000 lb																	
ft																	ft
45.9	348.3	-	-	-	-	-	-	-	-	-	-	-	-	-	-	-	45.9
49.2	327.4	269.0	-	-	-	-	-	-	-	313.1	-	-	-	-	-	299.8	49.2
52.5	306.4	262.4	-	-	-	-	-	-	-	293.2	266.8	-	-	-	-	282.2	52.5
55.8	288.8	256.8	165.3	-	-	-	-	-	-	276.7	261.2	-	-	-	-	265.7	55.8
59.1	271.2	251.3	162.0	177.5	-	-	-	-	-	260.1	255.7	163.1	-	-	-	249.1	59.1
62.3	255.7	245.8	159.8	173.1	-	-	-	-	-	245.8	245.8	160.9	174.2	-	-	235.9	62.3
65.6	240.3	240.3	157.6	168.7	129.0	-	-	-	-	231.5	235.9	158.7	169.8	-	-	222.7	65.6
68.9	228.7	229.8	154.9	164.2	126.2	-	-	-	-	219.9	223.8	156.5	165.9	127.9	-	211.1	68.9
72.2	217.2	219.4	152.1	159.8	123.5	-	-	-	-	208.3	211.6	154.3	162.0	124.6	-	199.5	72.2
78.7	196.2	198.4	147.7	152.1	117.9	76.7	101.6	-	-	188.5	190.7	149.9	154.3	120.2	-	179.7	78.7
82.0	186.8	189.0	146.1	148.8	115.7	75.5	99.4	-	-	179.7	181.9	147.7	151.0	117.9	75.8	171.4	82.0
85.3	177.5	179.7	144.4	145.5	113.5	74.3	97.2	77.2	-	170.9	173.1	145.5	147.7	115.7	74.7	163.1	85.3
91.9	162.0	164.2	140.0	138.9	109.8	72.3	93.0	74.1	-	155.4	157.6	142.2	142.2	111.3	72.8	147.7	91.9
98.4	147.7	149.9	136.7	132.3	105.8	70.1	89.3	71.4	-	141.1	143.3	138.9	135.6	107.6	70.8	134.5	98.4
101.7	141.9	143.9	134.8	129.8	104.0	69.2	87.6	70.2	45.4	135.6	137.5	135.0	132.3	105.8	69.8	129.0	101.7
111.5	124.6	125.7	129.0	122.4	98.5	66.4	82.7	66.6	43.4	119.0	120.2	123.5	122.4	100.3	67.0	112.4	111.5
124.7	103.0	104.3	106.5	110.0	92.2	63.1	76.5	62.4	41.0	100.1	101.4	104.1	104.9	94.1	63.9	94.6	124.7
137.8	85.1	86.2	88.6	93.9	86.9	60.2	71.0	58.4	39.0	81.6	83.1	85.5	89.7	88.6	61.1	77.8	137.8
150.9	70.1	71.2	73.2	79.4	81.4	57.5	66.1	54.9	37.0	66.6	67.9	70.1	76.3	78.7	58.4	62.6	150.9
164.0	57.8	58.6	60.4	66.6	68.6	55.1	61.9	51.8	35.3	54.2	55.3	57.3	63.5	65.7	56.0	50.3	164.0
177.2	47.4	48.3	49.8	55.8	57.8	53.1	58.4	48.9	33.7	43.9	44.8	46.5	52.7	54.7	53.8	39.9	177.2
190.3	38.6	39.5	40.8	46.7	48.3	51.1	52.9	46.5	32.4	35.1	35.9	37.5	43.7	45.4	48.5	31.1	190.3
203.4	31.3	32.0	33.1	39.0	40.3	43.0	44.8	44.8	31.1	27.6	28.4	29.5	35.7	37.3	40.1	23.4	203.4
216.5	24.7	25.4	26.2	32.2	33.5	35.7	37.7	39.7	30.0	21.2	21.8	22.9	28.9	30.4	32.8	17.0	216.5
229.7	19.2	19.6	20.5	26.2	27.3	29.3	31.5	33.3	28.9	15.4	16.1	17.0	22.9	24.3	26.5	11.2	229.7
236.2	16.7	17.1	17.9	23.6	24.5	26.5	28.8	30.5	28.4	12.9	13.6	14.3	20.3	21.5	23.5	8.6	236.2
239.5	15.4	15.9	-	22.3	23.3	25.1	27.4	29.2	28.2	11.6	12.3	13.0	19.0	20.1	22.1	-	239.5
242.8	14.1	14.6	-	20.9	22.0	23.8	26.0	27.8	28.0	10.4	11.0	11.7	17.6	18.7	20.7	-	242.8
249.3	12.0	12.3	-	18.6	19.6	21.3	23.6	25.3	26.7	8.2	8.6	9.5	15.2	16.4	18.2	-	249.3
255.9	9.9	10.1	-	16.3	17.2	18.7	21.2	22.7	25.4	-	-	-	13.0	13.9	15.7	-	255.9
262.5	7.9	8.2	-	14.2	15.0	16.4	19.1	20.5	22.9	-	-	-	10.9	11.8	13.4	-	262.5
269.0	-	-	-	12.1	12.8	14.1	17.0	18.3	20.5	-	-	-	8.8	9.7	11.2	-	269.0
272.3	-	-	-	11.2	11.8	13.1	16.0	17.3	19.5	-	-	-	7.7	8.6	10.2	-	272.3
275.6	-	-	-	10.3	10.9	12.1	15.0	16.2	18.4	-	-	-	-	-	9.2	-	275.6
278.9	-	-	-	9.3	10.0	-	14.0	15.2	17.4	-	-	-	-	-	8.2	-	278.9
282.2	-	-	-	8.4	9.0	-	13.0	14.1	16.3	-	-	-	-	-	-	-	282.2
285.4	-	-	-	-	8.2	-	12.1	13.2	15.3	-	-	-	-	-	-	-	285.4
295.3	-	-	-	-	-	-	9.5	10.6	12.3	-	-	-	-	-	-	-	295.3
301.8	-	-	-	-	-	-	7.7	8.8	10.5	-	-	-	-	-	-	-	301.8
305.1	-	-	-	-	-	-	7.9	9.5	11.1	-	-	-	-	-	-	-	305.1
308.4	-	-	-	-	-	-	-	8.6	10.2	-	-	-	-	-	-	-	308.4
311.7	-	-	-	-	-	-	-	7.9	9.5	-	-	-	-	-	-	-	311.7

	99,200 lb	187,400 lb	275,600 lb	363,800 lb	408,000 lb	452,000 lb
	0 lb		66,100 lb		110,200 lb	

Operation

LH+LF

39.4 ft 27.6 ft 32.2 ft/s 360° ASME B30.5																			
157.5 ft 177.2 ft 196.9 ft 216.5 ft 236.2 ft 246.1 ft																			
LH+LF_1										LH+LF_3									
39.4 ft																			
15° 20° 30° 15° 20° 30° 15° 20° 30° 15° 20° 30° 15° 20° 30°																			
ft																			
1,000 lb																			
32.8	392.4	-	-	-	-	-	-	-	-	-	-	-	-	-	-	-	-	-	-
36.1	374.8	291.0	-	385.8	-	-	392.4	-	-	-	-	-	-	-	-	-	-	-	-
39.4	357.1	280.0	-	368.2	286.6	-	379.2	291.0	-	370.4	-	-	352.7	-	-	341.7	-	339.5	-
42.7	342.8	270.1	180.8	353.8	276.7	183.0	364.9	282.2	-	359.4	286.6	-	342.8	291.0	-	328.5	251.3	334.0	-
45.9	328.5	260.1	176.4	339.5	266.8	178.6	350.5	273.4	180.8	348.3	277.8	181.9	332.9	282.2	-	328.5	244.7	328.5	246.9
49.2	316.4	252.4	172.0	327.4	259.0	174.7	338.4	265.7	176.9	337.3	271.2	178.6	324.1	275.6	179.7	319.7	239.2	321.9	240.3
52.5	304.2	244.7	167.6	315.3	251.3	170.9	326.3	257.9	173.1	326.3	264.6	175.3	315.3	269.0	176.4	310.9	233.7	315.3	233.7
59.1	282.2	229.3	159.8	295.4	238.1	163.1	306.4	244.7	166.4	308.6	251.3	168.7	297.6	255.7	170.9	293.2	222.7	291.0	224.9
65.6	264.6	218.3	153.2	277.8	224.9	156.5	286.6	231.5	159.8	275.6	238.1	162.0	266.8	244.7	164.2	266.8	212.7	262.4	215.0
72.2	249.1	207.2	147.7	260.1	215.0	151.0	257.9	220.5	154.3	249.1	227.1	156.5	240.3	233.7	159.8	240.3	202.8	235.9	205.0
78.7	233.7	196.2	142.2	235.9	205.0	145.5	233.7	211.6	148.8	224.9	218.3	152.1	219.4	220.5	154.3	218.3	195.1	213.8	197.3
85.3	213.8	187.4	136.7	211.6	195.1	141.1	209.4	202.8	144.4	206.1	208.3	146.6	199.5	201.7	149.9	199.5	187.4	195.1	189.6
91.9	192.9	179.7	132.3	190.7	187.4	135.6	188.5	189.6	140.0	185.2	186.3	142.2	183.0	185.2	145.5	183.0	180.8	179.7	180.8
98.4	175.3	172.0	127.9	173.1	174.2	132.3	169.8	170.9	135.6	167.6	168.7	138.9	165.3	166.4	141.1	165.3	166.4	164.2	165.3
111.5	146.6	147.7	120.2	144.4	145.5	124.6	141.1	142.2	127.9	138.9	140.0	131.2	136.7	137.8	134.5	136.7	137.8	134.5	136.7
124.7	125.7	125.7	114.6	122.4	123.5	117.9	120.2	120.2	122.4	116.8	117.9	119.0	114.6	115.7	116.8	114.6	115.7	113.5	113.5
137.8	108.9	109.3	110.0	106.0	106.7	107.6	103.2	103.8	104.9	100.1	101.0	102.1	98.1	98.8	100.3	97.7	98.5	96.1	97.0
150.9	95.2	95.5	96.1	92.4	92.8	93.5	89.3	89.9	90.8	86.2	86.9	88.0	84.2	84.9	86.0	83.8	84.7	82.2	82.9
154.2	92.4	92.6	93.0	89.6	89.9	90.6	86.4	87.0	87.9	83.4	84.0	84.9	81.4	82.0	83.1	80.9	81.7	79.3	80.0
164.0	84.0	84.2	-	81.1	81.4	82.0	78.0	78.5	79.4	75.0	75.4	76.3	72.8	73.2	74.3	72.3	73.0	70.3	71.2
167.3	81.7	81.9	-	78.7	78.9	79.4	75.7	76.1	76.9	72.5	73.0	73.9	70.2	70.7	71.8	69.8	70.4	67.8	68.6
173.9	77.1	77.2	-	74.0	74.3	-	70.9	71.4	72.1	67.7	68.1	69.0	65.1	65.6	66.7	64.7	65.4	62.7	63.4
177.2	74.7	-	-	71.7	72.1	-	68.6	69.0	69.7	65.3	65.7	66.6	62.6	63.1	64.2	62.2	62.8	60.2	60.8
180.4	72.8	-	-	69.7	70.0	-	66.5	67.0	67.5	63.1	63.5	64.4	60.3	60.8	61.9	60.0	60.5	58.0	58.6
183.7	-	-	-	67.7	68.0	-	64.5	64.9	65.3	61.0	61.4	62.2	58.0	58.6	59.6	57.8	58.2	55.9	56.4
187.0	-	-	-	65.7	65.9	-	62.4	62.9	-	58.8	59.2	60.0	56.0	56.5	57.3	55.7	56.1	53.7	54.2
190.3	-	-	-	63.7	-	-	60.4	60.8	-	56.7	57.1	57.8	54.0	54.5	55.3	53.6	54.0	51.6	52.0
196.9	-	-	-	60.4	-	-	56.8	57.2	-	53.0	53.3	53.8	50.3	50.7	51.5	49.8	50.3	47.8	48.3
203.4	-	-	-	-	-	-	53.1	53.6	-	49.4	49.6	-	46.5	47.0	47.6	46.1	46.5	44.1	44.5
210.0	-	-	-	-	-	-	50.0	-	-	46.2	46.4	-	43.3	43.8	44.3	43.0	43.3	40.9	41.3
213.3	-	-	-	-	-	-	48.5	-	-	44.6	44.8	-	41.7	42.2	-	41.4	41.7	39.2	39.7
216.5	-	-	-	-	-	-	-	-	-	43.0	43.2	-	40.1	40.6	-	39.9	40.1	37.7	38.1
219.8	-	-	-	-	-	-	-	-	-	41.6	41.9	-	38.7	39.1	-	38.5	38.7	36.3	36.7
229.7	-	-	-	-	-	-	-	-	-	37.5	-	-	34.6	35.1	-	34.4	34.6	32.2	32.4
232.9	-	-	-	-	-	-	-	-	-	36.4	-	-	33.5	33.7	-	33.2	33.4	31.0	31.2
236.2	-	-	-	-	-	-	-	-	-	-	-	-	32.3	32.4	-	32.0	32.2	29.8	30.0
242.8	-	-	-	-	-	-	-	-	-	-	-	-	30.0	-	-	29.5	-	27.3	27.6
249.3	-	-	-	-	-	-	-	-	-	-	-	-	27.8	-	-	27.3	-	25.2	-
255.9	-	-	-	-	-	-	-	-	-	-	-	-	-	-	-	-	-	23.1	-

Operation

LH+LF

+ 39.4 ft 27.6 ft 32.2 ft/s 360° ASME B30.5																			
255.9 ft					265.8 ft					275.6 ft					285.5 ft				
LH+LF_1					LH+LF_3					LH+LF_1					LH+LF_3				
LH+LF_4					LH+LF_3					LH+LF_4					LH+LF_3				
39.4 ft																			
15°		20°		30°		15°		20°		15°		20°		15°		20°		15°	
1,000 lb																			
ft																			ft
42.7	319.7	-	-	348.3	-	350.5	-	302.0	-	-	339.5	-	385.8	-	-	-	-	-	42.7
45.9	310.9	275.6	-	337.3	249.1	341.7	249.1	297.6	273.4	-	332.9	251.3	370.4	-	321.9	-	361.6	-	45.9
49.2	302.0	269.0	-	327.4	242.5	330.7	243.6	294.3	271.2	-	323.0	245.8	354.9	302.0	314.2	246.9	348.3	302.0	49.2
52.5	293.2	262.4	178.6	317.5	235.9	319.7	238.1	291.0	269.0	179.7	313.1	240.3	341.7	295.4	306.4	240.3	335.1	295.4	52.5
59.1	277.8	249.1	172.0	288.8	224.9	284.4	227.1	275.6	262.4	174.2	280.0	229.3	308.6	282.2	273.4	231.5	304.2	284.4	59.1
65.6	255.7	238.1	166.4	260.1	217.2	253.5	218.3	249.1	251.3	168.7	249.1	220.5	275.6	271.2	244.7	222.7	271.2	273.4	65.6
72.2	231.5	227.1	160.9	233.7	207.2	229.3	209.4	224.9	227.1	163.1	224.9	211.6	246.9	251.3	220.5	213.8	242.5	244.7	72.2
78.7	210.5	212.7	156.5	213.8	199.5	208.3	201.7	205.0	207.2	158.7	206.1	203.9	224.9	227.1	200.6	202.8	220.5	222.7	78.7
85.3	191.8	194.0	152.1	195.1	191.8	190.7	192.9	187.4	188.5	154.3	187.4	189.6	203.9	206.1	183.0	185.2	199.5	201.7	85.3
91.9	176.4	177.5	147.7	179.7	180.8	175.3	176.4	170.9	173.1	149.9	172.0	174.2	186.3	188.5	167.6	169.8	181.9	184.1	91.9
98.4	162.0	163.1	144.4	165.3	166.4	160.9	162.0	157.6	158.7	146.6	158.7	159.8	169.8	172.0	154.3	155.4	166.4	168.7	98.4
111.5	133.4	134.5	136.7	136.7	137.8	134.5	135.6	133.4	134.5	136.7	133.4	134.5	138.9	141.1	131.2	132.3	137.8	138.9	111.5
124.7	111.3	112.4	114.6	114.6	115.7	112.4	113.5	111.3	112.4	113.5	111.3	112.4	115.7	116.8	109.6	110.2	113.5	114.6	124.7
137.8	95.0	95.9	97.4	97.7	98.3	95.5	96.3	93.9	94.8	96.6	94.6	95.5	97.4	98.5	92.4	93.3	95.5	96.6	137.8
150.9	80.9	81.8	83.1	83.8	84.4	81.4	82.2	80.0	80.7	82.2	80.7	81.4	82.0	83.1	77.8	78.9	79.8	80.9	150.9
164.0	69.0	69.7	71.0	72.1	72.8	69.4	70.1	67.7	68.6	70.1	68.3	69.2	69.0	69.9	65.7	66.6	66.6	67.5	164.0
177.2	58.6	59.3	60.6	61.9	62.6	59.1	59.7	57.5	58.2	59.5	58.2	58.9	58.0	58.9	55.3	56.2	55.6	56.4	177.2
190.3	50.0	50.7	51.6	53.4	53.8	50.5	51.1	48.7	49.4	50.5	49.6	50.0	48.7	49.4	46.5	47.4	46.3	47.0	190.3
203.4	42.5	43.2	44.1	45.9	46.3	43.0	43.7	41.4	41.9	42.8	42.1	42.5	40.8	41.2	39.2	39.7	38.1	39.0	203.4
216.5	36.2	36.6	37.5	39.5	39.9	36.6	37.0	34.8	35.5	36.2	35.7	36.2	33.7	34.4	32.6	33.3	31.3	32.0	216.5
223.1	33.4	33.8	34.4	36.7	37.0	33.8	34.3	32.1	32.6	33.3	32.8	33.3	30.7	31.3	29.9	30.4	28.3	28.9	223.1
229.7	30.6	31.1	-	34.0	34.4	31.1	31.5	29.3	29.8	30.4	30.0	30.4	27.8	28.2	27.1	27.6	25.4	25.8	229.7
239.5	27.0	27.3	-	30.3	30.6	27.4	27.7	25.7	26.0	26.7	26.3	26.8	23.8	24.3	23.3	23.7	21.2	21.8	239.5
242.8	25.8	26.0	-	29.1	29.3	26.2	26.5	24.5	24.7	-	25.1	25.6	22.5	22.9	22.0	22.5	20.1	20.5	242.8
252.6	22.6	22.9	-	26.0	26.0	22.9	23.1	21.2	21.5	-	21.8	22.2	19.0	19.4	18.9	19.2	16.6	16.9	252.6
255.9	21.6	-	-	24.9	-	21.8	22.0	20.1	20.5	-	20.7	21.2	17.9	18.3	17.9	18.1	15.4	15.7	255.9
259.2	20.6	-	-	23.9	-	20.9	21.2	19.1	19.5	-	19.8	20.1	16.9	17.3	16.8	17.1	14.3	14.6	259.2
265.7	18.7	-	-	22.0	-	19.0	-	17.3	17.5	-	17.9	18.1	14.9	15.2	14.8	15.2	12.2	12.6	265.7
269.0	-	-	-	-	-	18.1	-	16.3	16.5	-	17.0	-	13.9	14.1	13.9	14.1	11.2	11.5	269.0
272.3	-	-	-	-	-	17.2	-	15.4	-	-	16.2	-	12.8	-	13.1	13.2	10.3	10.6	272.3
275.6	-	-	-	-	-	-	-	14.6	-	-	15.4	-	11.9	-	12.2	12.3	9.3	9.7	275.6
278.9	-	-	-	-	-	-	-	13.8	-	-	14.6	-	11.0	-	11.4	-	8.4	-	278.9
282.2	-	-	-	-	-	-	-	13.0	-	-	13.7	-	10.1	-	10.6	-	-	-	282.2
292.0	-	-	-	-	-	-	-	-	-	-	-	-	-	-	8.4	-	-	-	292.0

	99,200 lb	187,400 lb	275,600 lb	363,800 lb	408,000 lb	452,000 lb	496,100 lb
	0 lb			66,100 lb		110,200 lb	

Operation

LH+LF

39.4 ft 27.6 ft 32.2 ft/s 360° ASME B30.5																											
295.3 ft						305.1 ft						315.0 ft															
LH+LF_1			LH+LF_3			LH+LF_4			LH+LF_3			LH+LF_4			LH+LF_1			LH+LF_3			LH+LF_4						
39.4 ft																											
15°		20°		30°		15°		20°		15°		20°		15°		20°		15°		20°		30°		15°		20°	
ft																											
1,000 lb																											
ft																											
45.9	277.8	-	-	299.8	-	352.7	-	288.8	-	343.9	-	246.9	-	-	275.6	-	339.5	-	45.9								
49.2	274.5	249.1	-	295.4	249.1	339.5	304.2	284.4	249.1	330.7	304.2	243.6	224.9	-	271.2	251.3	328.5	-	49.2								
52.5	271.2	246.9	-	291.0	242.5	326.3	297.6	280.0	244.7	319.7	299.8	240.3	222.7	-	266.8	244.7	315.3	299.8	52.5								
55.8	265.7	243.6	177.5	280.0	238.1	315.3	291.0	272.3	239.2	308.6	293.2	238.1	219.9	178.6	262.4	240.3	304.2	293.2	55.8								
59.1	260.1	240.3	175.3	269.0	233.7	297.6	284.4	264.6	233.7	293.2	286.6	235.9	217.2	176.4	257.9	235.9	286.6	286.6	59.1								
65.6	240.3	233.7	169.8	242.5	222.7	266.8	269.0	235.9	224.9	260.1	264.6	229.3	211.6	170.9	233.7	227.1	255.7	260.1	65.6								
72.2	217.2	219.4	165.3	219.4	215.0	238.1	242.5	213.8	216.1	233.7	235.9	209.4	206.1	166.4	210.5	212.7	229.3	231.5	72.2								
78.7	197.3	198.4	160.9	199.5	201.7	216.1	219.4	194.0	196.2	211.6	213.8	190.7	192.9	162.0	191.8	194.0	207.2	210.5	78.7								
85.3	179.7	181.9	156.5	181.9	184.1	196.2	198.4	177.5	178.6	191.8	194.0	173.1	175.3	157.6	174.2	176.4	188.5	190.7	85.3								
91.9	164.2	166.4	152.1	166.4	168.7	178.6	180.8	162.0	164.2	175.3	177.5	158.7	160.9	154.3	159.8	162.0	170.9	174.2	91.9								
98.4	151.0	152.1	148.8	153.2	154.3	164.2	165.3	148.8	151.0	159.8	162.0	145.5	147.7	149.9	146.6	148.8	156.5	158.7	98.4								
111.5	127.9	130.1	132.3	131.2	132.3	135.6	137.8	126.8	127.9	134.5	135.6	123.5	124.6	127.9	124.6	125.7	131.2	133.4	111.5								
124.7	108.2	109.6	111.3	110.0	110.2	112.4	113.5	107.8	109.1	110.2	112.4	106.0	107.4	109.8	107.1	108.2	109.3	110.2	124.7								
137.8	90.8	91.9	93.7	92.8	93.7	94.1	95.5	90.4	91.5	91.9	93.3	89.1	89.9	91.9	89.7	90.8	89.9	91.5	137.8								
150.9	76.3	77.4	79.1	78.5	79.4	78.3	79.4	75.8	76.7	75.8	77.2	74.1	75.2	77.2	75.0	75.8	73.9	75.2	150.9								
164.0	63.9	65.0	66.6	66.1	67.0	65.0	65.9	63.5	64.4	62.6	63.7	61.7	62.6	64.4	62.6	63.5	60.6	61.7	164.0								
177.2	53.8	54.5	56.0	56.0	56.7	54.0	54.9	53.1	54.0	51.6	52.5	51.4	52.2	53.8	52.2	53.1	49.6	50.5	177.2								
190.3	45.0	45.6	47.0	47.2	47.8	44.5	45.4	44.3	45.0	42.1	43.0	42.5	43.4	44.8	43.4	44.1	40.1	41.0	190.3								
203.4	37.5	38.1	39.2	39.7	40.3	36.6	37.3	36.8	37.5	34.2	34.8	35.1	35.7	37.0	35.9	36.6	32.2	32.8	203.4								
216.5	31.1	31.5	32.6	33.3	33.7	29.8	30.2	30.4	30.9	27.1	27.8	28.7	29.1	30.2	29.3	30.0	25.1	25.8	216.5								
229.7	25.4	26.0	26.7	27.6	28.0	23.6	24.3	24.7	25.1	21.2	21.8	22.9	23.4	24.5	23.8	24.3	19.0	19.6	229.7								
242.8	20.5	20.9	21.6	22.7	23.1	18.3	18.7	19.8	20.3	15.9	16.3	17.9	18.5	19.2	18.7	19.2	13.7	14.3	242.8								
252.6	17.2	17.6	18.1	19.4	19.8	14.8	15.3	16.5	16.8	12.2	12.7	14.7	15.0	15.7	15.4	15.9	10.2	10.7	252.6								
255.9	16.1	16.5	-	18.3	18.7	13.7	14.1	15.4	15.7	11.0	11.5	13.7	13.9	14.8	14.3	14.8	9.0	9.5	255.9								
259.2	15.2	15.4	-	17.4	17.7	12.6	13.0	14.4	14.8	10.0	10.4	12.7	13.0	13.7	13.4	13.8	7.9	8.4	259.2								
265.7	13.3	13.5	-	15.5	15.8	10.5	10.9	12.5	12.9	7.9	8.4	10.7	11.1	11.7	11.5	11.8	-	-	265.7								
269.0	12.3	12.6	-	14.6	14.8	9.5	9.9	11.5	11.9	-	-	9.7	10.1	-	10.6	10.8	-	-	269.0								
272.3	11.5	11.7	-	13.7	13.9	8.6	8.9	10.6	11.0	-	-	8.8	9.1	-	9.7	9.9	-	-	272.3								
275.6	10.6	10.8	-	12.8	13.0	-	7.9	9.7	10.1	-	-	7.9	8.2	-	8.8	9.0	-	-	275.6								
278.9	9.7	9.9	-	11.9	12.1	-	-	8.8	9.3	-	-	-	-	-	7.9	8.2	-	-	278.9								
282.2	8.8	9.0	-	11.0	11.2	-	-	7.9	8.4	-	-	-	-	-	-	-	-	-	282.2								
285.4	8.2	8.4	-	10.3	-	-	-	-	-	-	-	-	-	-	-	-	-	-	285.4								
295.3	-	-	-	8.2	-	-	-	-	-	-	-	-	-	-	-	-	-	-	295.3								

Operation

LH+LF

+ 39.4 ft 27.6 ft 32.2 ft/s 360° ASME B30.5																
324.8 ft				334.6 ft				344.5 ft								
LH+LF_3		LH+LF_4		LH+LF_1		LH+LF_3		LH+LF_4		LH+LF_3		LH+LF_4				
39.4 ft																
15°		20°		15°		20°		15°		20°		15°		20°		
ft		1,000 lb												ft		
49.2	260.1	-	319.7	-	227.1	-	-	253.5	-	308.6	-	242.5	-	284.4	-	49.2
52.5	255.7	246.9	306.4	299.8	224.9	207.2	-	249.1	242.5	297.6	293.2	238.1	233.7	280.0	257.9	52.5
59.1	246.9	235.9	282.2	277.8	219.4	201.7	167.6	244.7	238.1	275.6	273.4	233.7	229.3	271.2	249.1	59.1
65.6	227.1	227.1	251.3	253.5	213.8	195.1	163.1	222.7	224.9	246.9	249.1	219.4	220.5	246.9	242.5	65.6
72.2	205.0	208.3	224.9	227.1	201.7	189.6	159.8	201.7	203.9	220.5	224.9	197.3	199.5	220.5	224.9	72.2
78.7	186.3	188.5	202.8	206.1	183.0	184.1	155.4	183.0	185.2	199.5	202.8	178.6	180.8	200.6	202.8	78.7
85.3	169.8	172.0	184.1	186.3	166.4	168.7	151.0	166.4	168.7	180.8	183.0	163.1	165.3	181.9	184.1	85.3
91.9	155.4	156.5	167.6	169.8	152.1	153.2	146.6	152.1	154.3	164.2	166.4	148.8	151.0	165.3	167.6	91.9
98.4	142.2	144.4	152.1	154.3	138.9	141.1	143.3	138.9	141.1	149.9	152.1	135.6	137.8	151.0	153.2	98.4
111.5	120.2	122.4	127.9	130.1	117.9	119.0	122.4	117.9	119.0	124.6	126.8	114.6	115.7	126.8	129.0	111.5
124.7	103.2	104.5	107.4	108.9	100.3	101.9	104.3	100.5	101.9	105.6	107.1	97.7	99.0	107.8	109.3	124.7
137.8	87.1	88.4	87.5	89.1	85.5	86.9	89.3	85.5	86.9	86.0	87.7	83.1	84.4	88.6	90.2	137.8
150.9	72.1	73.2	71.4	72.8	70.3	71.7	73.9	70.5	71.7	69.9	71.4	68.6	69.9	72.5	73.9	150.9
164.0	59.7	60.6	58.2	59.5	58.0	59.1	61.1	58.2	59.1	56.7	58.0	56.2	57.3	59.3	60.4	164.0
177.2	49.4	50.3	47.2	48.3	47.6	48.5	50.3	47.8	48.7	45.6	46.7	45.9	46.7	48.3	49.4	177.2
190.3	40.6	41.4	37.7	38.6	38.8	39.7	41.2	39.0	39.7	36.2	37.0	37.0	37.9	38.8	39.7	190.3
203.4	33.1	33.7	29.5	30.4	31.3	32.0	33.3	31.3	32.2	28.0	28.9	29.3	30.2	30.6	31.5	203.4
216.5	26.5	27.1	22.7	23.4	24.7	25.4	26.7	24.9	25.6	20.9	21.8	22.9	23.6	23.6	24.5	216.5
229.7	20.7	21.4	16.5	17.2	19.2	19.6	20.7	19.2	19.8	14.8	15.7	17.2	17.9	17.6	18.3	229.7
242.8	15.9	16.3	11.2	11.7	14.1	14.6	15.4	14.1	14.6	9.5	10.1	12.1	12.6	12.1	12.8	242.8
246.1	14.7	15.2	9.9	10.5	13.0	13.4	14.3	13.0	13.4	8.2	8.8	10.9	11.5	10.9	11.6	246.1
249.3	13.6	14.1	8.6	9.3	11.9	12.3	13.2	11.9	12.3	-	-	9.8	10.4	9.8	10.4	249.3
252.6	12.4	13.0	-	8.2	10.8	11.2	12.1	10.8	11.2	-	-	8.6	9.3	8.6	9.1	252.6
255.9	11.2	11.9	-	-	9.7	10.1	11.0	9.7	10.1	-	-	-	8.2	-	7.9	255.9
259.2	10.3	10.9	-	-	8.6	9.1	9.9	8.6	9.1	-	-	-	-	-	-	259.2
262.5	9.3	9.8	-	-	-	8.2	8.8	-	8.2	-	-	-	-	-	-	262.5
265.7	8.4	8.8	-	-	-	-	7.7	-	-	-	-	-	-	-	-	265.7
269.0	-	7.7	-	-	-	-	-	-	-	-	-	-	-	-	-	269.0

	99,200 lb	187,400 lb	275,600 lb	363,800 lb	408,000 lb	452,000 lb	496,100 lb
	0 lb			66,100 lb		110,200 lb	

Operation

LH+LF

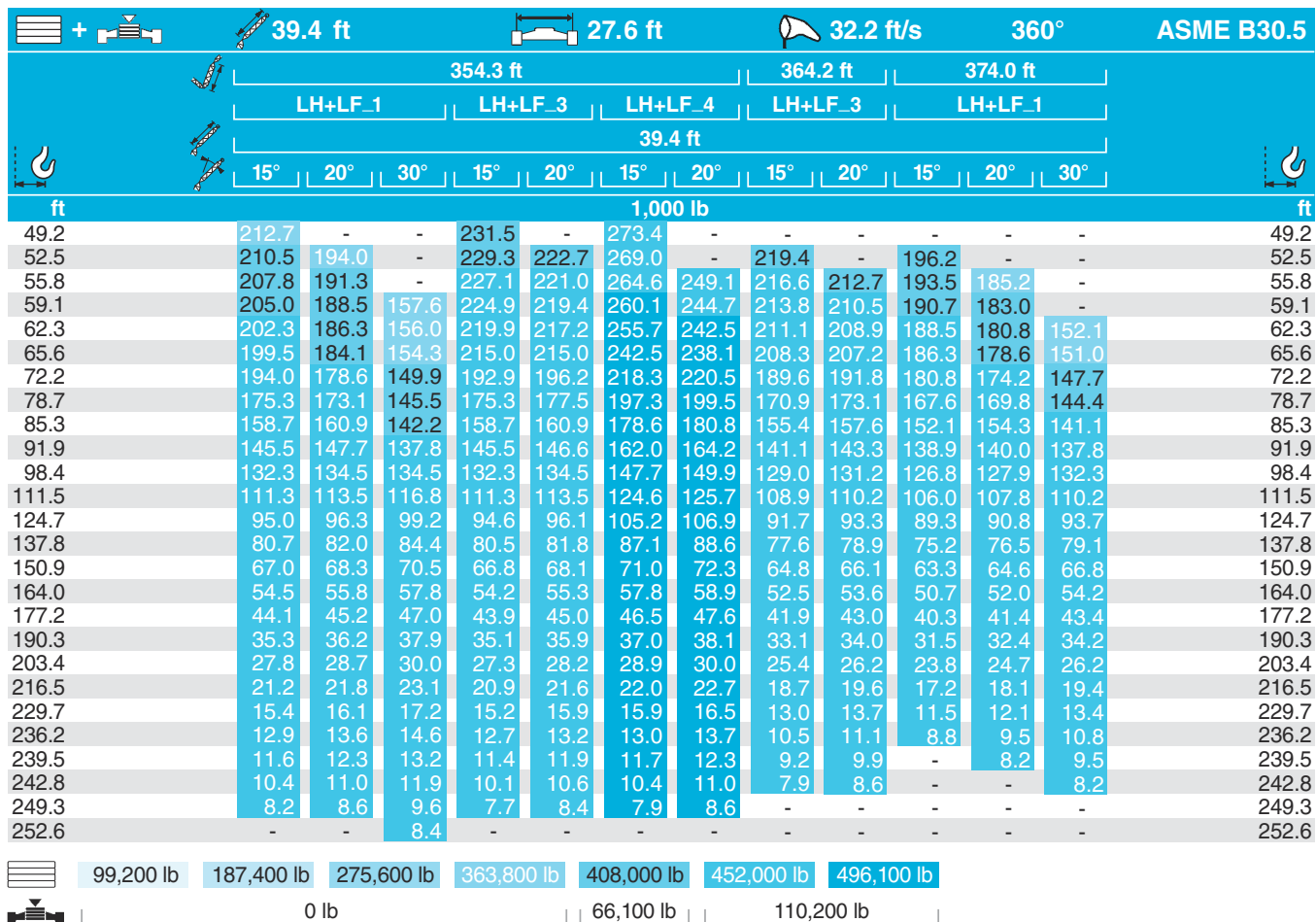

Operation

LH+LF

59.0 ft 27.6 ft 32.2 ft/s 360° ASME B30.5													
275.6 ft 285.5 ft 295.3 ft 305.1 ft 315.0 ft 324.8 ft LH+LF_4 59.0 ft 15° 20° 15° 20° 15° 20° 15° 20° 15° 20° 15° 20°													
ft	1,000 lb												ft
49.2	277.8	-	-	-	-	-	-	-	-	-	-	-	49.2
52.5	271.2	-	271.2	-	273.4	-	273.4	-	275.6	-	-	-	52.5
55.8	262.4	202.8	264.6	203.9	266.8	-	266.8	-	269.0	-	266.8	-	55.8
59.1	255.7	198.4	257.9	199.5	260.1	199.5	260.1	200.6	262.4	201.7	257.9	201.7	59.1
65.6	242.5	190.7	244.7	191.8	246.9	191.8	249.1	192.9	249.1	194.0	242.5	195.1	65.6
72.2	231.5	183.0	233.7	184.1	235.9	185.2	233.7	186.3	229.3	187.4	224.9	188.5	72.2
78.7	220.5	176.4	220.5	177.5	217.2	178.6	212.7	179.7	208.3	180.8	203.9	181.9	78.7
85.3	205.0	170.9	200.6	172.0	197.3	173.1	192.9	174.2	189.6	174.2	185.2	175.3	85.3
91.9	187.4	165.3	183.0	166.4	180.8	167.6	176.4	167.6	173.1	167.6	168.7	167.6	91.9
98.4	172.0	159.8	168.7	160.9	165.3	162.0	160.9	162.0	157.6	160.9	154.3	157.6	98.4
111.5	143.3	145.5	142.2	144.4	140.0	142.2	136.7	138.9	133.4	135.6	130.1	132.3	111.5
124.7	119.0	121.3	117.9	120.2	116.8	119.0	114.6	116.8	113.5	115.7	110.2	112.4	124.7
137.8	101.2	102.7	99.4	101.0	98.1	99.9	96.3	98.3	94.8	96.8	92.8	95.0	137.8
150.9	86.0	87.5	84.0	85.8	82.5	84.2	80.2	82.2	78.5	80.5	76.3	78.3	150.9
164.0	72.8	74.3	70.5	72.1	69.0	70.5	66.8	68.6	65.0	66.8	62.8	64.6	164.0
177.2	61.5	62.8	59.3	60.6	57.8	59.3	55.6	57.1	53.8	55.3	51.4	53.1	177.2
190.3	52.0	53.1	49.8	50.9	48.3	49.6	46.1	47.4	44.1	45.4	41.9	43.2	190.3
203.4	43.9	45.0	41.7	42.8	40.1	41.2	37.7	39.0	35.9	37.0	33.5	34.8	203.4
216.5	36.8	37.7	34.6	35.5	32.8	34.0	30.6	31.7	28.7	29.8	26.2	27.6	216.5
229.7	30.6	31.5	28.2	29.1	26.7	27.6	24.5	25.4	22.5	23.4	20.1	21.2	229.7
242.8	25.1	25.8	22.9	23.6	21.2	22.0	19.0	19.6	17.0	17.9	14.6	15.4	242.8
255.9	20.3	20.9	18.1	18.7	16.3	17.0	14.1	14.8	12.1	12.8	9.5	10.4	255.9
259.2	19.2	19.8	17.0	17.6	15.2	15.9	12.8	13.7	10.9	11.7	8.4	9.3	259.2
262.5	18.2	18.7	15.9	16.5	14.1	14.8	11.8	12.6	9.8	10.6	-	8.2	262.5
265.7	17.1	17.6	14.8	15.4	13.0	13.7	10.7	11.5	8.6	9.5	-	-	265.7
269.0	16.1	16.5	13.7	14.3	12.1	12.6	9.7	10.4	-	8.4	-	-	269.0
272.3	15.2	15.5	12.8	13.2	11.1	11.6	8.6	9.4	-	-	-	-	272.3
275.6	14.2	14.6	11.8	12.3	10.1	10.6	-	8.4	-	-	-	-	275.6
282.2	12.3	12.6	9.9	10.4	8.2	8.6	-	-	-	-	-	-	282.2
285.4	11.5	11.7	9.0	9.4	-	7.7	-	-	-	-	-	-	285.4
288.7	10.6	10.8	8.2	8.4	-	-	-	-	-	-	-	-	288.7
295.3	8.8	-	-	-	-	-	-	-	-	-	-	-	295.3
298.6	7.9	-	-	-	-	-	-	-	-	-	-	-	298.6

Operation

LH+LF

+ 78.7 ft		27.6 ft		32.2 ft/s		360°		ASME B30.5					
157.5 ft		177.2 ft		196.9 ft		216.5 ft		236.2 ft		255.9 ft			
LH+LF_1													
78.7 ft													
15°		20°		30°		15°		20°		30°			
15°		20°		30°		15°		20°		30°			
ft		1,000 lb										ft	
45.9	190.7	-	-	-	-	-	-	-	-	-	-	45.9	
49.2	183.5	-	-	187.4	-	-	190.7	-	-	-	-	49.2	
52.5	176.4	140.0	-	180.8	-	-	184.1	-	-	186.3	-	52.5	
55.8	169.8	135.6	-	174.2	137.8	-	178.0	140.0	-	180.8	-	55.8	
59.1	163.1	131.2	-	167.6	133.4	-	172.0	135.6	-	175.3	137.8	59.1	
62.3	157.6	127.3	-	162.6	130.1	-	167.0	132.3	-	170.3	134.5	62.3	
65.6	152.1	123.5	84.4	157.6	126.8	84.9	162.0	129.0	-	165.3	131.2	65.6	
68.9	147.2	120.2	82.7	152.7	123.5	83.2	157.1	125.7	83.8	160.9	127.9	68.9	
72.2	142.2	116.8	80.9	147.7	120.2	81.6	152.1	122.4	82.0	156.5	124.6	72.2	
78.7	134.5	110.2	77.6	138.9	113.5	78.5	143.3	116.8	79.1	147.7	119.0	78.7	
85.3	126.8	105.4	74.3	131.2	108.7	75.6	136.7	111.3	76.5	141.1	113.5	85.3	
91.9	120.2	100.3	71.4	124.6	103.6	73.0	129.0	106.7	73.9	133.4	109.3	91.9	
98.4	113.5	95.9	68.8	119.0	99.2	70.3	123.5	102.3	71.4	127.9	104.9	98.4	
111.5	103.6	88.0	64.2	108.5	91.3	65.7	112.4	94.4	67.2	116.8	97.2	111.5	
124.7	95.0	81.4	60.2	99.6	84.7	61.9	104.1	87.7	63.3	108.2	90.6	124.7	
137.8	87.7	75.8	56.9	92.2	78.9	58.4	96.3	82.0	60.0	100.5	84.9	137.8	
150.9	81.6	71.0	54.0	85.8	74.1	55.6	89.9	76.9	57.1	91.9	79.8	150.9	
164.0	76.3	66.8	51.6	80.2	69.9	53.1	83.1	72.8	54.5	80.2	75.4	164.0	
177.2	71.9	63.5	49.6	75.6	66.4	50.9	73.2	69.0	52.2	70.5	71.4	177.2	
190.3	67.9	60.6	48.1	67.7	63.1	49.2	65.0	65.7	50.5	62.2	63.1	190.3	
193.6	67.1	60.0	47.6	65.9	62.4	48.7	63.2	63.9	50.1	60.3	61.2	193.6	
203.4	63.1	58.2	-	60.6	60.4	47.8	57.8	58.4	48.9	54.7	55.6	203.4	
206.7	61.6	57.7	-	59.1	59.0	47.4	56.2	56.8	48.6	52.9	53.8	206.7	
210.0	60.1	57.1	-	57.5	57.7	-	54.6	55.2	48.3	51.1	52.0	210.0	
216.5	57.1	-	-	54.5	54.9	-	51.4	52.0	47.6	47.8	48.7	216.5	
219.8	-	-	-	53.0	53.4	-	49.8	50.5	47.4	46.4	47.2	219.8	
226.4	-	-	-	50.2	50.5	-	47.0	47.5	-	43.5	44.3	226.4	
229.7	-	-	-	48.7	-	-	45.6	46.1	-	42.1	42.8	229.7	
236.2	-	-	-	46.3	-	-	43.1	43.4	-	39.6	40.1	236.2	
242.8	-	-	-	-	-	-	40.6	40.8	-	37.0	37.5	242.8	
249.3	-	-	-	-	-	-	38.2	-	-	34.7	35.2	249.3	
252.6	-	-	-	-	-	-	37.0	-	-	33.5	34.0	252.6	
255.9	-	-	-	-	-	-	-	-	-	32.4	32.8	255.9	
259.2	-	-	-	-	-	-	-	-	-	31.4	31.7	259.2	
262.5	-	-	-	-	-	-	-	-	-	30.4	-	262.5	
269.0	-	-	-	-	-	-	-	-	-	28.4	-	269.0	
275.6	-	-	-	-	-	-	-	-	-	-	-	275.6	
282.2	-	-	-	-	-	-	-	-	-	-	-	282.2	
285.4	-	-	-	-	-	-	-	-	-	-	-	285.4	
292.0	-	-	-	-	-	-	-	-	-	-	-	292.0	
295.3	-	-	-	-	-	-	-	-	-	-	-	295.3	
301.8	-	-	-	-	-	-	-	-	-	-	-	301.8	

	99,200 lb	187,400 lb	275,600 lb	363,800 lb	408,000 lb	452,000 lb	496,100 lb
	0 lb			66,100 lb		110,200 lb	

Operation

LH+LF

+ 78.7 ft 27.6 ft 32.2 ft/s 360° ASME B30.5															
275.6 ft 295.3 ft 315.0 ft 334.6 ft 354.3 ft															
LH+LF_1															
78.7 ft															
15° 20° 30° 15° 20° 30° 15° 20° 30° 15° 20° 30° 15° 20° 30°															
ft 1,000 lb ft															
55.8	177.5	-	-	-	-	-	-	-	-	-	-	-	-	-	55.8
59.1	174.2	-	-	163.1	-	-	147.7	-	-	-	-	-	-	-	59.1
62.3	172.0	136.7	-	160.9	-	-	146.1	-	-	136.7	-	-	129.0	-	62.3
65.6	169.8	133.4	-	158.7	133.4	-	144.4	124.6	-	134.5	-	-	126.8	-	65.6
68.9	166.4	131.2	-	157.1	131.2	-	142.2	122.9	-	132.8	115.7	-	124.6	109.1	68.9
72.2	163.1	129.0	-	155.4	129.0	-	140.0	121.3	-	131.2	113.5	-	122.4	107.6	72.2
75.5	159.3	126.2	81.6	153.2	126.8	81.6	137.8	120.2	-	129.0	112.4	-	120.7	106.0	75.5
78.7	155.4	123.5	80.5	151.0	124.6	80.5	135.6	119.0	80.2	126.8	111.3	80.0	119.0	104.5	78.7
82.0	152.1	121.3	79.4	148.8	122.4	79.4	133.9	117.4	79.3	125.1	109.9	79.0	117.4	103.1	82.0
85.3	148.8	119.0	78.3	146.6	120.2	78.3	132.3	115.7	78.3	123.5	108.5	78.0	115.7	101.6	85.3
91.9	143.3	115.7	76.1	142.2	115.7	76.3	127.9	112.4	76.3	119.0	105.4	76.3	111.3	98.8	91.9
98.4	137.8	111.3	74.3	137.8	112.4	74.5	123.5	110.0	74.5	114.6	102.3	74.5	108.5	95.9	98.4
111.5	127.9	104.5	70.5	129.0	106.3	71.0	116.8	104.1	71.2	108.2	96.6	71.4	101.6	90.6	111.5
117.9	117.9	97.9	67.2	112.4	99.9	67.9	108.9	98.8	68.1	101.4	91.3	68.6	95.2	85.3	117.9
137.8	101.0	92.2	64.4	98.1	94.1	65.0	94.1	93.5	65.5	89.1	86.2	65.9	84.4	80.7	137.8
150.9	86.4	87.1	61.7	84.0	85.8	62.4	81.8	83.8	62.8	76.9	79.1	63.3	72.3	74.5	150.9
164.0	74.7	76.1	59.3	71.9	73.6	60.2	69.7	71.7	60.6	66.6	68.6	61.1	61.9	64.2	164.0
177.2	64.4	65.9	57.1	61.1	62.8	58.0	59.1	60.8	58.6	55.8	57.8	59.1	52.7	54.7	177.2
190.3	55.3	56.7	54.9	52.0	53.6	56.0	49.8	51.4	54.2	46.7	48.3	51.4	43.7	45.4	190.3
203.4	47.6	48.7	50.9	44.3	45.6	48.1	42.1	43.4	46.1	38.8	40.3	43.2	35.7	37.3	203.4
216.5	40.8	41.9	43.9	37.5	38.6	40.8	35.3	36.6	38.8	32.0	33.3	35.9	28.7	30.2	216.5
229.7	35.1	35.9	37.5	31.5	32.6	34.4	29.3	30.4	32.6	26.0	27.1	29.5	22.7	24.0	229.7
242.8	29.8	30.6	32.0	26.2	27.3	28.9	24.0	25.1	26.9	20.7	21.8	23.8	17.4	18.7	242.8
255.9	25.1	25.8	27.1	21.6	22.5	24.0	19.4	20.3	22.0	15.9	17.0	18.7	12.6	13.9	255.9
269.0	20.9	21.6	22.7	17.4	18.3	19.6	15.2	16.1	17.4	11.7	12.8	14.3	8.4	9.5	269.0
272.3	20.1	20.7	21.7	16.5	17.3	18.6	14.3	15.0	16.5	10.7	11.8	13.3	-	8.4	272.3
275.6	19.2	19.7	20.7	15.7	16.3	17.5	13.3	14.0	15.5	9.8	10.8	12.3	-	-	275.6
278.9	18.3	18.8	-	14.8	15.3	16.5	12.4	13.1	14.6	8.9	9.8	11.4	-	-	278.9
282.2	17.4	17.9	-	13.7	14.3	15.4	11.5	12.1	13.4	7.9	8.8	10.4	-	-	282.2
285.4	16.5	17.0	-	12.8	13.5	14.6	10.6	11.3	12.6	-	7.9	9.4	-	-	285.4
288.7	15.7	16.2	-	12.0	12.7	13.7	9.8	10.5	11.7	-	-	8.4	-	-	288.7
292.0	14.8	15.4	-	11.2	11.8	12.8	9.0	9.6	10.8	-	-	-	-	-	292.0
295.3	13.9	14.6	-	10.4	11.0	-	8.2	8.8	9.9	-	-	-	-	-	295.3
298.6	13.2	13.8	-	9.6	10.3	-	-	7.9	9.0	-	-	-	-	-	298.6
301.8	12.5	13.0	-	8.9	9.5	-	-	-	8.2	-	-	-	-	-	301.8
305.1	11.7	12.2	-	8.2	8.7	-	-	-	-	-	-	-	-	-	305.1
308.4	11.0	11.5	-	-	7.9	-	-	-	-	-	-	-	-	-	308.4
321.5	8.4	-	-	-	-	-	-	-	-	-	-	-	-	-	321.5

	99,200 lb	187,400 lb	275,600 lb	363,800 lb	408,000 lb	452,000 lb	496,100 lb
	0 lb			66,100 lb	110,200 lb		





Operation

LH+LF

+ 118.1 ft		27.6 ft		32.2 ft/s		360°		ASME B30.5					
157.5 ft		177.2 ft		196.9 ft		216.5 ft		236.2 ft		255.9 ft			
LH+LF_1													
118.1 ft													
15°		20°		30°		15°		20°		30°			
15°		20°		30°		15°		20°		30°			
ft		1,000 lb										ft	
59.1	117.9	-	-	-	-	-	-	-	-	-	-	59.1	
62.3	114.1	-	-	114.6	-	-	115.7	-	-	-	-	62.3	
65.6	110.2	-	-	111.3	-	-	112.4	-	-	112.4	-	65.6	
68.9	106.7	86.2	-	108.1	-	-	109.2	-	-	109.8	-	68.9	
72.2	103.2	83.8	-	104.9	84.4	-	106.0	85.1	-	107.1	-	72.2	
75.5	100.2	81.6	-	102.0	82.3	-	103.2	83.0	-	104.4	83.3	75.5	
78.7	97.2	79.4	-	99.0	80.2	-	100.3	80.9	-	101.6	81.4	78.7	
85.3	91.9	75.4	-	93.9	76.3	-	95.5	77.2	-	96.6	77.8	85.3	
88.6	89.5	73.6	49.2	91.5	74.6	49.2	93.1	75.5	-	94.5	76.2	88.6	
91.9	87.1	71.9	48.1	89.1	73.0	48.3	90.8	73.9	48.5	92.4	74.5	91.9	
95.1	84.8	70.1	47.1	86.9	71.3	47.4	88.7	72.3	47.6	90.3	73.1	95.1	
98.4	82.5	68.3	46.1	84.7	69.7	46.5	86.6	70.8	46.7	88.2	71.7	98.4	
111.5	74.3	62.4	42.8	76.7	63.9	43.2	78.9	65.0	43.7	80.7	66.1	111.5	
124.7	67.7	57.3	39.7	69.9	58.9	40.3	72.1	60.2	40.8	74.1	61.5	124.7	
137.8	62.4	52.9	37.3	64.4	54.5	37.9	66.6	56.0	38.4	68.6	57.1	137.8	
150.9	58.2	49.6	35.1	60.2	50.9	35.7	61.9	52.2	36.2	63.7	53.6	150.9	
164.0	54.2	46.5	33.1	56.4	48.1	33.7	58.2	49.4	34.4	59.7	50.5	164.0	
177.2	50.5	43.7	31.5	52.9	45.4	32.2	54.9	46.7	32.8	56.7	48.1	177.2	
190.3	47.4	41.2	30.0	49.6	42.8	30.6	51.8	44.3	31.3	53.6	45.4	190.3	
203.4	44.5	39.0	28.9	47.0	40.6	29.5	48.9	42.1	30.0	50.7	43.2	203.4	
216.5	42.1	37.0	27.8	44.3	38.8	28.4	46.3	40.1	28.9	48.1	41.2	216.5	
229.7	40.1	35.5	27.1	42.1	37.0	27.6	44.1	38.4	28.0	45.6	39.5	229.7	
242.8	38.4	34.2	-	40.1	35.5	26.9	42.1	36.8	27.3	43.3	37.9	242.8	
246.1	38.0	33.8	-	39.7	35.2	26.7	41.3	36.5	27.1	42.5	37.5	246.1	
249.3	37.6	33.5	-	39.2	34.9	-	40.5	36.2	27.0	41.8	37.1	249.3	
255.9	36.8	-	-	38.6	34.2	-	39.8	35.5	26.7	41.1	36.4	255.9	
259.2	-	-	-	38.2	34.0	-	39.4	35.2	26.5	40.7	36.1	259.2	
265.7	-	-	-	37.4	33.5	-	38.6	34.5	-	40.0	35.3	265.7	
269.0	-	-	-	37.0	-	-	38.2	34.2	-	39.6	35.0	269.0	
272.3	-	-	-	36.6	-	-	37.8	33.4	-	39.2	34.7	272.3	
282.2	-	-	-	-	-	-	36.6	31.1	-	37.6	32.2	282.2	
285.4	-	-	-	-	-	-	29.8	-	-	26.7	27.3	285.4	
288.7	-	-	-	-	-	-	28.9	-	-	25.8	26.5	288.7	
295.3	-	-	-	-	-	-	-	-	-	24.0	24.7	295.3	
301.8	-	-	-	-	-	-	-	-	-	22.5	23.2	301.8	
308.4	-	-	-	-	-	-	-	-	-	20.9	21.6	308.4	
311.7	-	-	-	-	-	-	-	-	-	-	18.0	18.3	311.7
321.5	-	-	-	-	-	-	-	-	-	-	15.7	-	321.5
324.8	-	-	-	-	-	-	-	-	-	-	15.0	-	324.8
328.1	-	-	-	-	-	-	-	-	-	-	-	-	328.1
334.6	-	-	-	-	-	-	-	-	-	-	-	-	334.6
341.2	-	-	-	-	-	-	-	-	-	-	-	-	341.2

	99,200 lb	187,400 lb	275,600 lb	363,800 lb	408,000 lb	452,000 lb	496,100 lb
	0 lb			66,100 lb		110,200 lb	

Operation

  118.1 ft  27.6 ft  32.2 ft/s 360° ASME B30.5													
275.6 ft 295.3 ft 315.0 ft 334.6 ft													
LH+LF_1													
118.1 ft													
15° 20° 30° 15° 20° 30° 15° 20° 30° 15° 20° 30°													
ft	1,000 lb												ft
68.9	110.2	-	-	-	-	-	-	-	-	-	-	-	68.9
72.2	108.0	-	-	106.3	-	-	-	-	-	-	-	-	72.2
75.5	105.7	-	-	104.5	-	-	96.8	-	-	90.6	-	-	75.5
78.7	103.4	81.6	-	102.7	-	-	95.7	-	-	89.5	-	-	78.7
82.0	101.2	80.1	-	101.0	80.0	-	94.5	79.4	-	88.3	-	-	82.0
85.3	99.0	78.7	-	99.2	78.7	-	93.3	78.0	-	87.1	74.7	-	85.3
91.9	95.0	75.8	-	95.5	75.8	-	90.8	75.6	-	84.7	73.0	-	91.9
98.4	91.3	73.2	46.7	91.9	73.4	46.5	88.4	73.2	-	82.5	71.2	-	98.4
101.7	89.7	72.0	46.1	90.3	72.3	45.9	87.2	72.1	45.6	81.2	70.3	45.4	101.7
111.5	84.9	68.3	44.1	85.5	68.8	44.1	83.6	68.8	44.1	77.6	67.7	43.9	111.5
124.7	78.9	64.2	41.9	79.8	64.8	41.9	78.9	64.8	41.9	73.2	64.4	41.9	124.7
137.8	73.6	60.4	39.9	74.7	61.1	39.9	74.5	61.3	39.9	68.8	61.1	39.9	137.8
150.9	68.8	56.9	37.9	70.1	57.5	38.1	70.3	58.0	38.1	64.8	58.0	38.4	150.9
164.0	64.6	53.8	36.2	65.9	54.5	36.4	66.6	55.1	36.6	61.1	54.9	36.6	164.0
177.2	61.1	50.9	34.6	62.2	51.8	34.8	63.1	52.5	35.1	57.5	52.2	35.3	177.2
190.3	58.0	48.7	33.3	57.3	49.4	33.5	55.3	50.0	33.7	52.0	49.6	34.0	190.3
203.4	52.2	46.7	32.0	49.2	47.4	32.4	47.2	47.8	32.6	44.3	46.5	32.6	203.4
216.5	45.2	44.8	30.9	42.1	44.1	31.3	40.1	42.1	31.5	37.3	39.2	31.5	216.5
229.7	39.2	40.6	29.8	36.2	37.7	30.2	34.0	35.7	30.4	31.1	32.8	30.9	229.7
242.8	33.7	35.1	28.9	30.6	32.2	29.3	28.7	30.2	29.5	25.6	27.3	30.0	242.8
255.9	28.9	30.2	28.2	25.8	27.1	28.4	23.8	25.1	28.0	20.7	22.3	25.1	255.9
269.0	24.7	25.8	27.3	21.6	22.7	24.9	19.4	20.7	23.1	16.3	17.6	20.5	269.0
282.2	20.7	21.8	23.6	17.6	18.7	20.7	15.4	16.8	19.0	12.3	13.7	16.1	282.2
295.3	17.2	18.1	19.6	14.1	15.0	16.8	11.9	13.0	15.0	8.8	9.9	12.1	295.3
298.6	16.4	17.3	18.7	13.3	14.3	15.9	11.1	12.2	14.1	7.9	9.0	11.2	298.6
301.8	15.7	16.5	17.9	12.5	13.4	15.0	10.4	11.4	13.2	-	8.2	10.4	301.8
308.4	14.1	15.0	16.1	10.8	11.7	13.2	8.8	9.7	11.5	-	-	8.6	308.4
311.7	13.4	14.1	15.3	10.1	11.0	12.5	7.9	8.9	10.6	-	-	7.7	311.7
315.0	12.7	13.4	14.6	9.4	10.3	11.7	-	8.2	9.8	-	-	-	315.0
321.5	11.2	11.9	-	7.9	8.8	10.1	-	-	8.2	-	-	-	321.5
324.8	10.6	11.2	-	-	7.9	9.4	-	-	-	-	-	-	324.8
328.1	9.9	10.5	-	-	-	8.6	-	-	-	-	-	-	328.1
334.6	8.6	9.0	-	-	-	-	-	-	-	-	-	-	334.6
337.9	7.9	8.4	-	-	-	-	-	-	-	-	-	-	337.9
341.2	-	7.7	-	-	-	-	-	-	-	-	-	-	341.2

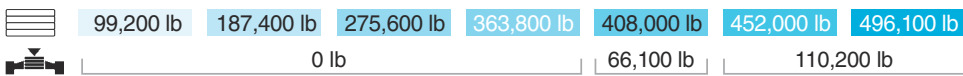

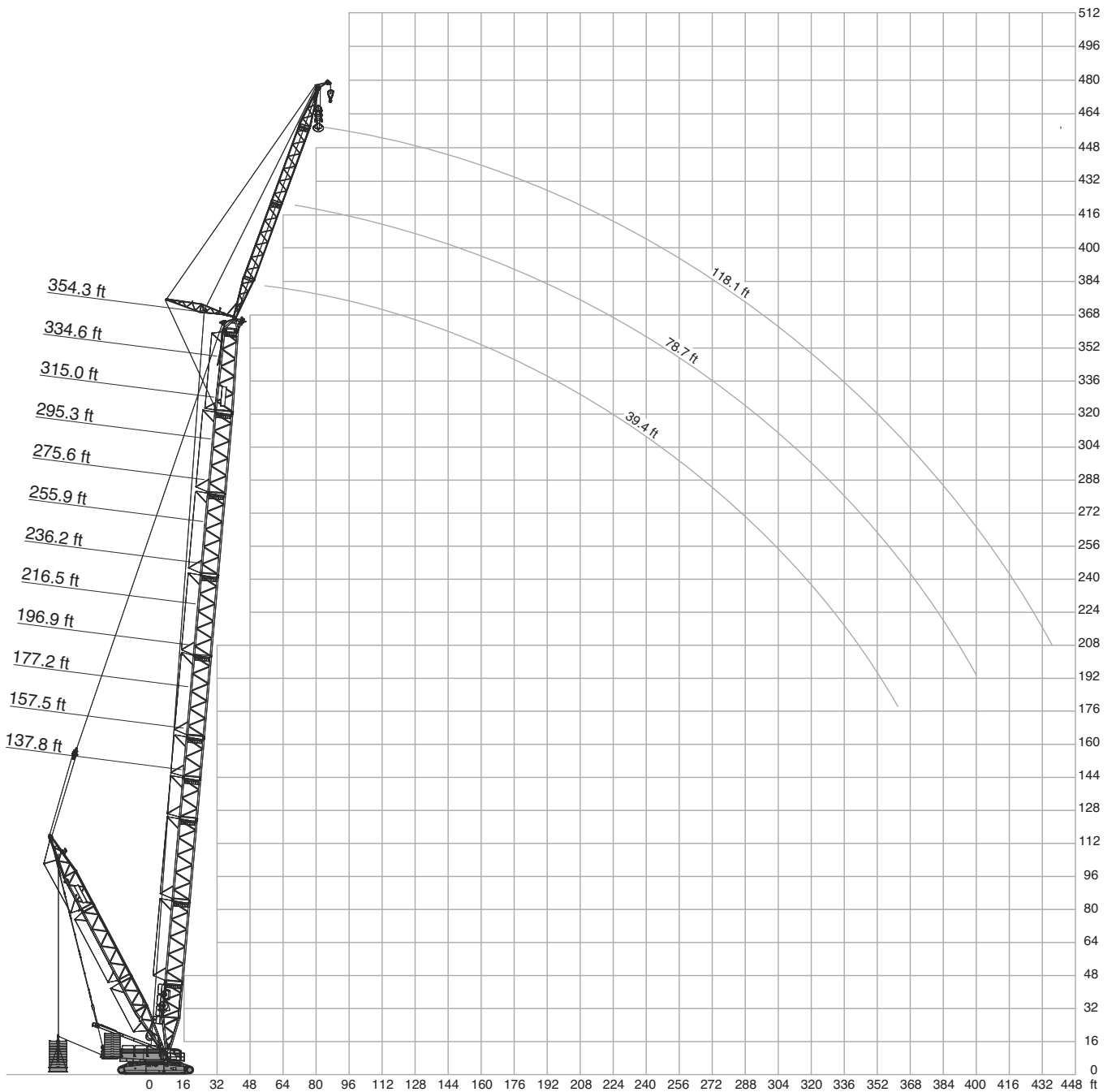

Operation

SSL+LF_1

363,800 lb +		110,200 lb		36.1-62.3 ft				27.6 ft		32.2 ft/s		360°		ASME B30.5	
137.8 ft															
SSL+LF_1															
39.4 ft				78.7 ft				118.1 ft							
0 lb-716.6 klb		0 lb-716.6 klb		0 lb-716.6 klb		0 lb-716.6 klb		0 lb-716.6 klb		0 lb-716.6 klb		0 lb-716.6 klb		0 lb-716.6 klb	
0 lb		0 lb		0 lb		0 lb		0 lb		0 lb		0 lb		0 lb	
15°		20°		30°		15°		20°		30°		15°		20°	
ft		1,000 lb													
36.1	357.1	357.1	-	-	-	-	-	-	-	-	-	-	-	-	-
39.4	339.5	339.5	264.6	264.6	-	-	-	-	-	-	-	-	-	-	-
42.7	324.1	324.1	254.6	254.6	168.7	168.7	-	-	-	-	-	-	-	-	-
45.9	308.6	308.6	244.7	244.7	164.2	164.2	-	-	-	-	-	-	-	-	-
49.2	295.4	295.4	235.9	235.9	159.8	159.8	174.2	174.2	-	-	-	-	-	-	-
52.5	282.2	282.2	227.1	227.1	155.4	155.4	166.4	166.4	-	-	-	-	-	-	-
55.8	272.3	272.3	219.9	219.9	151.6	151.6	159.8	159.8	127.9	127.9	-	-	-	-	-
59.1	262.4	262.4	212.7	212.7	147.7	147.7	153.2	153.2	123.5	123.5	-	-	-	-	-
62.3	252.4	252.4	206.7	206.7	144.4	144.4	147.7	147.7	119.6	119.6	-	-	110.2	111.3	-
65.6	242.5	242.5	200.6	200.6	141.1	141.1	142.2	142.2	115.7	115.7	79.1	79.1	106.7	107.1	-
72.2	227.1	227.1	189.6	189.6	135.6	135.6	132.3	132.3	108.7	108.7	75.2	75.2	99.4	99.6	81.6
78.7	213.8	213.8	179.7	179.7	130.1	130.1	123.5	123.5	102.5	102.5	71.7	71.7	93.0	93.5	76.5
85.3	201.7	201.7	170.9	170.9	124.6	124.6	116.8	116.8	97.0	97.0	68.6	68.6	87.3	87.7	72.1
88.6	196.2	196.2	166.4	166.4	122.4	122.4	113.4	113.4	94.6	94.6	67.1	67.1	84.8	85.1	70.1
91.9	190.7	190.7	162.0	162.0	120.2	120.2	110.0	110.0	92.2	92.2	65.7	65.7	82.2	82.5	68.1
98.4	173.1	181.9	155.4	155.4	116.8	116.8	104.1	104.1	87.7	87.7	63.1	63.1	77.4	77.6	64.6
111.5	146.6	165.7	140.7	143.7	110.4	110.4	94.4	94.4	80.4	80.4	58.8	58.8	69.6	69.7	58.6
124.7	124.4	152.1	124.6	133.7	104.9	104.9	85.9	85.9	73.9	73.9	55.0	55.0	62.9	62.9	53.3
137.8	106.5	141.1	106.9	125.7	100.5	100.5	78.7	78.7	68.3	68.3	51.6	51.6	57.3	57.3	48.7
144.4	100.0	137.1	100.4	122.7	94.6	98.8	75.9	75.9	66.2	66.2	50.3	50.3	55.0	55.0	47.0
150.9	93.5	133.0	93.8	119.8	-	-	73.1	73.1	64.1	64.1	49.1	49.1	52.8	52.8	45.2
157.5	87.1	129.0	87.3	116.8	-	-	70.3	70.3	61.9	61.9	47.8	47.8	50.5	50.5	43.4
164.0	81.8	125.7	-	-	-	-	68.2	68.2	60.3	60.3	46.9	46.9	48.7	48.7	42.0
177.2	-	-	-	-	-	-	63.9	63.9	56.9	56.9	45.0	45.0	45.2	45.2	39.2
180.4	-	-	-	-	-	-	63.1	63.1	56.3	56.3	44.8	44.8	44.5	44.5	38.7
190.3	-	-	-	-	-	-	60.7	60.7	54.5	54.5	-	-	42.3	42.3	36.9
196.9	-	-	-	-	-	-	59.1	59.1	53.4	53.4	-	-	40.8	40.8	35.7
203.4	-	-	-	-	-	-	58.0	58.0	-	-	-	-	39.7	39.7	34.8
216.5	-	-	-	-	-	-	-	-	-	-	-	-	37.5	37.5	33.1
219.8	-	-	-	-	-	-	-	-	-	-	-	-	37.0	37.0	32.7
229.7	-	-	-	-	-	-	-	-	-	-	-	-	35.7	35.7	31.7
236.2	-	-	-	-	-	-	-	-	-	-	-	-	34.8	34.8	31.1
239.5	-	-	-	-	-	-	-	-	-	-	-	-	34.4	34.4	-

	0 lb	143,300 lb	275,600 lb	363,800 lb	452,000 lb	584,300 lb	716,600 lb
--	------	------------	------------	------------	------------	------------	------------

Operation

SSL+LF_1

		363,800 lb + 110,200 lb		36.1-62.3 ft		27.6 ft		32.2 ft/s		360°		ASME B30.5	
		157.5 ft											
		SSL+LF_1											
		39.4 ft				78.7 ft				118.1 ft			
		0 lb-716.6 klb		0 lb-716.6 klb		0 lb-716.6 klb		0 lb-716.6 klb		0 lb-716.6 klb		0 lb-716.6 klb	
		0 lb		0 lb		0 lb		0 lb		0 lb		0 lb	
		15°		20°		30°		15°		20°		30°	
ft		1,000 lb											
36.1	368.2	368.2	-	-	-	-	-	-	-	-	-	-	-
39.4	350.5	350.5	269.0	269.0	-	-	-	-	-	-	-	-	-
45.9	319.7	319.7	251.3	251.3	166.4	166.4	-	-	-	-	-	-	-
49.2	307.5	307.5	242.5	242.5	162.6	162.6	178.6	178.6	-	-	-	-	-
52.5	295.4	295.4	233.7	233.7	158.7	158.7	172.0	172.0	-	-	-	-	-
55.8	284.4	284.4	227.1	227.1	154.9	154.9	165.3	165.3	130.1	130.1	-	-	-
59.1	273.4	273.4	220.5	220.5	151.0	151.0	158.7	158.7	125.7	125.7	-	-	-
62.3	264.6	264.6	214.4	214.4	147.7	147.7	153.2	153.2	121.8	121.8	-	-	-
65.6	255.7	255.7	208.3	208.3	144.4	144.4	147.7	147.7	117.9	117.9	-	-	-
68.9	248.0	248.0	202.8	202.8	141.6	141.6	142.7	142.7	114.6	114.6	78.0	78.0	104.8
72.2	240.3	240.3	197.3	197.3	138.9	138.9	137.8	137.8	111.3	111.3	76.3	76.3	101.2
78.7	224.9	224.9	187.4	187.4	133.4	133.4	129.0	129.0	105.8	105.8	73.0	73.0	95.0
85.3	209.4	213.8	178.6	178.6	129.0	129.0	121.3	121.3	100.3	100.3	69.9	69.9	89.7
91.9	188.5	202.8	170.9	170.9	124.6	124.6	114.6	114.6	95.5	95.5	67.2	67.2	84.7
98.4	169.8	192.9	163.1	163.1	120.2	120.2	109.3	109.3	91.1	91.1	64.6	64.6	80.0
111.5	143.3	176.7	141.8	151.4	113.5	113.5	99.5	99.5	83.7	83.7	60.3	60.3	72.2
124.7	121.2	162.8	122.1	141.1	108.0	108.0	90.8	90.8	77.2	77.2	56.5	56.5	65.5
137.8	103.4	151.0	104.1	132.3	103.6	103.6	83.3	83.3	71.7	71.7	53.1	53.1	59.7
150.9	90.3	141.5	90.8	125.7	91.1	100.2	77.5	77.5	67.1	67.1	50.6	50.6	55.3
157.5	83.8	136.7	84.2	122.4	84.9	98.5	74.5	74.5	64.8	64.8	49.4	49.4	53.1
164.0	78.9	133.4	79.1	119.7	-	-	72.2	72.2	63.1	63.1	48.4	48.4	51.3
173.9	71.5	128.4	71.4	115.7	-	-	68.8	68.8	60.6	60.6	46.8	46.8	48.5
177.2	69.0	126.8	-	-	-	-	67.7	67.7	59.7	59.7	46.3	46.3	47.6
180.4	67.0	125.7	-	-	-	-	66.7	66.8	59.1	59.1	45.9	45.9	46.9
190.3	-	-	-	-	-	-	63.9	64.2	57.1	57.1	44.9	44.9	44.7
193.6	-	-	-	-	-	-	62.9	63.3	56.4	56.4	44.5	44.5	43.9
203.4	-	-	-	-	-	-	58.7	61.1	54.7	54.7	-	-	42.0
213.3	-	-	-	-	-	-	53.9	59.1	53.1	53.1	-	-	40.1
216.5	-	-	-	-	-	-	52.2	58.4	-	-	-	-	39.5
219.8	-	-	-	-	-	-	50.7	58.0	-	-	-	-	39.0
229.7	-	-	-	-	-	-	-	-	-	-	-	-	37.6
232.9	-	-	-	-	-	-	-	-	-	-	-	-	37.1
242.8	-	-	-	-	-	-	-	-	-	-	-	-	35.9
249.3	-	-	-	-	-	-	-	-	-	-	-	-	35.1
255.9	-	-	-	-	-	-	-	-	-	-	-	-	34.4

	0 lb	143,300 lb	275,600 lb	363,800 lb	452,000 lb	584,300 lb	716,600 lb
--	------	------------	------------	------------	------------	------------	------------

Operation

SSL+LF_1

363,800 lb + 110,200 lb		36.1-62.3 ft		27.6 ft		32.2 ft/s		360°		ASME B30.5	
177.2 ft											
SSL+LF_1											
39.4 ft				78.7 ft				118.1 ft			
0 lb-716.6 klb		0 lb-716.6 klb		0 lb-716.6 klb		0 lb-716.6 klb		0 lb-716.6 klb		0 lb-716.6 klb	
0 lb		0 lb		0 lb		0 lb		0 lb		0 lb	
15°		20°		30°		15°		20°		30°	
ft	1,000 lb										
39.4	359.4	359.4	-	-	-	-	-	-	-	-	-
42.7	345.0	345.0	264.6	264.6	-	-	-	-	-	-	-
45.9	330.7	330.7	257.9	257.9	168.7	168.7	-	-	-	-	-
52.5	306.4	306.4	240.3	240.3	160.9	160.9	175.3	175.3	-	-	-
59.1	286.6	286.6	227.1	227.1	154.3	154.3	163.1	163.1	127.9	127.9	-
65.6	266.8	266.8	216.1	216.1	147.7	147.7	152.1	152.1	120.2	120.2	-
68.9	259.0	259.0	210.5	210.5	145.0	145.0	147.2	147.2	116.8	116.8	78.7
72.2	251.3	251.3	205.0	205.0	142.2	142.2	142.2	142.2	113.5	113.5	76.9
75.5	241.4	244.7	200.1	200.1	139.4	139.4	137.8	137.8	111.1	111.1	75.4
78.7	231.5	238.1	195.1	195.1	136.7	136.7	133.4	133.4	108.7	108.7	73.9
85.3	207.2	224.9	186.3	186.3	132.3	132.3	126.8	126.8	103.4	103.4	71.0
91.9	185.2	213.8	178.6	178.6	127.9	127.9	120.2	120.2	98.5	98.5	68.3
98.4	167.6	203.9	168.7	170.9	124.6	124.6	113.5	113.5	94.1	94.1	65.9
111.5	141.1	187.0	142.2	159.1	117.9	117.9	103.8	103.8	86.8	86.8	61.8
124.7	118.8	172.3	119.8	148.4	110.6	112.1	95.2	95.2	80.2	80.2	58.1
137.8	100.8	159.8	101.4	138.9	102.5	106.9	87.5	87.5	74.5	74.5	54.7
150.9	87.5	150.3	88.2	131.5	89.0	103.1	81.6	81.6	70.1	70.1	52.0
164.0	76.0	141.8	76.6	125.3	76.9	99.9	76.3	76.3	66.1	66.1	49.7
170.6	71.1	138.2	71.6	122.7	71.7	98.5	73.9	73.9	64.2	64.2	48.6
177.2	66.1	134.5	66.6	120.2	-	-	71.4	71.4	62.4	62.4	47.6
190.3	57.9	128.6	58.0	115.7	-	-	63.5	67.6	59.5	59.5	46.0
196.9	53.8	125.7	-	-	-	-	59.5	65.7	58.0	58.0	45.2
203.4	-	-	-	-	-	-	56.1	64.2	55.3	56.9	44.6
210.0	-	-	-	-	-	-	52.6	62.8	52.5	55.8	44.1
216.5	-	-	-	-	-	-	49.2	61.3	49.8	54.7	-
229.7	-	-	-	-	-	-	43.6	58.9	43.9	53.1	-
236.2	-	-	-	-	-	-	40.8	57.8	-	-	-
242.8	-	-	-	-	-	-	-	-	-	-	37.6
246.1	-	-	-	-	-	-	-	-	-	-	37.1
255.9	-	-	-	-	-	-	-	-	-	-	35.9
265.7	-	-	-	-	-	-	-	-	-	-	33.4
269.0	-	-	-	-	-	-	-	-	-	-	32.6
275.6	-	-	-	-	-	-	-	-	-	-	30.9

	0 lb	143,300 lb	275,600 lb	363,800 lb	452,000 lb	584,300 lb	716,600 lb
--	------	------------	------------	------------	------------	------------	------------

Operation

SSL+LF_1

363,800 lb + 110,200 lb		36.1-62.3 ft		27.6 ft		32.2 ft/s		360°		ASME B30.5	
196.9 ft											
SSL+LF_1											
39.4 ft				78.7 ft				118.1 ft			
0 lb-716.6 klb		0 lb-716.6 klb		0 lb-716.6 klb		0 lb-716.6 klb		0 lb-716.6 klb		0 lb-716.6 klb	
0 lb		0 lb		0 lb		0 lb		0 lb		0 lb	
15°		20°		30°		15°		20°		30°	
ft	1,000 lb										
39.4	368.2	368.2	-	-	-	-	-	-	-	-	-
42.7	354.9	354.9	271.2	271.2	-	-	-	-	-	-	-
45.9	341.7	341.7	262.4	262.4	-	-	-	-	-	-	-
49.2	329.6	329.6	254.6	254.6	166.4	166.4	-	-	-	-	-
52.5	317.5	317.5	246.9	246.9	162.0	162.0	178.6	178.6	-	-	-
59.1	295.4	295.4	233.7	233.7	156.5	156.5	166.4	166.4	130.1	130.1	-
65.6	277.8	277.8	220.5	220.5	149.9	149.9	155.4	155.4	122.4	122.4	-
72.2	249.1	262.4	211.6	211.6	144.4	144.4	146.6	146.6	116.8	116.8	77.6
75.5	237.0	254.6	206.7	206.7	142.2	142.2	142.2	142.2	113.5	113.5	76.1
78.7	224.9	246.9	201.7	201.7	140.0	140.0	137.8	137.8	110.2	110.2	74.5
85.3	203.9	235.9	192.9	192.9	135.6	135.6	131.2	131.2	105.8	105.8	71.9
91.9	183.0	222.7	184.1	185.2	131.2	131.2	124.6	124.6	101.2	101.2	69.4
95.1	173.6	218.3	175.3	181.3	129.0	129.0	121.3	121.3	99.1	99.1	68.2
98.4	164.2	213.8	166.4	177.5	126.8	126.8	117.9	117.9	97.0	97.0	67.0
111.5	137.8	196.9	139.3	165.7	120.2	120.2	108.2	108.2	89.7	89.7	62.9
124.7	115.5	181.9	116.5	155.1	111.0	114.6	99.5	99.5	83.1	83.1	59.2
137.8	97.4	168.7	98.1	145.5	99.4	110.0	91.7	91.7	77.4	77.4	56.0
150.9	84.2	158.4	84.9	137.4	85.9	105.9	85.5	85.5	72.8	72.8	53.4
164.0	72.4	149.2	73.0	130.4	73.9	102.4	77.7	80.0	68.6	68.6	51.0
177.2	61.9	141.1	62.4	124.6	63.3	99.4	68.3	75.0	64.8	64.8	48.9
183.7	57.8	137.8	58.3	122.4	58.6	98.1	64.2	73.0	62.1	63.3	48.1
190.3	53.7	134.5	54.2	120.2	-	-	60.0	71.0	59.4	61.9	47.2
203.4	46.4	129.0	46.5	116.5	-	-	52.3	67.4	53.1	59.2	45.7
206.7	44.8	127.9	44.8	115.7	-	-	50.6	66.6	51.4	58.5	45.4
216.5	39.9	124.6	-	-	-	-	45.4	64.2	46.1	56.7	44.5
223.1	-	-	-	-	-	-	42.6	62.8	43.2	55.7	43.9
229.7	-	-	-	-	-	-	39.8	61.5	40.3	54.7	-
242.8	-	-	-	-	-	-	34.7	59.2	35.0	53.2	-
246.1	-	-	-	-	-	-	33.5	58.7	33.7	52.9	-
252.6	-	-	-	-	-	-	31.1	57.8	-	-	-
255.9	-	-	-	-	-	-	-	-	-	-	-
262.5	-	-	-	-	-	-	-	-	-	-	-
269.0	-	-	-	-	-	-	-	-	-	-	-
282.2	-	-	-	-	-	-	-	-	-	-	-
292.0	-	-	-	-	-	-	-	-	-	-	-

	0 lb	143,300 lb	275,600 lb	363,800 lb	452,000 lb	584,300 lb	716,600 lb
--	------	------------	------------	------------	------------	------------	------------

Operation

SSL+LF_1

363,800 lb +		110,200 lb		36.1-62.3 ft		27.6 ft		32.2 ft/s		360°		ASME B30.5	
216.5 ft													
SSL+LF_1													
39.4 ft				78.7 ft				118.1 ft					
0 lb-716.6 klb		0 lb-716.6 klb		0 lb-716.6 klb		0 lb-716.6 klb		0 lb-716.6 klb		0 lb-716.6 klb		0 lb-716.6 klb	
0 lb		0 lb		0 lb		0 lb		0 lb		0 lb		0 lb	
15°		20°		30°		15°		20°		30°		15°	
20°		30°		15°		20°		30°		15°		20°	
30°		15°		20°		30°		15°		20°		30°	
1,000 lb													
42.7	361.6	361.6	-	-	-	-	-	-	-	-	-	-	-
45.9	348.3	348.3	266.8	266.8	-	-	-	-	-	-	-	-	-
52.5	326.3	326.3	251.3	251.3	164.2	164.2	-	-	-	-	-	-	-
55.8	313.1	316.4	244.7	244.7	160.9	160.9	175.3	175.3	-	-	-	-	-
59.1	299.8	306.4	238.1	238.1	157.6	157.6	169.8	169.8	-	-	-	-	-
62.3	283.3	296.5	232.6	232.6	154.9	154.9	164.8	164.8	127.9	127.9	-	-	-
65.6	266.8	286.6	227.1	227.1	152.1	152.1	159.8	159.8	124.6	124.6	-	-	-
68.9	253.5	278.9	222.1	222.1	149.9	149.9	154.9	154.9	121.3	121.3	-	-	-
72.2	240.3	271.2	217.2	217.2	147.7	147.7	149.9	149.9	117.9	117.9	-	-	-
75.5	229.3	264.6	212.2	212.2	145.0	145.0	146.1	146.1	115.2	115.2	76.7	76.7	108.2
78.7	218.3	257.9	207.2	207.2	142.2	142.2	142.2	142.2	112.4	112.4	75.2	75.2	99.4
85.3	198.4	244.7	199.5	199.5	137.8	137.8	134.5	134.5	108.2	108.2	72.8	72.8	94.4
91.9	180.8	233.7	183.0	190.7	133.4	133.4	127.9	127.9	103.6	103.6	70.3	70.3	89.9
98.4	163.1	222.7	164.2	184.1	130.1	130.1	122.4	122.4	99.4	99.4	67.9	67.9	85.8
111.5	136.0	205.8	137.1	171.6	123.5	123.5	112.4	112.4	92.2	92.2	63.9	63.9	78.6
124.7	113.4	190.7	114.4	160.6	112.7	117.6	103.4	103.4	85.8	85.8	60.4	60.4	71.9
137.8	95.5	177.5	96.3	151.0	97.9	112.4	95.5	95.5	80.0	80.0	57.3	57.3	65.9
150.9	82.2	166.4	83.0	142.9	84.2	108.5	86.5	89.1	75.3	75.3	54.7	54.7	61.4
164.0	70.3	156.5	70.9	136.0	71.9	104.9	76.9	83.5	71.1	71.1	52.2	52.2	57.5
177.2	59.5	147.7	60.2	130.1	61.1	101.6	66.6	78.5	67.2	67.2	50.0	50.0	54.2
190.3	51.3	141.1	51.8	124.9	52.5	99.1	57.9	74.2	58.9	64.2	48.3	48.3	51.1
200.1	45.5	136.5	46.0	121.4	46.5	97.4	51.8	71.2	52.9	61.9	47.1	47.1	48.9
203.4	43.9	135.2	44.3	120.5	-	-	50.1	70.4	51.1	61.3	46.7	46.7	48.3
216.5	37.3	130.1	37.7	116.8	-	-	43.2	67.0	44.1	58.6	45.4	45.4	45.6
223.1	34.6	127.9	34.8	114.6	-	-	40.3	65.6	41.2	57.6	42.4	44.9	43.4
229.7	32.0	125.7	-	-	-	-	37.5	64.2	38.2	56.6	39.4	44.4	41.1
232.9	30.6	124.6	-	-	-	-	36.0	63.5	36.7	56.1	37.9	44.1	39.9
236.2	-	-	-	-	-	-	34.6	62.8	35.3	55.6	36.4	43.9	38.8
242.8	-	-	-	-	-	-	32.3	61.7	32.8	54.8	-	-	36.4
255.9	-	-	-	-	-	-	27.6	59.5	28.0	53.4	-	-	31.5
262.5	-	-	-	-	-	-	25.6	58.6	26.0	52.7	-	-	29.4
269.0	-	-	-	-	-	-	23.6	57.8	-	-	-	-	27.3
275.6	-	-	-	-	-	-	-	-	-	-	-	-	25.1
282.2	-	-	-	-	-	-	-	-	-	-	-	-	23.4
295.3	-	-	-	-	-	-	-	-	-	-	-	-	19.8
298.6	-	-	-	-	-	-	-	-	-	-	-	-	19.1
308.4	-	-	-	-	-	-	-	-	-	-	-	-	16.8



Operation

SSL+LF_1

		363,800 lb + 110,200 lb		36.1-62.3 ft		27.6 ft		32.2 ft/s		360°		ASME B30.5	
		236.2 ft											
		SSL+LF_1											
		39.4 ft				78.7 ft				118.1 ft			
		0 lb-716.6 klb		0 lb-716.6 klb		0 lb-716.6 klb		0 lb-716.6 klb		0 lb-716.6 klb		0 lb-716.6 klb	
		0 lb		0 lb		0 lb		0 lb		0 lb		0 lb	
		15°		20°		30°		15°		20°		30°	
ft	1,000 lb												
42.7	368.2	368.2	-	-	-	-	-	-	-	-	-	-	-
45.9	357.1	357.1	269.0	269.0	-	-	-	-	-	-	-	-	-
52.5	326.3	332.9	255.7	255.7	165.3	165.3	-	-	-	-	-	-	-
55.8	307.5	323.0	249.1	249.1	162.6	162.6	178.6	178.6	-	-	-	-	-
59.1	288.8	313.1	242.5	242.5	159.8	159.8	173.1	173.1	-	-	-	-	-
62.3	273.4	304.2	237.0	237.0	157.1	157.1	168.1	168.1	129.0	129.0	-	-	-
65.6	257.9	295.4	231.5	231.5	154.3	154.3	163.1	163.1	125.7	125.7	-	-	-
68.9	244.7	287.7	227.1	227.1	151.6	151.6	158.7	158.7	122.9	122.9	-	-	-
72.2	231.5	280.0	222.7	222.7	148.8	148.8	154.3	154.3	120.2	120.2	-	-	-
75.5	220.5	273.4	217.2	217.2	146.6	146.6	149.9	149.9	117.4	117.4	77.2	77.2	103.5
78.7	209.4	266.8	211.6	212.7	144.4	144.4	145.5	145.5	114.6	114.6	75.8	75.8	100.8
85.3	190.7	253.5	192.9	205.0	140.0	140.0	138.9	138.9	110.2	110.2	73.4	73.4	95.7
91.9	174.2	242.5	175.3	196.2	136.7	136.7	132.3	132.3	105.8	105.8	71.0	71.0	91.3
98.4	158.7	231.5	160.9	189.6	132.3	132.3	125.7	125.7	101.6	101.6	68.8	68.8	87.3
111.5	132.3	213.8	133.7	177.1	125.7	125.7	115.4	115.4	94.6	94.6	65.0	65.0	80.2
124.7	110.1	198.4	111.1	166.1	113.2	119.8	106.6	106.6	88.2	88.2	61.5	61.5	73.8
137.8	92.2	185.2	93.0	156.5	94.8	114.6	99.2	99.2	82.5	82.5	58.4	58.4	67.9
150.9	78.3	174.2	79.2	148.4	80.8	110.8	85.8	92.7	77.7	77.7	55.8	55.8	63.2
164.0	66.1	164.2	66.9	141.1	68.3	107.2	73.8	86.9	71.7	73.5	53.4	53.4	59.1
177.2	55.6	155.4	56.2	134.5	57.3	103.8	63.1	81.8	64.4	69.7	51.1	51.1	55.6
190.3	47.2	148.1	47.7	129.3	48.6	101.0	54.4	77.4	55.6	66.4	49.4	49.4	52.8
203.4	39.7	141.5	40.1	124.6	40.9	98.7	46.5	73.4	47.6	63.4	46.4	47.8	49.0
213.3	34.7	137.1	35.2	121.3	35.7	97.2	41.2	70.8	42.3	61.3	43.4	46.7	45.5
216.5	33.1	135.6	33.5	120.2	-	-	39.5	69.9	40.6	60.6	42.3	46.3	44.3
229.7	27.6	130.4	28.1	117.2	-	-	33.7	66.8	34.7	58.4	36.2	45.1	38.4
239.5	23.8	127.0	24.0	114.6	-	-	29.7	64.7	30.5	56.9	31.7	44.3	34.2
242.8	22.7	126.2	-	-	-	-	28.5	64.1	29.3	56.4	30.4	44.1	33.0
249.3	20.5	124.6	-	-	-	-	26.2	62.9	26.9	55.6	27.8	43.7	30.5
252.6	-	-	-	-	-	-	25.0	62.3	25.7	55.1	24.0	43.4	29.2
255.9	-	-	-	-	-	-	23.8	61.7	24.5	54.7	-	-	28.0
269.0	-	-	-	-	-	-	19.7	59.7	20.4	53.4	-	-	23.9
278.9	-	-	-	-	-	-	16.8	58.3	17.2	52.5	-	-	20.9
282.2	-	-	-	-	-	-	16.0	58.0	-	-	-	-	20.0
288.7	-	-	-	-	-	-	14.3	57.3	-	-	-	-	18.2
295.3	-	-	-	-	-	-	-	-	-	-	-	-	16.3
308.4	-	-	-	-	-	-	-	-	-	-	-	-	13.2
315.0	-	-	-	-	-	-	-	-	-	-	-	-	11.7
321.5	-	-	-	-	-	-	-	-	-	-	-	-	10.2
324.8	-	-	-	-	-	-	-	-	-	-	-	-	9.5

	0 lb	143,300 lb	275,600 lb	363,800 lb	452,000 lb	584,300 lb	716,600 lb
--	------	------------	------------	------------	------------	------------	------------

Operation

SSL+LF_1

363,800 lb +		110,200 lb		36.1-62.3 ft		27.6 ft		32.2 ft/s		360°		ASME B30.5	
255.9 ft													
SSL+LF_1													
39.4 ft				78.7 ft				118.1 ft					
0 lb-716.6 klb		0 lb-716.6 klb		0 lb-716.6 klb		0 lb-716.6 klb		0 lb-716.6 klb		0 lb-716.6 klb		0 lb-716.6 klb	
0 lb		0 lb		0 lb		0 lb		0 lb		0 lb		0 lb	
15°		20°		30°		15°		20°		30°		15°	
20°		30°		15°		20°		30°		15°		20°	
30°		15°		20°		30°		15°		20°		30°	
1,000 lb													
45.9	359.4	363.8	-	-	-	-	-	-	-	-	-	-	-
49.2	337.3	352.7	266.8	266.8	-	-	-	-	-	-	-	-	-
52.5	315.3	341.7	260.1	260.1	-	-	-	-	-	-	-	-	-
55.8	297.6	331.8	253.5	253.5	164.2	164.2	-	-	-	-	-	-	-
59.1	280.0	321.9	246.9	246.9	160.9	160.9	176.4	176.4	-	-	-	-	-
65.6	249.1	304.2	235.9	235.9	155.4	155.4	166.4	166.4	127.9	127.9	-	-	-
72.2	224.9	288.8	227.1	227.1	151.0	151.0	157.6	157.6	122.4	122.4	-	-	-
78.7	202.8	273.4	205.0	218.3	146.6	146.6	148.8	148.8	116.8	116.8	76.3	76.3	101.2
82.0	194.0	267.9	195.7	213.8	144.4	144.4	145.5	145.5	114.6	114.6	75.1	75.1	98.9
85.3	185.2	262.4	186.3	209.4	142.2	142.2	142.2	142.2	112.4	112.4	73.9	73.9	96.6
91.9	168.7	249.1	170.9	201.7	138.9	138.9	135.6	135.6	107.8	107.8	71.7	71.7	92.2
98.4	154.3	240.3	156.5	195.1	134.5	134.5	129.0	129.0	103.8	103.8	69.4	69.4	88.4
101.7	148.3	235.9	150.3	192.0	132.3	133.0	126.6	126.6	102.1	102.1	68.5	68.5	86.7
111.5	130.1	222.7	131.5	182.6	125.7	128.6	119.4	119.4	96.8	96.8	65.8	65.8	81.5
124.7	108.9	206.5	109.9	171.2	112.0	122.7	109.2	110.6	90.4	90.4	62.4	62.4	75.2
137.8	90.8	191.8	91.7	160.9	93.5	116.8	98.3	102.5	84.7	84.7	59.3	59.3	69.4
150.9	76.9	180.8	77.7	152.9	79.4	113.2	84.7	96.0	80.0	80.0	56.7	56.7	64.7
164.0	64.5	170.5	65.3	145.5	66.8	109.6	72.3	90.2	72.7	75.6	54.2	54.2	60.6
177.2	53.8	160.9	54.5	138.9	55.8	106.0	61.3	84.9	62.8	71.7	52.0	52.0	57.1
190.3	45.4	153.6	45.9	133.7	47.1	103.1	52.6	80.5	54.0	68.4	50.3	50.3	54.3
203.4	37.8	147.0	38.4	128.6	39.3	100.5	44.8	76.4	46.0	65.4	48.6	48.6	49.5
216.5	31.1	141.1	31.7	123.5	32.4	98.3	37.7	72.5	38.8	62.6	40.8	47.2	42.8
226.4	27.1	136.7	27.6	121.3	28.0	97.0	33.4	70.2	34.4	60.8	36.2	46.2	38.3
229.7	25.8	135.2	26.2	120.5	-	-	32.0	69.4	32.9	60.3	34.6	45.9	36.7
242.8	20.9	130.4	21.2	117.6	-	-	26.7	66.6	27.6	58.1	29.0	44.8	31.3
255.9	16.3	126.8	16.8	114.6	-	-	22.0	63.9	22.7	56.2	24.0	43.9	26.5
265.7	13.4	124.6	-	-	-	-	19.0	62.3	19.6	55.1	20.5	43.2	23.3
269.0	-	-	-	-	-	-	17.9	61.7	18.6	54.7	-	-	22.2
282.2	-	-	-	-	-	-	14.2	59.8	14.8	53.4	-	-	18.2
295.3	-	-	-	-	-	-	10.8	58.2	10.6	52.2	-	-	14.6
305.1	-	-	-	-	-	-	8.6	57.1	-	-	-	-	12.2
308.4	-	-	-	-	-	-	-	-	-	-	-	-	11.5
321.5	-	-	-	-	-	-	-	-	-	-	-	-	8.5
324.8	-	-	-	-	-	-	-	-	-	-	-	-	7.7
331.4	-	-	-	-	-	-	-	-	-	-	-	-	34.4
334.6	-	-	-	-	-	-	-	-	-	-	-	-	34.2
341.2	-	-	-	-	-	-	-	-	-	-	-	-	33.7



Operation

SSL+LF_1

363,800 lb +		110,200 lb		36.1-62.3 ft		27.6 ft		32.2 ft/s		360°		ASME B30.5	
275.6 ft													
SSL+LF_1													
39.4 ft				78.7 ft				118.1 ft					
0 lb		0 lb-716.6 klb		0 lb-716.6 klb		0 lb-716.6 klb		0 lb-716.6 klb		0 lb-716.6 klb		0 lb-716.6 klb	
0 lb		0 lb		0 lb		0 lb		0 lb		0 lb		0 lb	
15°		20°		30°		15°		20°		30°		15°	
20°		30°		15°		20°		30°		15°		20°	
30°		15°		20°		30°		15°		20°		30°	
1,000 lb													
45.9	346.1	368.2	-	-	-	-	-	-	-	-	-	-	-
49.2	324.1	358.3	269.0	269.0	-	-	-	-	-	-	-	-	-
52.5	302.0	348.3	262.4	262.4	-	-	-	-	-	-	-	-	-
55.8	285.5	338.4	256.8	256.8	164.2	164.2	-	-	-	-	-	-	-
59.1	269.0	328.5	251.3	251.3	162.0	162.0	177.5	178.6	-	-	-	-	-
65.6	240.3	310.9	240.3	240.3	157.6	157.6	168.7	168.7	129.0	129.0	-	-	-
72.2	216.1	295.4	218.3	231.5	152.1	152.1	159.8	159.8	123.5	123.5	-	-	-
78.7	195.1	282.2	197.3	222.7	147.7	147.7	152.1	152.1	117.9	117.9	76.7	76.7	107.1
85.3	177.5	269.0	179.7	213.8	144.4	144.4	145.5	145.5	113.5	113.5	74.3	74.3	97.4
91.9	160.9	257.9	163.1	206.1	140.0	140.0	138.9	138.9	109.8	109.8	72.3	72.3	93.3
98.4	147.7	246.9	149.9	199.5	136.7	136.7	132.3	132.3	105.8	105.8	70.1	70.1	89.5
101.7	142.2	242.5	144.2	196.4	133.7	135.2	129.9	129.9	104.1	104.1	69.2	69.2	87.9
111.5	125.7	229.3	127.1	187.0	124.9	130.8	122.7	122.7	98.8	98.8	66.6	66.6	82.9
124.7	105.5	213.5	106.7	176.0	109.6	124.9	110.2	113.9	92.4	92.4	63.3	63.3	76.8
137.8	87.3	199.5	88.6	166.4	90.6	119.0	94.6	105.8	86.6	86.6	60.2	60.2	71.2
150.9	73.0	187.8	74.1	158.4	76.1	115.4	81.2	99.2	80.0	81.9	57.5	57.5	66.5
164.0	60.5	177.1	61.4	150.6	63.2	111.7	68.9	93.2	71.0	77.7	55.2	55.2	62.2
177.2	49.6	167.6	50.5	143.3	52.0	108.0	57.8	87.7	59.5	73.9	53.1	53.1	58.4
190.3	41.2	159.5	42.0	137.4	43.4	104.9	49.1	83.2	50.6	70.5	50.2	51.2	53.0
203.4	33.7	152.1	34.3	132.3	35.5	102.2	41.2	79.0	42.5	67.4	45.0	49.5	46.7
216.5	26.9	145.5	27.6	127.9	28.4	99.9	34.2	75.2	35.3	64.6	37.5	47.8	39.5
229.7	21.5	140.4	22.0	124.2	22.9	98.1	28.3	71.9	29.4	62.1	31.3	46.7	33.4
242.8	16.5	135.6	16.9	120.5	15.7	96.3	23.0	69.0	24.0	59.9	25.6	45.6	27.9
255.9	12.1	131.2	12.3	116.8	-	-	18.3	66.4	19.2	58.0	20.5	44.5	22.9
269.0	8.2	127.3	8.6	115.2	-	-	14.2	64.0	14.9	56.2	16.1	43.7	18.7
272.3	-	126.5	-	114.6	-	-	13.2	63.4	13.9	55.8	15.0	43.4	17.6
278.9	-	125.1	-	-	-	-	11.2	62.4	11.9	55.0	13.0	43.2	15.7
282.2	-	124.6	-	-	-	-	10.4	61.9	11.0	54.7	-	-	14.8
292.0	-	-	-	-	-	-	7.7	60.5	8.4	53.7	-	-	12.1
295.3	-	-	-	-	-	-	-	60.0	-	53.4	-	-	11.2
308.4	-	-	-	-	-	-	-	58.3	-	52.3	-	-	7.9
311.7	-	-	-	-	-	-	-	57.9	-	52.0	-	-	-
318.2	-	-	-	-	-	-	-	57.3	-	-	-	-	-
321.5	-	-	-	-	-	-	-	57.1	-	-	-	-	-
334.6	-	-	-	-	-	-	-	-	-	-	-	-	-
347.8	-	-	-	-	-	-	-	-	-	-	-	-	-
357.6	-	-	-	-	-	-	-	-	-	-	-	-	-

	0 lb	143,300 lb	275,600 lb	363,800 lb	452,000 lb	584,300 lb	716,600 lb
--	------	------------	------------	------------	------------	------------	------------

Operation





SSL+LF_1

		363,800 lb + 110,200 lb		36.1-62.3 ft		27.6 ft		32.2 ft/s		360°		ASME B30.5	
		295.3 ft											
		SSL+LF_1											
		39.4 ft				78.7 ft				118.1 ft			
		0 lb-716.6 klb		0 lb-716.6 klb		0 lb-716.6 klb		0 lb-716.6 klb		0 lb-716.6 klb		0 lb-716.6 klb	
		0 lb		0 lb		0 lb		0 lb		0 lb		0 lb	
		15°		20°		30°		15°		20°		30°	
ft		1,000 lb											
49.2	310.9	363.8	-	-	-	-	-	-	-	-	-	-	-
52.5	291.0	352.7	266.8	266.8	-	-	-	-	-	-	-	-	-
59.1	257.9	335.1	255.7	255.7	163.1	163.1	-	-	-	-	-	-	-
62.3	243.6	326.3	244.7	250.2	160.9	160.9	175.3	176.4	-	-	-	-	-
65.6	229.3	317.5	233.7	244.7	158.7	158.7	170.9	170.9	-	-	-	-	-
68.9	218.3	309.7	221.6	240.3	156.5	156.5	167.0	167.0	127.9	127.9	-	-	-
72.2	207.2	302.0	209.4	235.9	154.3	154.3	163.1	163.1	124.6	124.6	-	-	-
75.5	197.3	295.4	199.5	231.5	152.1	152.1	159.3	159.3	122.4	122.4	-	-	-
78.7	187.4	288.8	189.6	227.1	149.9	149.9	155.4	155.4	120.2	120.2	-	-	-
82.0	178.6	282.2	180.8	222.7	147.7	147.7	151.6	151.6	117.9	117.9	75.8	75.8	100.5
85.3	169.8	275.6	172.0	218.3	145.5	145.5	147.7	147.7	115.7	115.7	74.7	74.7	98.3
91.9	154.3	264.6	156.5	210.5	142.2	142.2	142.2	142.2	111.3	111.3	72.8	72.8	94.4
98.4	141.1	253.5	143.3	203.9	138.9	138.9	135.6	135.6	107.6	107.6	70.8	70.8	90.6
105.0	130.5	244.7	132.3	197.7	130.4	135.6	127.9	130.4	104.1	104.1	69.0	69.0	87.4
111.5	119.9	235.9	121.3	191.4	122.0	132.3	120.2	125.3	100.7	100.7	67.2	67.2	84.1
124.7	100.9	220.1	101.9	180.4	104.9	126.4	104.9	116.4	94.4	94.4	63.9	63.9	78.2
137.8	84.0	206.1	85.3	170.9	87.7	121.3	89.7	108.9	88.6	88.6	60.8	60.8	72.8
150.9	69.6	194.4	70.8	162.8	72.9	116.8	77.7	102.3	78.6	83.9	58.3	58.3	68.0
164.0	57.0	183.7	58.1	155.1	59.9	113.1	66.0	96.2	68.0	79.6	56.0	56.0	63.8
177.2	46.1	174.2	47.2	147.7	48.7	110.0	54.7	90.6	56.7	75.6	53.8	53.8	60.0
190.3	37.7	166.1	38.5	141.8	39.9	106.9	45.9	86.1	47.5	72.2	48.6	52.0	51.6
203.4	30.1	158.4	30.8	136.3	32.0	104.1	37.9	81.8	39.4	69.2	42.3	50.3	43.8
216.5	23.4	151.0	24.0	131.2	25.1	101.4	30.9	77.8	32.2	66.4	34.6	48.7	36.6
229.7	17.9	145.1	18.4	127.5	19.4	99.4	25.1	74.4	26.3	63.9	28.4	47.4	30.6
242.8	12.9	140.0	13.4	123.9	14.2	97.6	19.8	71.4	20.9	61.6	22.8	46.2	25.0
255.9	8.4	135.6	8.8	120.2	9.5	96.1	15.0	68.6	15.9	59.5	17.6	45.2	19.8
269.0	-	131.2	-	117.2	-	-	10.9	66.1	11.6	57.8	13.2	44.3	15.6
278.9	-	128.2	-	115.2	-	-	7.9	64.4	8.6	56.5	10.0	43.7	12.5
282.2	-	127.5	-	114.6	-	-	-	63.8	-	56.1	9.0	43.5	11.6
285.4	-	126.8	-	114.1	-	-	-	63.3	-	55.8	7.9	43.3	10.7
288.7	-	126.0	-	113.5	-	-	-	62.8	-	55.4	-	43.2	9.8
295.3	-	124.6	-	-	-	-	-	61.7	-	54.7	-	42.8	7.9
298.6	-	123.5	-	-	-	-	-	61.3	-	54.4	-	-	-
305.1	-	-	-	-	-	-	-	60.5	-	53.8	-	-	-
308.4	-	-	-	-	-	-	-	60.1	-	53.5	-	-	-
321.5	-	-	-	-	-	-	-	58.6	-	52.5	-	-	-
328.1	-	-	-	-	-	-	-	57.8	-	52.0	-	-	-
331.4	-	-	-	-	-	-	-	57.5	-	-	-	-	-
334.6	-	-	-	-	-	-	-	57.1	-	-	-	-	-
337.9	-	-	-	-	-	-	-	56.9	-	-	-	-	-
347.8	-	-	-	-	-	-	-	-	-	-	-	-	-
360.9	-	-	-	-	-	-	-	-	-	-	-	-	-
364.2	-	-	-	-	-	-	-	-	-	-	-	-	-
374.0	-	-	-	-	-	-	-	-	-	-	-	-	-
377.3	-	-	-	-	-	-	-	-	-	-	-	-	-



Operation

SSL+LF_1

		363,800 lb +  110,200 lb		 36.1-62.3 ft		 27.6 ft		 32.2 ft/s		360°		ASME B30.5			
		315.0 ft													
		SSL+LF_1													
		39.4 ft				78.7 ft				118.1 ft					
		0 lb-716.6 klb		0 lb-716.6 klb		0 lb-716.6 klb		0 lb-716.6 klb		0 lb-716.6 klb		0 lb-716.6 klb		0 lb-716.6 klb	
		0 lb		0 lb		0 lb		0 lb		0 lb		0 lb		0 lb	
		15°		20°		30°		15°		20°		30°		15°	
ft		1,000 lb													
49.2	297.6	368.2	-	-	-	-	-	-	-	-	-	-	-	-	-
52.5	280.0	359.4	269.0	269.0	-	-	-	-	-	-	-	-	-	-	-
59.1	246.9	341.7	251.3	257.9	164.2	164.2	-	-	-	-	-	-	-	-	-
62.3	233.7	332.9	238.1	252.4	162.0	162.0	176.4	177.5	-	-	-	-	-	-	-
65.6	220.5	324.1	224.9	246.9	159.8	159.8	172.0	173.1	-	-	-	-	-	-	-
68.9	209.4	316.4	213.3	242.5	157.6	157.6	168.1	169.2	129.0	129.0	-	-	-	-	-
72.2	198.4	308.6	201.7	238.1	155.4	155.4	164.2	165.3	125.7	125.7	-	-	-	-	-
75.5	189.0	302.0	191.8	233.7	153.2	153.2	160.9	161.5	123.5	123.5	-	-	105.8	106.5	-
78.7	179.7	295.4	181.9	229.3	151.0	151.0	157.6	157.6	121.3	121.3	-	-	103.4	104.3	-
82.0	170.9	288.8	173.1	226.0	149.4	149.4	154.3	154.3	119.0	119.0	76.3	76.3	101.3	102.1	-
85.3	162.0	282.2	164.2	222.7	147.7	147.7	151.0	151.0	116.8	116.8	75.2	75.2	99.2	99.9	-
88.6	154.9	276.7	157.1	218.8	145.5	145.5	147.7	147.7	114.6	114.6	74.2	74.2	97.2	97.9	76.5
91.9	147.7	271.2	149.9	215.0	143.3	143.3	144.4	144.4	112.4	112.4	73.2	73.2	95.2	95.9	75.2
98.4	134.5	260.1	136.7	208.3	140.0	140.0	137.8	138.9	109.1	109.1	71.2	71.2	91.5	92.2	72.8
105.0	124.0	251.3	126.0	202.1	129.3	137.1	127.7	133.7	105.7	105.7	69.5	69.5	88.4	89.0	70.5
111.5	113.6	242.5	115.4	195.8	118.5	134.1	117.7	128.6	102.4	102.4	67.8	67.8	85.3	85.8	68.2
124.7	95.4	226.7	96.9	184.8	99.7	128.6	99.9	119.4	95.0	96.2	64.7	64.7	79.5	80.0	64.0
137.8	79.8	212.7	81.1	175.3	83.6	123.5	84.4	111.3	87.1	90.6	61.7	61.7	74.1	74.5	60.2
150.9	65.6	201.0	66.9	166.4	69.2	119.0	72.4	104.9	74.9	85.9	59.2	59.2	69.5	70.0	57.0
164.0	53.0	190.0	54.2	158.7	56.3	115.0	61.3	98.9	63.6	81.6	56.9	56.9	63.3	65.7	53.9
177.2	42.1	179.7	43.2	152.1	45.0	111.3	51.1	93.5	53.1	77.6	54.7	54.7	55.6	61.7	50.9
190.3	33.6	171.6	34.5	146.2	36.2	108.5	42.3	88.8	44.2	74.1	46.7	46.7	47.8	58.6	47.8
203.4	25.9	163.9	26.7	140.7	28.2	105.8	34.3	84.4	36.0	70.9	38.9	38.9	40.3	55.9	42.7
216.5	19.2	156.5	19.8	135.6	21.2	103.2	27.1	80.2	28.7	68.1	31.3	29.6	33.3	53.6	35.5
229.7	13.6	150.6	14.3	131.2	15.4	101.0	21.4	76.9	22.6	65.5	25.1	25.1	48.1	51.2	29.2
242.8	8.4	145.3	9.0	127.1	10.1	99.0	16.0	73.7	17.1	63.1	19.4	19.4	46.8	49.0	23.4
246.1	-	144.0	7.7	126.2	8.8	98.5	14.8	73.0	15.9	62.6	18.1	18.1	46.5	48.5	22.2
255.9	-	140.0	-	123.5	-	97.2	11.0	70.8	12.1	61.1	14.1	14.1	45.6	47.0	18.3
265.7	-	136.7	-	121.3	-	96.3	7.9	68.9	9.0	59.6	10.8	10.8	45.0	45.5	14.9
269.0	-	135.6	-	120.5	-	96.0	-	68.3	7.9	59.1	9.7	9.7	44.8	45.0	13.7
272.3	-	134.5	-	119.8	-	95.7	-	67.6	-	58.6	8.6	8.6	44.5	44.6	12.6
282.2	-	131.5	-	117.6	-	-	-	65.9	-	57.4	-	-	43.9	8.2	43.3
285.4	-	130.6	-	116.8	-	-	-	65.4	-	57.0	-	-	43.8	-	42.9
295.3	-	127.9	-	114.6	-	-	-	63.7	-	55.8	-	-	43.2	-	41.7
308.4	-	124.9	-	96.6	-	-	-	61.8	-	54.5	-	-	42.5	-	40.2
318.2	-	123.5	-	-	-	-	-	60.5	-	53.6	-	-	-	-	39.1
321.5	-	-	-	-	-	-	-	60.1	-	53.4	-	-	-	-	38.8
334.6	-	-	-	-	-	-	-	58.6	-	52.2	-	-	-	-	37.5
344.5	-	-	-	-	-	-	-	57.8	-	51.8	-	-	-	-	36.6
347.8	-	-	-	-	-	-	-	57.5	-	-	-	-	-	-	36.3
354.3	-	-	-	-	-	-	-	56.9	-	-	-	-	-	-	35.7
360.9	-	-	-	-	-	-	-	-	-	-	-	-	-	-	35.3
374.0	-	-	-	-	-	-	-	-	-	-	-	-	-	-	34.4
380.6	-	-	-	-	-	-	-	-	-	-	-	-	-	-	34.2
387.1	-	-	-	-	-	-	-	-	-	-	-	-	-	-	33.8
393.7	-	-	-	-	-	-	-	-	-	-	-	-	-	-	33.5

	0 lb	143,300 lb	275,600 lb	363,800 lb	452,000 lb	584,300 lb	716,600 lb
---	------	------------	------------	------------	------------	------------	------------

Operation





SSL+LF_1

363,800 lb +		110,200 lb		36.1-62.3 ft		27.6 ft		32.2 ft/s		360°		ASME B30.5	
334.6 ft													
SSL+LF_1													
39.4 ft				78.7 ft				118.1 ft					
0 lb-716.6 klb		0 lb-716.6 klb		0 lb-716.6 klb		0 lb-716.6 klb		0 lb-716.6 klb		0 lb-716.6 klb		0 lb-716.6 klb	
0 lb		0 lb		0 lb		0 lb		0 lb		0 lb		0 lb	
15°		20°		30°		15°		20°		30°		15°	
20°		30°		15°		20°		30°		15°		20°	
30°		15°		20°		30°		15°		20°		30°	
1,000 lb													
52.5	269.0	354.9	-	-	-	-	-	-	-	-	-	-	-
55.8	253.5	350.5	255.7	266.8	-	-	-	-	-	-	-	-	-
59.1	238.1	346.1	240.3	260.1	-	-	-	-	-	-	-	-	-
62.3	225.4	338.4	228.2	255.7	162.0	162.0	-	-	-	-	-	-	-
65.6	212.7	330.7	216.1	251.3	159.8	159.8	173.1	174.2	-	-	-	-	-
72.2	190.7	315.3	192.9	242.5	156.5	156.5	165.3	167.6	126.8	126.8	-	-	-
78.7	172.0	302.0	174.2	233.7	152.1	152.1	158.7	159.8	122.4	122.4	-	-	-
85.3	155.4	288.8	157.6	224.9	148.8	148.8	153.2	153.2	117.9	117.9	75.4	75.4	99.9
88.6	148.3	283.3	150.5	221.6	147.2	147.2	148.8	149.9	115.7	115.7	74.4	74.4	97.9
91.9	141.1	277.8	143.3	218.3	145.5	145.5	144.4	146.6	113.5	113.5	73.4	73.4	95.9
98.4	127.9	266.8	130.1	211.6	134.5	142.2	132.3	141.1	110.2	110.2	71.7	71.7	92.4
108.3	112.7	253.5	114.6	202.8	118.5	137.2	117.3	133.9	105.4	105.4	69.1	69.1	87.9
111.5	107.6	249.1	109.5	199.9	113.2	135.6	112.3	131.5	103.8	103.8	68.3	68.3	86.3
124.7	89.8	233.0	91.5	188.9	94.6	130.1	94.7	122.4	94.4	97.7	65.2	65.2	80.7
137.8	74.5	218.3	76.1	178.6	78.7	125.7	79.6	113.5	82.2	92.2	62.4	62.4	75.4
150.9	61.4	206.5	62.8	170.5	65.3	121.3	67.7	107.5	70.2	87.5	59.9	59.9	68.8
164.0	49.5	195.5	50.7	162.8	53.0	117.2	57.0	101.6	59.3	83.1	57.0	57.0	60.8
177.2	38.6	185.2	39.7	155.4	41.7	113.5	47.6	95.9	49.6	79.1	53.6	53.6	51.4
190.3	30.1	177.1	31.0	149.5	32.7	110.3	38.9	91.2	40.9	75.8	44.5	53.6	43.6
203.4	22.3	169.4	23.2	144.0	24.7	107.4	31.0	86.8	32.9	72.6	36.1	51.9	36.5
216.5	15.4	162.0	16.3	138.9	17.6	104.7	23.8	82.7	25.6	69.7	28.4	50.3	30.2
229.7	9.8	155.9	10.6	134.5	11.8	102.4	17.9	79.1	19.5	67.0	22.1	48.8	24.2
232.9	8.4	154.3	9.1	133.4	10.3	101.9	16.5	78.3	18.0	66.4	20.5	48.4	22.7
236.2	-	152.1	7.7	132.3	8.8	101.2	15.0	77.4	16.5	65.7	19.0	48.1	21.2
242.8	-	149.5	-	130.1	-	100.2	12.5	75.9	14.0	64.6	16.3	47.5	18.6
252.6	-	145.7	-	126.8	-	98.8	8.8	73.7	10.1	63.1	12.3	46.6	14.7
255.9	-	144.4	-	125.7	-	98.3	-	73.0	8.8	62.4	11.0	46.3	13.4
259.2	-	143.3	-	124.9	-	98.0	-	72.3	7.7	61.9	9.8	46.1	12.3
262.5	-	142.2	-	124.2	-	97.6	-	71.7	-	61.5	8.6	45.9	11.2
269.0	-	140.0	-	122.7	-	96.9	-	70.3	-	60.5	-	45.4	9.0
272.3	-	138.9	-	122.0	-	96.5	-	69.7	-	60.0	-	45.2	7.9
275.6	-	137.8	-	121.3	-	96.1	-	69.0	-	59.5	-	45.0	-
282.2	-	135.6	-	119.8	-	95.5	-	67.8	-	58.7	-	44.5	-
285.4	-	134.5	-	119.0	-	95.2	-	67.2	-	58.3	-	44.3	-
295.3	-	131.2	-	116.8	-	-	-	65.5	-	57.1	-	43.7	-
308.4	-	127.5	-	114.6	-	-	-	63.6	-	55.8	-	43.1	-
321.5	-	121.3	-	113.5	-	-	-	61.8	-	54.5	-	42.5	-
324.8	-	119.0	-	96.3	-	-	-	61.4	-	54.2	-	-	-
334.6	-	112.4	-	-	-	-	-	60.2	-	53.4	-	-	-
347.8	-	-	-	-	-	-	-	58.7	-	52.5	-	-	-
360.9	-	-	-	-	-	-	-	57.5	-	51.6	-	-	-
370.7	-	-	-	-	-	-	-	56.7	-	-	-	-	-
374.0	-	-	-	-	-	-	-	-	-	-	-	-	-
387.1	-	-	-	-	-	-	-	-	-	-	-	-	-
397.0	-	-	-	-	-	-	-	-	-	-	-	-	-
400.3	-	-	-	-	-	-	-	-	-	-	-	-	-
410.1	-	-	-	-	-	-	-	-	-	-	-	-	-

	0 lb	143,300 lb	275,600 lb	363,800 lb	452,000 lb	584,300 lb	716,600 lb
--	------	------------	------------	------------	------------	------------	------------

Operation

SSL+LF_1

363,800 lb +  110,200 lb		 36.1-62.3 ft		 27.6 ft		 32.2 ft/s		360°		ASME B30.5	
354.3 ft											
SSL+LF_1											
39.4 ft				78.7 ft				118.1 ft			
0 lb - 716.6 klb		0 lb - 716.6 klb		0 lb - 716.6 klb		0 lb - 716.6 klb		0 lb - 716.6 klb		0 lb - 716.6 klb	
0 lb		0 lb		0 lb		0 lb		0 lb		0 lb	
15°		20°		30°		15°		20°		30°	
1,000 lb											
52.5	257.9	339.5	-	-	-	-	-	-	-	-	-
55.8	242.5	339.5	244.7	269.0	-	-	-	-	-	-	-
59.1	227.1	339.5	231.5	262.4	-	-	-	-	-	-	-
62.3	215.0	335.1	218.8	257.9	163.1	163.1	-	-	-	-	-
65.6	202.8	330.7	206.1	253.5	160.9	160.9	174.2	175.3	-	-	-
72.2	181.9	319.7	185.2	244.7	157.6	157.6	166.4	168.7	127.9	127.9	-
78.7	164.2	306.4	166.4	235.9	153.2	153.2	160.9	162.0	123.5	123.5	-
85.3	147.7	295.4	149.9	229.3	149.9	149.9	152.1	155.4	119.0	119.0	75.8
91.9	133.4	284.4	135.6	222.7	141.1	146.6	137.8	149.9	115.7	115.7	73.9
98.4	121.3	274.4	123.5	215.0	127.9	143.3	125.7	143.3	111.3	111.3	72.1
108.3	106.4	260.1	108.4	206.1	112.2	138.9	111.1	136.1	105.6	106.7	69.6
111.5	101.4	255.7	103.3	203.2	107.0	137.4	106.3	133.7	103.7	105.2	68.7
124.7	83.9	239.6	85.6	192.5	88.8	131.9	89.1	124.9	92.3	99.4	65.6
137.8	68.8	224.9	70.3	183.0	73.2	126.8	74.1	116.8	77.2	93.9	62.8
150.9	56.9	212.4	58.3	174.2	61.0	122.4	62.5	110.2	65.3	89.2	60.5
164.0	45.4	201.0	46.7	166.1	49.2	118.3	52.0	104.1	54.5	84.9	55.9
177.2	34.4	190.7	35.7	158.7	37.7	114.6	42.8	98.5	45.0	80.9	48.9
190.3	25.9	181.9	26.9	152.9	28.9	111.7	35.0	93.7	37.0	77.4	40.7
203.4	18.2	173.8	19.0	147.3	20.9	108.9	27.4	89.2	29.3	74.1	32.8
216.5	11.2	166.4	12.1	142.2	13.7	106.3	20.1	85.1	21.8	71.2	25.1
223.1	8.4	163.6	9.0	140.0	10.6	105.0	17.1	83.3	18.8	69.9	22.0
226.4	-	161.8	-	138.9	9.0	104.4	15.7	82.5	17.3	69.2	20.4
229.7	-	160.1	-	137.8	-	103.7	14.2	81.6	15.8	68.6	18.8
242.8	-	154.0	-	133.4	-	101.6	8.6	78.2	10.1	66.2	12.9
246.1	-	152.7	-	132.3	-	101.1	-	77.4	8.8	65.7	11.6
252.6	-	150.1	-	130.1	-	100.1	-	75.8	-	64.5	8.8
255.9	-	148.8	-	129.0	-	99.6	-	75.0	-	63.9	-
259.2	-	147.5	-	128.1	-	99.2	-	74.3	-	63.4	-
265.7	-	145.0	-	126.2	-	98.4	-	73.0	-	62.4	-
269.0	-	143.7	-	125.3	-	98.0	-	72.3	-	61.9	-
275.6	-	141.1	-	123.5	-	97.2	-	71.0	-	60.8	-
282.2	-	139.3	-	122.4	-	96.6	-	69.8	-	60.0	-
295.3	-	135.6	-	120.2	-	95.2	-	67.5	-	58.4	-
301.8	-	130.8	-	118.7	-	92.8	-	66.4	-	57.7	-
308.4	-	126.0	-	117.2	-	-	-	65.4	-	57.0	-
321.5	-	118.2	-	114.6	-	-	-	63.5	-	55.6	-
334.6	-	110.2	-	110.2	-	-	-	61.7	-	54.2	-
337.9	-	108.1	-	108.6	-	-	-	61.4	-	54.0	-
341.2	-	105.9	-	106.9	-	-	-	61.0	-	53.8	-
347.8	-	101.6	-	-	-	-	-	60.3	-	53.3	-
351.1	-	99.4	-	-	-	-	-	59.9	-	53.0	-
360.9	-	-	-	-	-	-	-	58.9	-	52.3	-
374.0	-	-	-	-	-	-	-	57.5	-	51.6	-
377.3	-	-	-	-	-	-	-	57.3	-	51.4	-
387.1	-	-	-	-	-	-	-	56.7	-	-	-
390.4	-	-	-	-	-	-	-	56.4	-	-	-
400.3	-	-	-	-	-	-	-	-	-	-	-
413.4	-	-	-	-	-	-	-	-	-	-	-
426.5	-	-	-	-	-	-	-	-	-	-	-

	0 lb	143,300 lb	275,600 lb	363,800 lb	452,000 lb	584,300 lb	716,600 lb
---	------	------------	------------	------------	------------	------------	------------

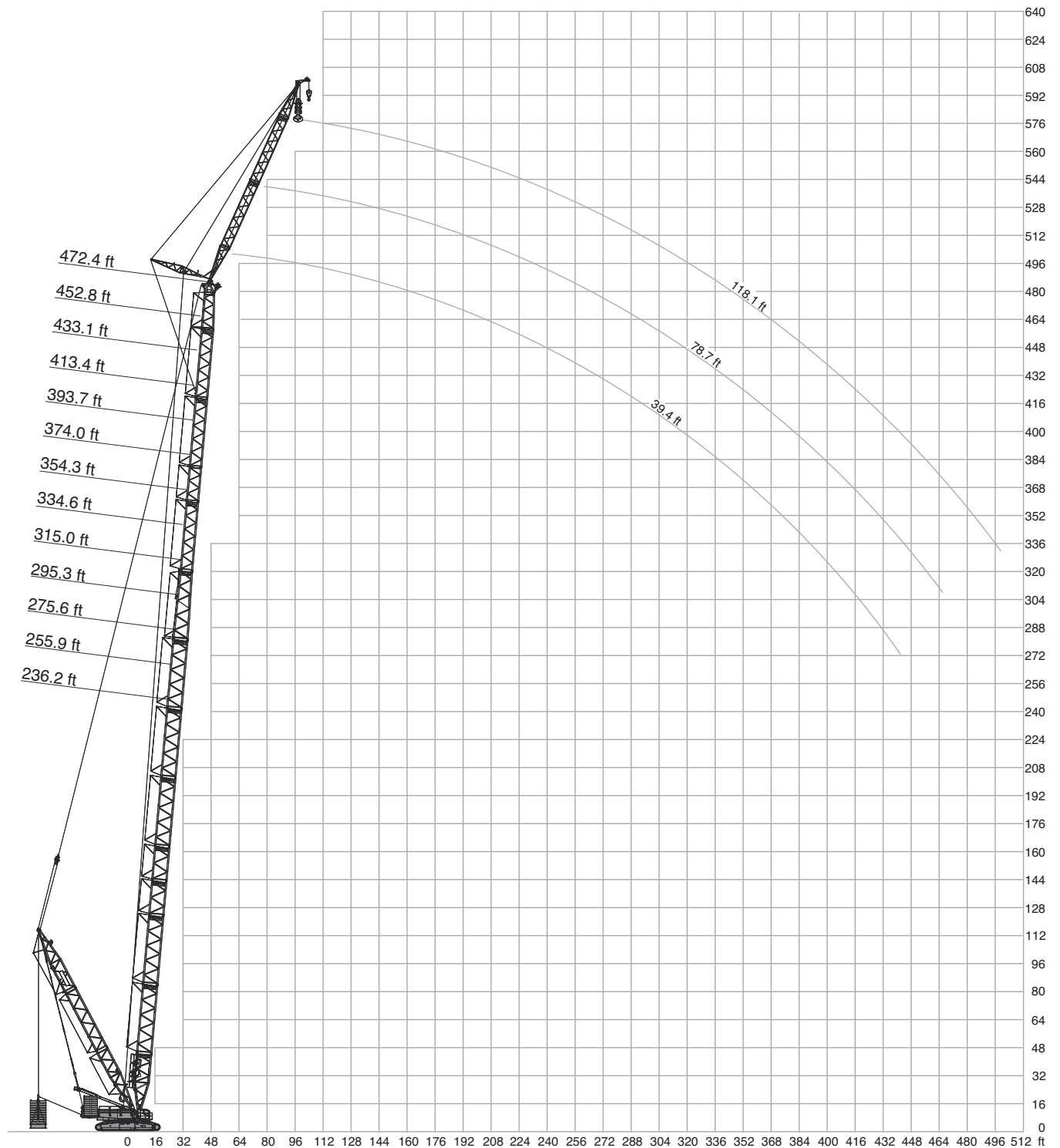

Operation

LSL+LF_3, LSL+LF_4
 LSL+LF_6, LSL+LF_8
 LSL+LF_10, LSL+LF_12

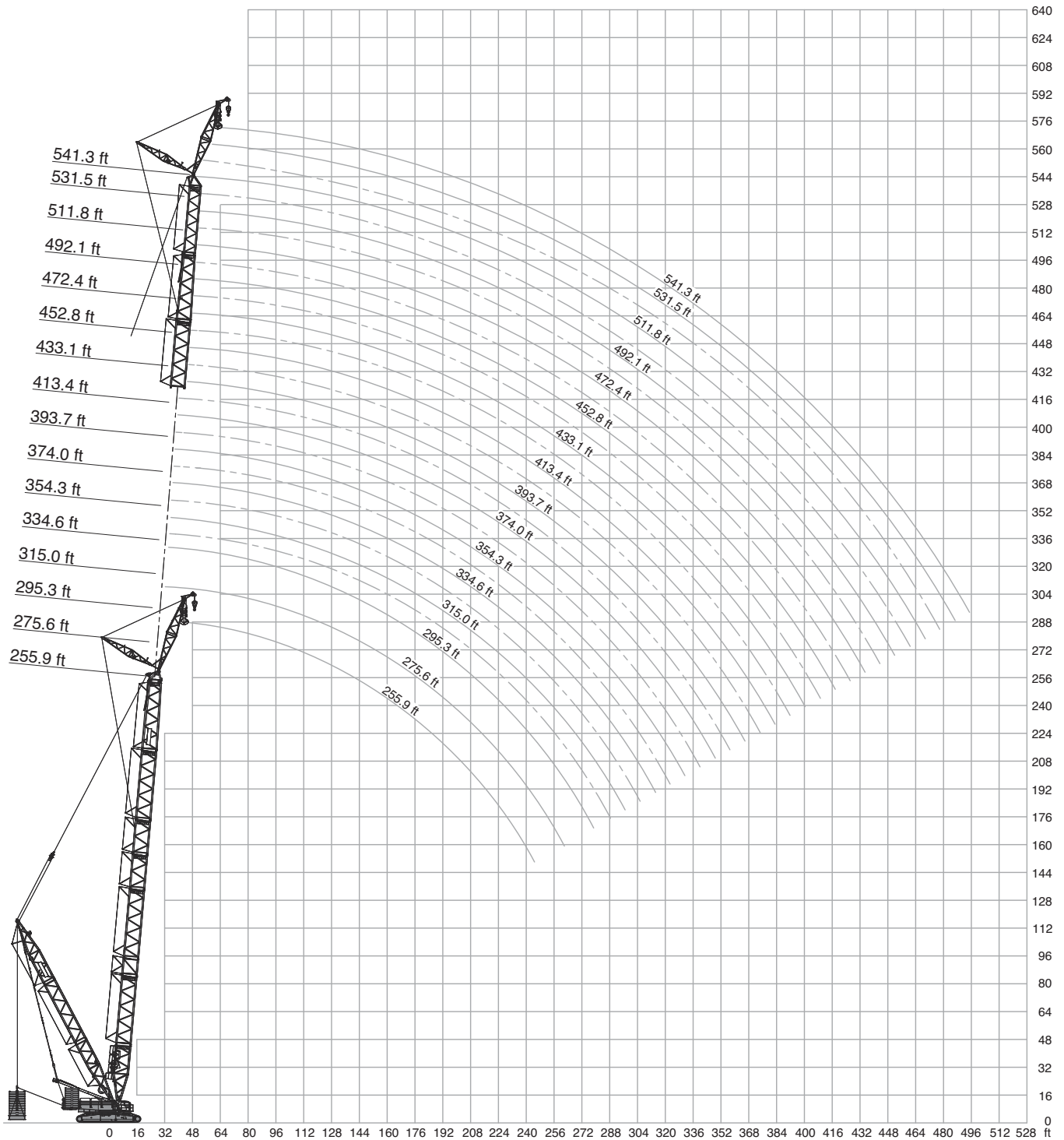

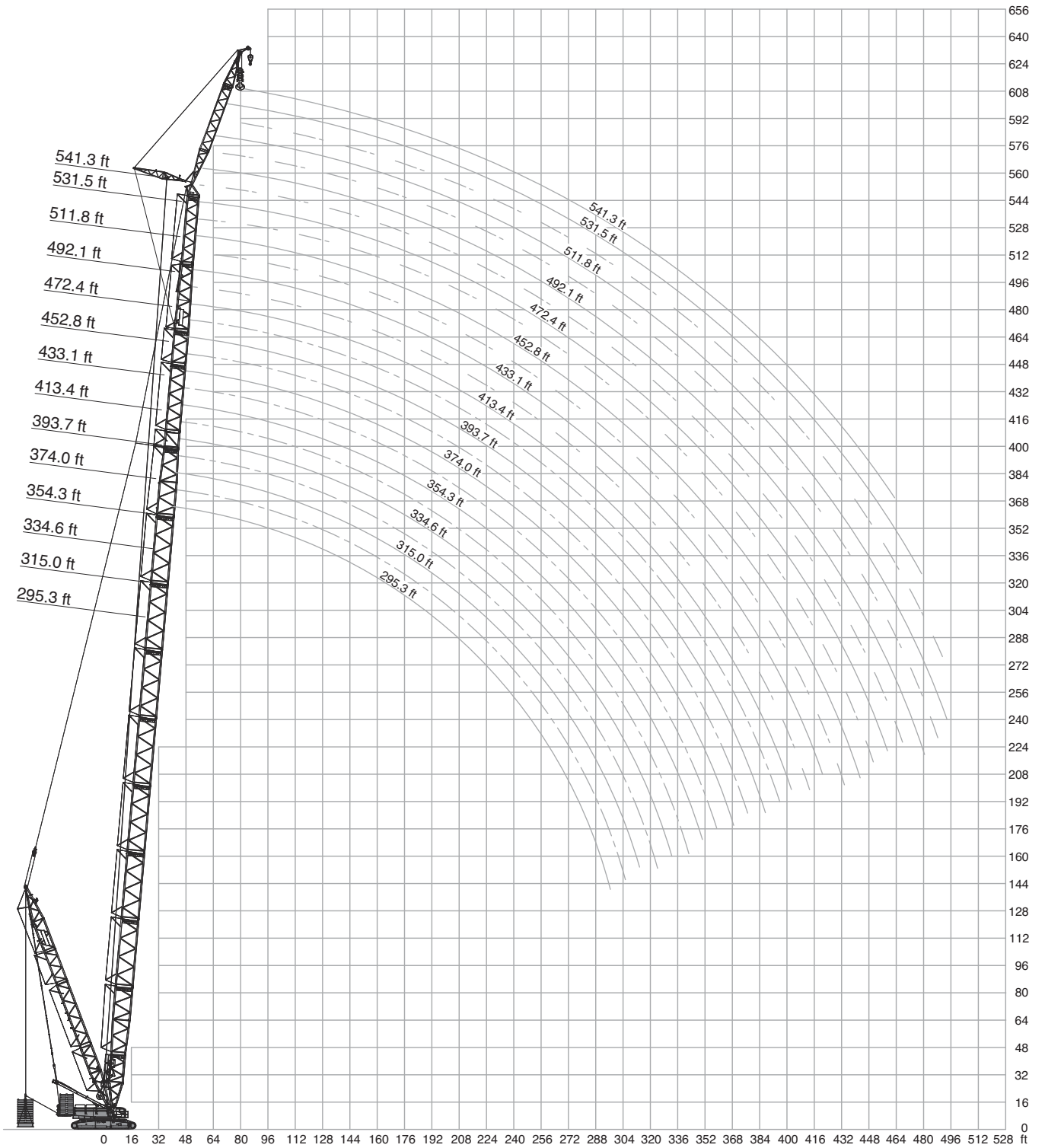

Operation





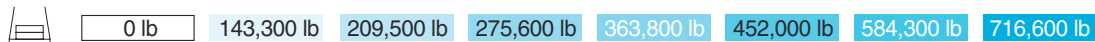

LSL+LF

363,800 lb +		110,200 lb		36.1-62.3 ft			27.6 ft		32.2 ft/s			360°		ASME B30.5	
236.2 ft				255.9 ft				275.6 ft							
LSL+LF_2				LSL+LF_3				LSL+LF_2				LSL+LF_3			
39.4 ft															
0 lb		0-716.6 klb		0 lb		0-716.6 klb		0 lb		0-716.6 klb		0 lb		0-716.6 klb	
15°		20°		30°		15°		20°		30°		15°		20°	
1,000 lb															
ft															ft
39.4	392.4	392.4	-	-	-	-	-	-	-	-	-	-	-	-	39.4
42.7	377.0	380.3	291.0	-	372.6	388.0	-	-	-	-	-	357.1	392.4	-	42.7
45.9	361.6	368.2	282.2	-	346.1	374.8	286.6	-	335.1	343.9	273.4	332.9	381.4	291.0	45.9
49.2	339.5	357.1	275.6	179.7	325.2	363.8	280.0	-	317.5	335.1	266.8	313.1	371.5	284.4	49.2
52.5	317.5	346.1	269.0	176.4	304.2	352.7	273.4	178.6	299.8	326.3	260.1	293.2	361.6	277.8	52.5
59.1	280.0	326.3	255.7	170.9	269.0	332.9	260.1	172.0	266.8	308.6	249.1	260.1	341.7	264.6	59.1
65.6	251.3	308.6	244.7	164.2	240.3	315.3	249.1	166.4	238.1	295.4	240.3	233.7	324.1	253.5	65.6
72.2	227.1	291.0	233.7	159.8	217.2	299.8	238.1	162.0	216.6	281.1	229.3	210.5	308.6	244.7	72.2
78.7	206.1	277.8	224.9	154.3	197.3	286.6	229.3	156.5	195.1	266.8	220.5	190.7	293.2	233.7	78.7
85.3	187.4	264.6	216.1	149.9	179.7	273.4	220.5	152.1	178.6	255.7	212.7	174.2	282.2	224.9	85.3
91.9	172.0	253.5	207.2	145.5	164.2	262.4	212.7	147.7	162.0	244.7	205.0	158.7	269.0	218.3	91.9
98.4	157.6	242.5	199.5	141.1	151.0	251.3	206.1	144.4	149.4	234.8	198.4	145.5	257.9	210.5	98.4
111.5	132.6	224.9	187.0	134.5	128.2	232.2	192.9	137.1	126.2	216.6	185.9	124.9	240.3	198.0	111.5
124.7	111.4	208.7	175.6	128.2	108.1	215.7	181.1	130.8	106.9	202.5	174.9	106.0	224.1	186.7	124.7
137.8	93.9	194.0	165.3	122.4	90.6	201.7	170.9	125.7	89.3	190.7	165.3	88.6	209.4	176.4	137.8
150.9	81.1	183.0	157.3	117.9	77.7	190.7	162.0	120.5	76.4	180.4	157.3	75.3	197.7	167.6	150.9
164.0	69.7	172.7	149.5	113.9	66.0	180.4	154.3	116.1	64.7	170.9	149.5	63.4	187.0	159.5	164.0
177.2	59.5	163.1	142.2	110.2	55.6	170.9	147.7	112.4	54.5	162.0	142.2	53.1	177.5	152.1	177.2
190.3	51.6	155.8	137.1	107.6	47.6	162.8	141.8	109.8	46.5	154.7	136.3	45.0	168.7	146.2	190.3
203.4	44.5	149.2	132.3	105.2	40.4	155.4	136.3	107.2	39.4	147.7	131.2	37.8	160.9	140.7	203.4
213.3	39.7	144.8	129.0	103.6	35.6	150.5	132.5	105.3	34.6	142.7	127.9	32.9	156.0	136.9	213.3
216.5	38.1	143.3	127.9	-	34.0	148.8	131.2	104.7	33.1	141.1	126.8	31.3	154.3	135.6	216.5
226.4	34.3	139.4	125.1	-	30.1	145.0	128.4	103.4	29.2	137.2	124.0	27.4	149.9	132.3	226.4
229.7	33.0	138.2	124.2	-	28.8	143.7	127.5	-	27.9	136.0	123.1	26.2	148.4	131.2	229.7
239.5	29.3	134.8	122.4	-	25.2	140.0	124.9	-	24.3	132.5	120.7	22.5	144.4	128.2	239.5
242.8	28.2	133.9	-	-	24.1	138.9	124.2	-	23.2	131.5	120.2	21.4	143.3	127.5	242.8
249.3	26.0	132.3	-	-	22.0	136.7	122.7	-	21.1	129.7	119.0	19.2	141.1	126.0	249.3
255.9	-	-	-	-	19.8	134.5	121.3	-	19.0	127.9	117.9	17.0	138.9	124.6	255.9
265.7	-	-	-	-	17.2	132.3	-	-	16.3	125.7	-	14.3	136.1	122.6	265.7
269.0	-	-	-	-	-	-	-	-	-	-	-	13.4	135.2	121.9	269.0
272.3	-	-	-	-	-	-	-	-	-	-	-	12.6	134.3	121.3	272.3
282.2	-	-	-	-	-	-	-	-	-	-	-	10.1	131.2	-	282.2



Operation

LSL+LF

 363,800 lb + 110,200 lb  36.1-68.9 ft  27.6 ft  32.2 ft/s  360°  ASME B30.5																	
 295.3 ft 305.1 ft																	
LSL+LF_2 LSL+LF_3 LSL+LF_6 LSL+LF_14 LSL+LF_6 LSL+LF_14																	
39.4 ft																	
0 lb 0-716.6 klb 0 lb 0-716.6 klb 0 lb 0-716.6 klb																	
15° 20° 30° 15° 20° 15° 20° 15° 20° 15° 20°																	
ft 1,000 lb ft																	
45.9	319.7	379.2	-	-	-	-	-	341.7	-	388.0	-	302.0	346.1	-	392.4	-	45.9
49.2	300.9	373.7	286.6	-	295.4	324.1	271.2	332.9	257.9	382.5	282.2	283.3	336.2	257.9	386.9	284.4	49.2
52.5	282.2	368.2	280.0	-	277.8	319.7	266.8	324.1	251.3	377.0	275.6	264.6	326.3	253.5	381.4	277.8	52.5
55.8	265.7	358.3	274.5	177.5	262.4	315.3	261.2	316.4	245.8	367.1	270.1	249.1	318.6	248.0	371.5	272.3	55.8
59.1	249.1	348.3	269.0	175.3	246.9	310.9	255.7	308.6	240.3	357.1	264.6	233.7	310.9	242.5	361.6	266.8	59.1
65.6	222.7	330.7	257.9	169.8	220.5	302.0	246.9	293.2	231.5	339.5	253.5	208.3	295.4	233.7	343.9	255.7	65.6
72.2	201.7	315.3	249.1	165.3	200.6	291.0	238.1	280.0	222.7	324.1	244.7	187.9	283.3	224.9	328.5	246.9	72.2
78.7	183.0	302.0	238.1	160.9	180.8	280.0	229.3	266.8	215.0	308.6	235.9	167.6	271.2	216.1	313.1	238.1	78.7
85.3	166.4	288.8	229.3	156.5	165.3	269.0	220.5	255.7	207.2	296.5	228.2	152.7	260.1	209.4	299.8	230.4	85.3
91.9	152.1	277.8	222.7	152.1	149.9	257.9	213.8	244.7	199.5	284.4	220.5	137.8	249.1	201.7	286.6	222.7	91.9
98.4	138.9	266.8	216.1	148.8	137.8	249.1	207.2	235.9	192.9	273.4	213.3	126.2	240.3	195.1	276.7	215.5	98.4
111.5	118.9	247.7	202.8	142.2	116.6	231.5	194.7	219.9	181.9	253.5	200.1	105.3	223.2	184.1	256.8	202.3	111.5
124.7	101.1	231.1	191.1	136.0	99.9	216.1	183.7	206.1	171.6	235.9	189.0	88.6	208.3	173.8	239.2	191.3	124.7
137.8	85.5	217.2	180.8	130.1	84.4	202.8	174.2	192.9	162.0	220.8	179.7	73.9	195.1	164.2	224.9	181.9	137.8
150.9	71.7	204.7	172.0	125.7	70.8	193.3	166.8	181.9	154.0	208.3	170.9	61.1	184.8	156.2	211.6	173.1	150.9
164.0	59.6	193.3	163.9	121.3	58.8	183.7	159.5	172.0	146.6	197.3	162.8	49.5	175.3	148.8	200.6	165.0	164.0
177.2	49.2	183.0	156.5	116.8	48.5	174.2	152.1	163.1	140.0	187.4	155.8	39.0	166.4	142.2	190.3	158.0	177.2
190.3	41.1	174.9	150.6	113.9	40.4	166.1	146.2	155.8	134.8	178.6	149.9	30.9	158.4	137.1	180.8	152.1	190.3
203.4	33.8	167.2	145.1	111.1	33.2	158.7	140.7	148.8	130.1	170.5	144.0	23.7	151.4	131.9	173.4	146.2	203.4
216.5	27.3	159.8	140.0	108.5	26.9	152.1	135.6	142.2	125.7	163.1	138.9	17.2	145.5	126.8	166.4	141.1	216.5
229.7	22.0	154.0	135.6	106.1	21.6	146.2	131.2	137.1	121.3	156.5	134.5	12.1	139.6	123.2	159.8	136.7	229.7
239.5	18.3	149.7	132.5	104.5	17.9	142.0	128.1	133.4	118.5	152.7	131.7	8.2	135.6	120.3	155.4	133.9	239.5
242.8	17.2	148.4	131.5	104.1	16.8	140.7	127.1	132.3	117.9	151.4	130.8	-	134.5	119.4	154.0	133.0	242.8
255.9	12.8	143.3	127.9	102.5	12.6	135.6	123.5	127.9	114.6	146.6	127.5	-	130.1	115.7	148.8	129.4	255.9
269.0	9.3	138.9	124.9	-	8.9	132.3	120.8	124.2	111.7	142.2	124.6	-	126.4	112.8	144.4	125.7	269.0
272.3	8.4	137.8	124.2	-	7.9	131.2	120.2	123.3	111.0	141.1	124.6	-	125.5	112.1	143.3	125.1	272.3
282.2	-	135.2	122.4	-	-	128.6	117.9	120.9	109.7	138.5	122.6	-	123.1	110.6	140.0	123.5	282.2
288.7	-	133.7	121.3	-	-	127.1	116.8	119.4	109.1	136.7	121.3	-	121.6	109.9	137.8	122.4	288.7
295.3	-	132.3	-	-	-	125.7	-	117.9	-	135.2	-	-	120.2	109.1	136.3	121.6	295.3
298.6	-	131.2	-	-	-	125.7	-	117.9	-	134.5	-	-	119.3	101.0	135.6	121.3	298.6
308.4	-	-	-	-	-	-	-	-	-	-	-	-	116.8	-	133.4	-	308.4

143,300 lb
209,500 lb
275,600 lb
363,800 lb
452,000 lb
584,300 lb
716,600 lb





LSL+LF_2 – LSL+LF_6:  **36.1 ft – 62.3 ft**

LSL+LF_14:  **42.7 ft – 68.9 ft**

LSL+LF_14:  **496,100 lb + 110,200 lb**

Operation

LSL+LF

363,800 lb +  110,200 lb		 36.1-68.9 ft		 27.6 ft		 32.2 ft/s		360°		ASME B30.5								
315.0 ft																		
LSL+LF_2		LSL+LF_3		LSL+LF_4		LSL+LF_6		LSL+LF_8		LSL+LF_10		LSL+LF_14						
39.4 ft																		
0 lb		0-716.6 klb		0 lb		0-716.6 klb		0 lb		0-716.6 klb		0 lb						
15°		20°		30°		15°		20°		15°		20°						
1,000 lb																		
ft															ft			
45.9	308.6	346.1	-	-	-	-	-	-	348.3	-	324.1	392.4	-	392.4	-	392.4	-	45.9
49.2	289.9	345.0	291.0	-	284.4	317.5	271.2	-	338.4	260.1	304.2	390.2	-	390.2	-	388.0	-	49.2
52.5	271.2	343.9	284.4	-	266.8	315.3	269.0	-	328.5	253.5	284.4	388.0	284.4	388.0	284.4	383.6	280.0	52.5
55.8	255.7	342.8	278.9	178.6	251.3	312.0	264.6	-	320.8	249.1	269.0	378.1	278.9	378.1	278.9	373.7	274.5	55.8
59.1	240.3	341.7	273.4	176.4	235.9	308.6	260.1	-	313.1	244.7	253.5	368.2	273.4	368.2	273.4	363.8	269.0	59.1
65.6	217.2	337.3	262.4	170.9	212.7	302.0	249.1	-	297.6	233.7	227.1	352.7	264.6	352.7	264.6	346.1	257.9	65.6
72.2	195.1	321.9	251.3	166.4	192.9	292.1	240.3	-	285.5	224.9	206.1	337.3	255.7	337.3	255.7	330.7	249.1	72.2
78.7	176.4	308.6	242.5	162.0	173.1	282.2	233.7	-	273.4	218.3	185.2	321.9	246.9	321.9	246.9	317.5	240.3	78.7
85.3	160.9	295.4	233.7	157.6	158.2	272.3	224.9	-	262.4	210.5	169.2	309.7	238.1	309.7	238.1	304.2	232.6	85.3
91.9	146.6	284.4	227.1	154.3	143.3	262.4	218.3	-	251.3	203.9	153.2	297.6	231.5	297.6	231.5	291.0	224.9	91.9
98.4	134.5	273.4	220.5	149.9	131.7	254.6	211.6	-	242.5	197.3	140.5	286.6	222.7	286.6	222.7	280.0	217.7	98.4
111.5	114.8	254.3	207.2	144.0	110.9	239.2	199.2	-	226.0	186.3	118.3	266.8	210.9	266.8	210.9	260.1	204.5	111.5
124.7	97.6	237.4	195.5	138.2	94.3	224.5	188.1	-	211.6	176.0	100.9	249.9	200.3	249.9	200.3	243.6	193.5	124.7
137.8	82.9	222.7	185.2	132.3	79.6	210.5	178.6	-	198.4	166.4	85.3	233.7	190.7	233.7	190.7	228.9	184.1	137.8
150.9	69.5	210.9	176.4	127.9	66.7	199.5	171.2	-	187.4	158.4	71.2	221.9	181.9	221.9	181.9	215.0	175.3	150.9
164.0	57.6	199.9	168.3	123.5	55.0	189.6	163.9	-	177.5	151.0	58.7	210.5	173.8	210.5	173.8	203.9	167.2	164.0
177.2	47.2	189.6	160.9	119.0	44.5	180.8	156.5	-	168.7	144.4	47.8	199.5	166.4	199.5	166.4	193.6	159.8	177.2
190.3	38.9	180.8	155.1	115.4	36.4	172.7	150.6	-	161.3	138.5	39.2	190.7	159.8	190.7	159.8	184.1	153.2	190.3
203.4	31.6	172.7	149.2	112.4	29.2	165.0	144.8	-	154.3	133.4	31.4	182.6	154.0	182.6	154.0	176.0	148.1	203.4
216.5	25.1	165.3	143.3	110.2	22.7	157.6	138.9	-	147.7	129.0	24.5	175.3	148.8	175.3	148.8	168.7	143.3	216.5
229.7	19.8	159.5	138.9	107.9	17.4	151.8	134.5	-	142.2	124.6	18.9	168.7	144.4	168.7	144.4	162.0	138.9	229.7
242.8	15.0	153.6	134.8	105.7	12.6	145.9	130.4	-	136.7	120.5	13.8	162.7	140.4	162.7	140.4	156.2	134.5	242.8
255.9	10.6	147.7	131.2	103.8	8.4	140.0	126.8	-	132.3	116.8	9.3	156.5	136.7	156.5	136.7	151.0	130.6	255.9
259.2	9.6	146.6	130.1	103.5	-	139.1	125.8	-	131.2	116.3	8.2	155.4	136.0	155.4	136.0	149.9	129.8	259.2
265.7	7.7	144.4	128.3	102.7	-	137.2	124.0	-	129.0	115.2	-	153.2	134.5	153.2	134.5	147.7	128.4	265.7
269.0	-	143.3	127.4	102.3	-	136.3	123.1	-	127.9	114.6	-	152.1	133.7	152.1	133.7	146.6	127.9	269.0
282.2	-	139.3	124.6	-	-	132.6	120.2	-	124.2	112.4	-	148.1	130.8	148.1	130.8	142.2	124.9	282.2
295.3	-	135.6	122.4	-	-	129.0	117.9	-	121.3	110.0	-	144.4	127.9	144.4	127.9	138.5	122.6	295.3
305.1	-	133.4	121.3	-	-	127.3	116.8	-	119.6	108.7	-	142.2	126.8	142.2	126.8	136.3	121.3	305.1
308.4	-	132.6	-	-	-	126.8	-	-	119.0	-	-	141.5	-	141.5	-	135.6	-	308.4
315.0	-	131.2	-	-	-	125.7	-	-	117.9	-	-	140.0	-	140.0	-	133.4	-	315.0

 0 lb 143,300 lb 209,500 lb 275,600 lb 363,800 lb 452,000 lb 584,300 lb 716,600 lb

LSL+LF_2 – LSL+LF_6:  36.1 ft – 62.3 ft

LSL+LF_8 – LSL+LF_10:  36.1 ft – 68.9 ft

LSL+LF_14:  42.7 ft – 68.9 ft

LSL+LF_14:  496,100 lb +  110,200 lb

Operation

LSL+LF

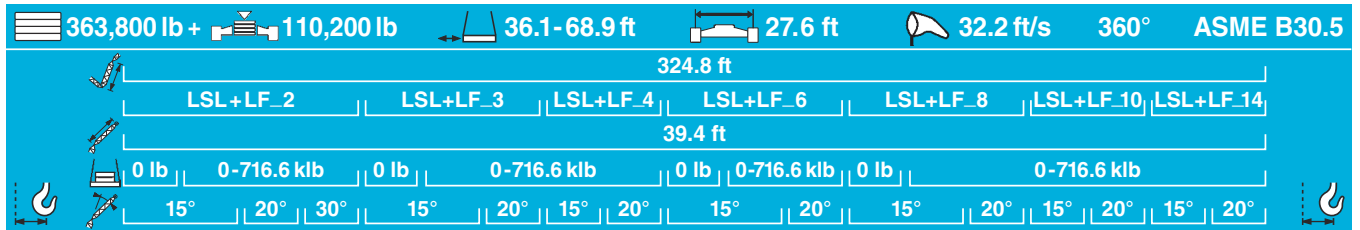

ft	1,000 lb																ft		
49.2	-	-	-	-	-	-	-	-	269.0	339.5	-	297.6	392.4	-	392.4	-	392.4	-	49.2
52.5	-	-	-	-	-	-	-	-	251.3	332.9	255.7	277.8	390.2	286.6	390.2	286.6	388.0	280.0	52.5
59.1	-	-	-	-	-	-	-	-	222.7	315.3	244.7	246.9	372.6	275.6	372.6	275.6	368.2	269.0	59.1
65.6	-	-	-	-	-	-	-	-	198.4	302.0	235.9	220.5	354.9	266.8	354.9	266.8	350.5	260.1	65.6
72.2	-	-	-	-	-	-	-	-	179.1	288.8	227.1	200.1	340.6	255.7	340.6	255.7	335.1	249.1	72.2
78.7	-	-	-	-	-	-	-	-	159.8	275.6	220.5	179.7	326.3	246.9	326.3	246.9	319.7	240.3	78.7
85.3	-	-	-	-	-	-	-	-	145.5	265.7	212.7	164.2	313.1	240.3	313.1	240.3	307.5	232.6	85.3
91.9	-	-	-	-	-	-	-	-	131.2	255.7	206.1	148.8	299.8	231.5	299.8	231.5	295.4	224.9	91.9
98.4	-	-	-	-	-	-	-	-	119.7	245.8	199.5	136.7	289.9	224.9	289.9	224.9	284.4	218.8	98.4
111.5	-	-	-	-	-	-	-	-	99.0	228.2	187.8	114.9	270.1	213.1	270.1	213.1	263.5	206.7	111.5
124.7	-	-	-	-	-	-	-	-	82.5	214.2	177.1	97.4	252.8	202.1	252.8	202.1	245.8	195.7	124.7
137.8	-	-	-	-	-	-	-	-	68.1	201.7	167.6	82.0	238.1	191.8	238.1	191.8	231.5	185.9	137.8
150.9	-	-	-	-	-	-	-	-	56.5	190.7	160.2	68.6	225.6	183.7	225.6	183.7	218.3	176.4	150.9
164.0	-	-	-	-	-	-	-	-	45.5	180.4	153.2	56.4	213.8	176.0	213.8	176.0	207.2	169.0	164.0
177.2	-	-	-	-	-	-	-	-	35.1	170.9	146.6	45.4	202.8	168.7	202.8	168.7	196.9	162.0	177.2
190.3	-	-	-	-	-	-	-	-	27.0	163.5	140.7	36.7	194.0	162.0	194.0	162.0	187.4	155.4	190.3
203.4	-	-	-	-	-	-	-	-	19.6	156.5	135.2	29.0	185.6	156.2	185.6	156.2	179.3	150.3	203.4
216.5	-	-	-	-	-	-	-	-	13.0	149.9	130.1	22.0	177.5	151.0	177.5	151.0	172.0	145.1	216.5
226.4	-	-	-	-	-	-	-	-	8.8	145.7	127.2	17.9	172.5	147.7	172.5	147.7	167.0	141.3	226.4
229.7	-	-	-	-	-	-	-	-	-	144.2	126.3	16.5	170.9	146.6	170.9	146.6	165.3	140.0	229.7
242.8	-	-	-	-	-	-	-	-	-	138.9	122.7	11.3	164.9	142.2	165.3	142.2	159.5	136.3	242.8
252.6	-	-	-	-	-	-	-	-	-	135.6	120.0	7.7	160.9	138.9	161.2	138.9	154.3	133.4	252.6
255.9	-	-	-	-	-	-	-	-	-	134.5	119.0	-	159.8	137.8	159.8	137.8	153.2	132.3	255.9
269.0	-	-	-	-	-	-	-	-	-	130.1	116.1	-	154.7	134.8	154.7	134.8	148.8	129.0	269.0
282.2	-	-	-	-	-	-	-	-	-	126.0	113.2	-	150.3	131.9	150.3	131.9	144.4	126.0	282.2
295.3	-	-	-	-	-	-	-	-	-	122.4	110.2	-	146.6	129.0	146.6	129.0	140.4	123.5	295.3
308.4	-	-	-	-	-	-	-	-	-	120.2	109.2	-	142.9	127.5	142.9	127.5	136.7	121.3	308.4
315.0	-	-	-	-	-	-	-	-	-	119.0	108.5	-	141.1	126.8	141.1	126.8	134.9	121.3	315.0
321.5	-	-	-	-	-	-	-	-	-	117.6	-	-	138.2	-	136.7	-	133.2	-	321.5
324.8	-	-	-	-	-	-	-	-	-	116.8	-	-	136.7	-	134.5	-	132.3	-	324.8



LSL+LF_2 – LSL+LF_6: 36.1 ft – 62.3 ft

LSL+LF_8 – LSL+LF_10: 36.1 ft – 68.9 ft

LSL+LF_14: 42.7 ft – 68.9 ft

LSL+LF_14: 496,100 lb + 110,200 lb

Operation

LSL+LF

363,800 lb + 110,200 lb 36.1-68.9 ft 27.6 ft 32.2 ft/s 360° ASME B30.5																			
334.6 ft																			
LSL+LF_2 LSL+LF_3 LSL+LF_4 LSL+LF_6 LSL+LF_8 LSL+LF_10 LSL+LF_14																			
39.4 ft																			
0-716.6 klb 0 lb 0-716.6 klb 0 lb 0-716.6 klb																			
15° 20° 30° 15° 20° 15° 20° 15° 20° 15° 20° 15° 20° 15° 20°																			
ft																			
1,000 lb																			
ft																			
49.2	277.8	324.1	-	-	-	-	-	315.3	-	341.7	-	291.0	392.4	-	392.4	-	392.4	-	49.2
52.5	260.1	324.1	286.6	-	255.7	306.4	264.6	310.9	273.4	335.1	257.9	273.4	392.4	288.8	392.4	288.8	390.2	282.2	52.5
59.1	231.5	321.9	275.6	177.5	227.1	302.0	260.1	306.4	269.0	317.5	246.9	242.5	374.8	277.8	374.8	277.8	370.4	271.2	59.1
65.6	207.2	319.7	264.6	172.0	203.9	295.4	251.3	302.0	262.4	304.2	238.1	217.2	357.1	266.8	357.1	266.8	352.7	260.1	65.6
72.2	187.4	317.5	255.7	167.6	184.6	288.8	242.5	294.3	253.5	291.0	229.3	196.8	342.8	257.9	342.8	257.9	337.3	251.3	72.2
78.7	168.7	310.9	246.9	163.1	165.3	282.2	235.9	286.6	244.7	277.8	220.5	176.4	328.5	249.1	328.5	249.1	324.1	242.5	78.7
85.3	153.2	302.0	238.1	159.8	151.0	274.5	229.3	277.8	235.9	267.9	213.8	160.4	316.4	242.5	316.4	242.5	310.9	234.8	85.3
91.9	140.0	291.0	231.5	155.4	136.7	266.8	222.7	269.0	229.3	257.9	207.2	144.4	304.2	233.7	304.2	233.7	297.6	227.1	91.9
98.4	127.9	280.0	224.9	152.1	125.1	259.0	216.1	261.2	222.7	249.1	200.6	132.8	293.2	227.1	293.2	227.1	286.6	221.0	98.4
111.5	108.6	260.9	211.6	145.5	104.8	244.7	203.6	245.8	210.9	231.5	189.6	111.4	273.4	215.3	273.4	215.3	266.8	208.9	111.5
124.7	91.8	244.0	199.9	139.6	88.9	231.9	192.5	231.5	199.9	216.4	179.3	94.0	256.5	204.3	256.5	204.3	250.2	197.9	124.7
137.8	77.4	229.3	189.6	134.5	74.5	219.4	183.0	218.3	189.6	203.9	169.8	78.7	240.3	194.0	240.3	194.0	235.2	188.1	137.8
150.9	65.2	217.5	180.8	129.3	62.6	206.9	174.9	206.5	180.8	192.9	161.7	66.1	228.5	185.9	228.5	185.9	220.5	178.6	150.9
164.0	53.8	206.1	172.7	124.9	51.4	195.5	167.6	195.8	172.3	183.0	154.3	54.2	217.2	178.2	217.2	178.2	210.2	171.2	164.0
177.2	43.2	195.1	165.3	121.3	41.0	185.2	160.9	186.3	164.2	174.2	147.7	43.0	206.1	170.9	206.1	170.9	200.3	164.2	177.2
190.3	35.1	186.3	158.7	117.6	32.9	177.8	155.1	178.2	157.6	166.1	141.8	34.3	197.3	164.2	197.3	164.2	190.7	157.6	190.3
203.4	27.8	178.2	152.9	114.3	25.6	170.5	149.2	170.5	151.8	158.7	136.7	26.5	188.9	158.4	188.9	158.4	181.9	151.8	203.4
216.5	21.2	170.9	147.7	111.3	19.2	163.1	143.3	163.1	146.6	152.1	132.3	19.6	180.8	153.2	180.8	153.2	174.2	146.6	216.5
229.7	15.9	164.2	142.6	109.3	13.9	156.5	138.9	157.3	142.2	146.4	127.9	14.0	174.2	148.1	174.2	148.1	167.6	142.2	229.7
242.8	10.9	158.2	138.2	107.2	8.9	151.0	134.5	151.4	137.8	141.1	123.8	8.8	167.6	143.5	167.3	143.7	161.7	137.8	242.8
246.1	9.8	156.8	137.3	106.7	7.7	149.9	133.4	149.9	136.7	140.0	122.9	-	166.2	142.6	166.0	142.7	160.2	136.7	246.1
249.3	8.6	155.4	136.5	106.2	-	148.4	132.3	148.4	135.6	138.9	122.0	-	164.8	141.8	164.7	141.8	158.7	135.6	249.3
255.9	-	153.2	134.5	105.2	-	145.5	130.1	145.5	133.4	136.7	120.2	-	162.0	140.0	162.0	140.0	156.2	133.7	255.9
269.0	-	148.1	130.8	103.5	-	141.1	127.1	141.1	129.7	132.3	117.2	-	156.9	136.3	156.9	136.3	151.0	130.1	269.0
282.2	-	143.7	127.5	102.1	-	137.1	124.2	137.1	126.4	128.2	114.3	-	152.1	133.0	152.1	133.0	146.6	127.1	282.2
285.4	-	142.7	126.8	101.6	-	136.1	123.5	136.1	125.7	127.3	113.5	-	151.0	132.3	151.0	132.3	145.5	126.4	285.4
295.3	-	140.0	124.6	-	-	133.4	121.3	133.4	123.5	124.6	111.3	-	147.7	130.1	147.7	130.1	142.6	124.6	295.3
308.4	-	134.1	122.4	-	-	129.7	119.0	129.7	121.3	121.6	110.0	-	142.6	127.9	141.8	127.9	138.9	122.4	308.4
321.5	-	127.5	120.2	-	-	124.9	116.8	124.2	119.0	117.9	108.5	-	136.0	126.8	134.8	126.8	131.5	121.3	321.5
324.8	-	125.7	78.5	-	-	123.5	-	122.4	49.2	116.8	-	-	133.9	-	132.8	-	129.7	-	324.8
334.6	-	120.2	-	-	-	119.0	-	116.8	-	111.3	-	-	127.9	-	126.8	-	124.6	-	334.6

0 lb | 143,300 lb | 209,500 lb | 275,600 lb | 363,800 lb | 452,000 lb | 584,300 lb | 716,600 lb

LSL+LF_2 – LSL+LF_6: 36.1 ft – 62.3 ft

LSL+LF_8 – LSL+LF_10: 36.1 ft – 68.9 ft

LSL+LF_14: 42.7 ft – 68.9 ft

LSL+LF_14: 496,100 lb + 110,200 lb

Operation

LSL+LF

363,800 lb + 110,200 lb 36.1-68.9 ft 27.6 ft 32.2 ft/s 360° ASME B30.5																			
344.5 ft																			
LSL+LF_2 LSL+LF_3 LSL+LF_4 LSL+LF_6 LSL+LF_8 LSL+LF_10 LSL+LF_14																			
39.4 ft																			
0 lb 0-716.6 klb 0 lb 0-716.6 klb 0 lb 0-716.6 klb 0 lb 0-716.6 klb																			
15° 20° 30° 15° 20° 15° 20° 15° 20° 15° 20° 15° 20° 15° 20°																			
ft	1,000 lb														ft				
49.2	-	-	-	-	-	-	262.4	299.8	-	335.1	-	284.4	388.0	-	392.4	-	392.4	-	49.2
52.5	-	-	-	-	-	-	246.9	297.6	271.2	335.1	257.9	266.8	388.0	288.8	392.4	288.8	392.4	282.2	52.5
59.1	-	-	-	-	-	-	219.4	291.0	266.8	321.9	249.1	235.9	377.0	277.8	377.0	277.8	374.8	273.4	59.1
65.6	-	-	-	-	-	-	196.2	286.6	262.4	306.4	238.1	211.6	361.6	269.0	361.6	269.0	357.1	262.4	65.6
72.2	-	-	-	-	-	-	176.9	281.1	253.5	294.3	231.5	191.3	347.2	260.1	347.2	260.1	341.7	253.5	72.2
78.7	-	-	-	-	-	-	157.6	275.6	244.7	282.2	222.7	170.9	332.9	251.3	332.9	251.3	326.3	244.7	78.7
85.3	-	-	-	-	-	-	143.9	269.0	238.1	271.2	216.1	156.0	319.7	242.5	319.7	242.5	314.2	237.0	85.3
91.9	-	-	-	-	-	-	130.1	262.4	231.5	260.1	209.4	141.1	306.4	235.9	306.4	235.9	302.0	229.3	91.9
98.4	-	-	-	-	-	-	118.9	256.8	222.7	251.3	202.8	129.0	296.5	229.3	296.5	229.3	291.0	223.2	98.4
111.5	-	-	-	-	-	-	98.8	245.8	211.6	234.8	191.8	107.5	276.7	217.5	276.7	217.5	270.1	211.1	111.5
124.7	-	-	-	-	-	-	82.7	233.7	201.4	220.5	181.5	90.5	259.4	206.5	259.4	206.5	252.4	199.5	124.7
137.8	-	-	-	-	-	-	68.6	220.5	191.8	207.2	172.0	75.4	244.7	196.2	244.7	196.2	238.1	189.6	137.8
150.9	-	-	-	-	-	-	57.5	208.7	183.0	196.2	163.9	63.2	231.5	187.4	231.5	187.4	224.9	180.8	150.9
164.0	-	-	-	-	-	-	46.9	196.6	174.5	185.9	156.5	51.6	219.7	179.3	219.7	179.3	213.1	173.4	164.0
177.2	-	-	-	-	-	-	36.6	184.1	166.4	176.4	149.9	40.6	209.4	172.0	209.4	172.0	202.5	166.4	177.2
190.3	-	-	-	-	-	-	28.4	176.7	159.8	168.3	144.0	31.9	199.9	166.1	199.9	166.1	192.9	159.8	190.3
203.4	-	-	-	-	-	-	21.0	169.4	153.6	160.9	138.5	24.1	191.1	160.2	191.1	160.2	184.8	154.0	203.4
216.5	-	-	-	-	-	-	14.6	162.0	147.7	154.3	133.4	17.2	183.0	154.3	183.0	154.3	177.1	148.4	216.5
229.7	-	-	-	-	-	-	9.3	155.9	143.3	148.4	129.0	11.5	176.8	149.9	176.8	149.9	169.8	143.3	229.7
232.9	-	-	-	-	-	-	7.9	154.3	142.2	147.0	127.9	10.0	175.3	148.8	175.3	148.8	168.4	142.2	232.9
236.2	-	-	-	-	-	-	-	153.2	141.1	145.5	126.8	8.6	173.1	147.7	173.1	147.7	167.0	141.1	236.2
242.8	-	-	-	-	-	-	-	150.3	139.3	142.9	124.9	-	170.1	145.5	170.1	145.5	164.2	138.9	242.8
255.9	-	-	-	-	-	-	-	144.4	135.6	137.8	121.3	-	164.2	141.1	164.2	141.1	158.4	136.0	255.9
269.0	-	-	-	-	-	-	-	139.3	130.8	133.4	118.3	-	159.1	137.4	159.1	137.4	153.2	132.3	269.0
282.2	-	-	-	-	-	-	-	134.8	127.5	129.7	115.4	-	154.3	134.5	154.3	134.5	148.8	129.3	282.2
295.3	-	-	-	-	-	-	-	131.2	124.6	126.8	112.4	-	149.9	132.3	149.9	132.3	144.0	126.4	295.3
308.4	-	-	-	-	-	-	-	127.5	122.4	123.1	111.0	-	141.8	129.3	141.1	129.3	138.9	123.5	308.4
321.5	-	-	-	-	-	-	-	122.0	119.6	117.4	109.4	-	133.7	127.0	132.6	127.0	130.1	122.0	321.5
331.4	-	-	-	-	-	-	-	116.5	105.6	111.7	108.2	-	127.7	125.7	126.6	125.7	123.8	120.2	331.4
334.6	-	-	-	-	-	-	-	114.6	-	109.8	-	-	125.7	-	124.6	-	122.0	-	334.6
341.2	-	-	-	-	-	-	-	111.3	-	106.3	-	-	122.4	-	121.3	-	117.9	-	341.2

0 lb
 143,300 lb
 209,500 lb
 275,600 lb
 363,800 lb
 452,000 lb
 584,300 lb
 716,600 lb

LSL+LF_2 – LSL+LF_6: 36.1 ft – 62.3 ft





LSL+LF_8 – LSL+LF_10: 36.1 ft – 68.9 ft

LSL+LF_14: 42.7 ft – 68.9 ft

LSL+LF_14: 496,100 lb + 110,200 lb

Operation

LSL+LF

363,800 lb +  110,200 lb		 36.1-68.9 ft		 27.6 ft		 32.2 ft/s		360°		ASME B30.5										
354.3 ft																				
LSL+LF_2			LSL+LF_3			LSL+LF_4			LSL+LF_6			LSL+LF_8			LSL+LF_10			LSL+LF_14		
39.4 ft																				
0 lb			0-716.6 klb			0 lb			0-716.6 klb			0 lb			0-716.6 klb					
15°			20°			30°			15°			20°			15°			20°		
1,000 lb																				
ft	ft	ft	ft	ft	ft	ft	ft	ft	ft	ft	ft	ft	ft	ft	ft	ft	ft	ft		
49.2	264.6	304.2	-	-	-	-	310.9	-	328.5	-	277.8	377.0	-	390.2	-	392.4	-	49.2		
52.5	249.1	304.2	282.2	-	244.7	304.2	257.9	308.6	266.8	326.3	260.1	262.4	377.0	-	390.2	-	392.4	-	52.5	
55.8	234.8	304.2	280.0	-	231.5	303.1	256.8	307.5	265.7	325.2	254.6	246.9	375.9	284.4	385.8	284.4	384.7	277.8	55.8	
59.1	220.5	304.2	277.8	178.6	218.3	302.0	255.7	306.4	264.6	324.1	249.1	231.5	374.8	280.0	381.4	280.0	377.0	273.4	59.1	
65.6	198.4	302.0	269.0	173.1	195.1	299.8	251.3	304.2	260.1	308.6	240.3	207.2	363.8	271.2	363.8	271.2	359.4	264.6	65.6	
72.2	178.6	302.0	260.1	168.7	176.4	295.4	244.7	299.8	253.5	296.5	231.5	187.4	349.4	262.4	349.4	262.4	343.9	255.7	72.2	
78.7	160.9	299.8	251.3	165.3	157.6	291.0	238.1	295.4	246.9	284.4	224.9	167.6	335.1	253.5	335.1	253.5	330.7	246.9	78.7	
85.3	145.5	297.6	242.5	160.9	143.9	284.4	231.5	287.7	240.3	273.4	217.2	152.7	323.0	244.7	323.0	244.7	317.5	239.2	85.3	
91.9	132.3	293.2	235.9	157.6	130.1	277.8	224.9	280.0	233.7	262.4	210.5	137.8	310.9	238.1	310.9	238.1	304.2	231.5	91.9	
98.4	120.2	286.6	227.1	153.2	119.0	272.3	219.4	273.4	227.1	253.5	205.0	126.2	299.8	231.5	299.8	231.5	293.2	224.9	98.4	
111.5	101.6	267.5	215.3	147.3	99.1	260.1	207.6	260.1	215.3	237.0	193.3	105.1	280.0	219.7	280.0	219.7	273.4	212.7	111.5	
124.7	85.2	250.6	204.3	141.5	83.1	246.9	196.9	247.7	204.3	222.7	182.6	88.0	263.1	208.7	263.1	208.7	256.8	201.7	124.7	
137.8	71.0	235.9	194.0	135.6	69.0	233.7	187.4	235.9	194.0	209.4	173.1	73.0	246.9	198.4	246.9	198.4	241.8	191.8	137.8	
150.9	60.0	223.4	185.2	131.2	58.0	221.9	179.3	223.4	185.2	198.4	165.7	61.2	233.7	189.6	233.7	189.6	227.1	183.0	150.9	
164.0	49.2	212.0	176.7	127.1	47.3	209.8	172.0	210.5	176.7	188.1	158.4	49.9	221.9	181.5	221.9	181.5	216.1	174.9	164.0	
177.2	38.8	201.7	168.7	123.5	37.0	197.3	165.3	197.3	168.7	178.6	151.0	39.0	211.6	174.2	211.6	174.2	205.8	167.6	177.2	
190.3	30.6	192.2	162.8	119.8	29.0	188.5	158.7	189.2	162.0	170.5	145.1	30.4	202.8	167.6	202.8	167.6	196.2	160.9	190.3	
203.4	23.1	183.7	156.9	116.5	21.6	180.4	152.9	181.1	155.8	163.5	140.0	22.6	194.4	161.7	194.4	161.7	187.4	155.8	203.4	
216.5	16.5	176.4	151.0	113.5	15.0	173.1	147.7	173.1	149.9	156.5	135.6	15.7	186.3	156.5	186.3	156.5	179.7	150.6	216.5	
229.7	11.1	169.8	145.9	111.0	9.7	166.9	142.6	166.8	145.5	150.6	131.2	9.8	179.2	151.4	178.9	151.2	173.1	145.5	229.7	
232.9	9.7	168.1	144.6	110.4	8.4	165.3	141.3	165.0	144.4	149.2	130.1	8.4	177.5	150.1	177.1	149.9	171.4	144.4	232.9	
236.2	8.4	166.4	143.3	109.8	-	163.1	140.0	163.1	143.3	147.7	129.0	-	175.3	148.8	175.3	148.8	169.8	143.3	236.2	
242.8	-	163.5	141.5	108.7	-	160.2	138.2	160.2	141.5	145.1	127.1	-	172.3	147.0	172.3	147.0	166.4	141.1	242.8	
255.9	-	157.6	137.8	106.5	-	154.3	134.5	154.3	137.8	140.0	123.5	-	166.4	143.3	166.4	143.3	160.6	137.1	255.9	
269.0	-	152.5	134.1	104.7	-	149.2	129.7	149.2	134.1	135.6	119.8	-	161.3	139.6	161.3	139.6	155.4	133.4	269.0	
282.2	-	146.6	130.8	103.1	-	144.0	126.4	143.3	130.4	131.5	116.5	-	156.2	136.3	155.8	136.3	151.0	130.4	282.2	
295.3	-	140.0	127.9	101.6	-	138.9	123.5	136.7	126.8	127.9	113.5	-	151.0	133.4	149.9	133.4	145.1	127.5	295.3	
298.6	-	137.8	127.1	101.4	-	136.7	122.9	134.7	126.2	126.8	113.5	-	148.6	132.6	147.5	132.6	143.3	126.8	298.6	
308.4	-	131.2	124.9	-	-	130.1	121.3	128.6	124.6	123.5	111.8	-	141.5	130.4	140.4	130.4	137.8	124.6	308.4	
321.5	-	123.1	120.9	-	-	122.0	118.3	120.6	119.9	115.3	109.5	-	132.6	127.5	131.5	127.1	129.0	122.4	321.5	
334.6	-	115.7	115.7	-	-	114.6	114.6	112.4	112.4	107.8	108.0	-	124.6	124.6	123.5	123.5	120.2	121.3	334.6	
337.9	-	114.2	114.6	-	-	113.0	113.5	110.9	111.3	106.0	106.3	-	122.4	122.4	121.3	121.3	117.9	119.0	337.9	
341.2	-	112.7	78.3	-	-	111.3	-	109.3	61.9	104.3	-	-	120.2	-	119.6	-	115.7	-	341.2	
347.8	-	109.6	-	-	-	108.4	-	106.3	-	100.8	-	-	117.2	-	116.3	-	111.3	-	347.8	
351.1	-	107.8	-	-	-	106.9	-	104.7	-	99.0	-	-	115.7	-	114.6	-	110.0	-	351.1	

 0 lb 143,300 lb 209,500 lb 275,600 lb 363,800 lb 452,000 lb 584,300 lb 716,600 lb

LSL+LF_2 – LSL+LF_6:  36.1 ft – 62.3 ft

LSL+LF_8 – LSL+LF_10:  36.1 ft – 68.9 ft

LSL+LF_14:  42.7 ft – 68.9 ft

LSL+LF_14:  496,100 lb +  110,200 lb

Operation

LSL+LF

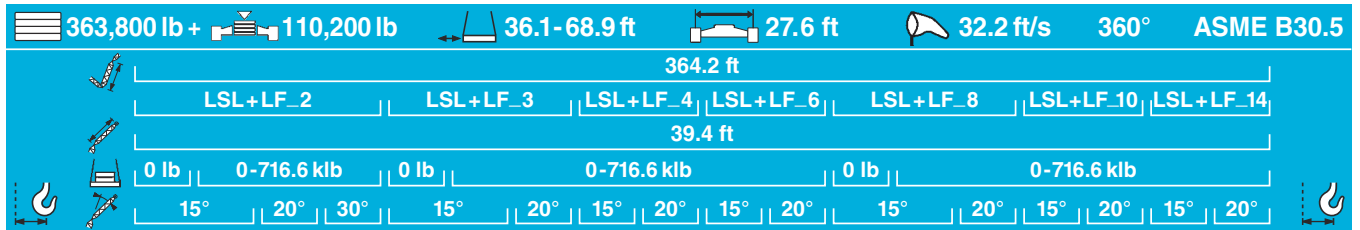

ft	1,000 lb																ft		
52.5	-	-	-	-	-	-	288.8	-	321.9	-	255.7	366.0	-	379.2	-	392.4	-	52.5	
55.8	-	-	-	-	224.9	297.6	253.5	287.7	262.4	321.9	255.7	241.4	366.0	286.6	379.2	286.6	385.8	280.0	55.8
59.1	-	-	-	-	212.7	297.6	253.5	286.6	260.1	321.9	251.3	227.1	366.0	280.0	379.2	280.0	379.2	275.6	59.1
65.6	-	-	-	-	189.6	295.4	249.1	284.4	260.1	310.9	242.5	202.8	363.8	271.2	366.0	271.2	361.6	264.6	65.6
72.2	-	-	-	-	171.4	293.2	246.9	281.1	253.5	298.7	233.7	183.0	350.5	262.4	351.6	262.4	346.1	255.7	72.2
78.7	-	-	-	-	153.2	291.0	240.3	277.8	246.9	286.6	224.9	163.1	337.3	253.5	337.3	253.5	332.9	249.1	78.7
85.3	-	-	-	-	139.4	285.5	233.7	272.3	242.5	275.6	219.4	148.3	325.2	246.9	325.2	246.9	320.8	241.4	85.3
91.9	-	-	-	-	125.7	280.0	227.1	266.8	235.9	264.6	212.7	133.4	313.1	240.3	313.1	240.3	308.6	233.7	91.9
98.4	-	-	-	-	115.0	273.4	220.5	260.1	229.3	255.7	206.1	121.8	303.1	233.7	303.1	233.7	297.6	227.1	98.4
111.5	-	-	-	-	95.5	261.2	210.2	250.2	216.8	239.2	195.1	101.1	283.3	221.2	283.3	221.2	276.7	214.4	111.5
124.7	-	-	-	-	79.7	249.9	199.9	238.8	205.8	224.9	184.8	84.4	266.0	210.2	266.0	210.2	259.0	203.4	124.7
137.8	-	-	-	-	65.7	238.1	189.6	227.1	196.2	211.6	175.3	69.4	251.3	200.6	251.3	200.6	244.7	194.0	137.8
150.9	-	-	-	-	54.8	226.3	181.5	215.3	187.4	200.6	167.2	57.8	238.1	191.8	238.1	191.8	231.5	185.2	150.9
164.0	-	-	-	-	44.5	214.6	174.2	203.9	179.3	190.3	159.8	46.9	226.0	183.7	226.0	183.7	219.7	177.1	164.0
177.2	-	-	-	-	34.6	202.8	167.6	192.9	172.0	180.8	153.2	36.6	215.0	176.4	215.0	176.4	208.7	169.8	177.2
190.3	-	-	-	-	26.5	192.5	160.9	183.0	164.6	172.7	147.3	27.8	205.4	169.8	205.4	169.8	198.4	163.1	190.3
203.4	-	-	-	-	19.2	183.7	155.1	174.9	158.0	165.7	142.2	19.9	196.6	163.5	196.6	163.5	190.3	157.3	203.4
216.5	-	-	-	-	12.6	176.4	149.9	167.6	152.1	158.7	136.7	13.0	188.5	157.6	188.5	157.6	182.6	151.8	216.5
226.4	-	-	-	-	8.4	172.0	146.2	163.4	148.5	154.3	133.4	8.6	183.5	154.3	183.5	154.3	177.1	147.9	226.4
229.7	-	-	-	-	-	170.1	144.8	161.8	147.2	152.9	132.3	-	181.9	153.2	182.1	153.2	175.3	146.6	229.7
242.8	-	-	-	-	-	163.5	140.0	155.8	142.6	147.3	128.2	-	175.3	148.8	175.3	148.8	168.4	142.2	242.8
255.9	-	-	-	-	-	157.6	135.6	149.9	138.9	142.2	124.6	-	168.7	144.4	168.7	144.4	162.8	138.2	255.9
269.0	-	-	-	-	-	152.5	131.9	144.8	135.2	137.8	120.9	-	163.5	140.7	163.5	140.7	157.6	134.5	269.0
282.2	-	-	-	-	-	145.5	128.6	140.0	131.5	133.7	117.9	-	156.9	137.4	156.9	137.4	152.5	131.5	282.2
295.3	-	-	-	-	-	136.7	125.7	135.6	127.9	130.1	115.7	-	148.8	134.5	147.7	134.5	145.1	128.6	295.3
308.4	-	-	-	-	-	127.9	122.7	126.8	124.2	121.3	112.4	-	139.3	131.5	138.2	131.5	135.6	125.7	308.4
321.5	-	-	-	-	-	119.6	118.6	117.9	117.9	113.0	109.4	-	130.1	127.9	129.0	127.3	124.6	123.9	321.5
334.6	-	-	-	-	-	112.4	112.4	110.2	111.3	105.4	105.6	-	122.4	122.4	121.3	121.3	116.0	118.2	334.6
347.8	-	-	-	-	-	106.0	106.3	103.8	104.3	98.2	98.1	-	115.0	114.6	113.8	113.5	107.8	109.8	347.8
357.6	-	-	-	-	-	101.0	-	99.0	-	93.0	-	-	109.8	-	108.2	-	102.1	-	357.6



LSL+LF_2 – LSL+LF_6: 36.1 ft – 62.3 ft





LSL+LF_8 – LSL+LF_10: 36.1 ft – 68.9 ft

LSL+LF_14: 42.7 ft – 68.9 ft

LSL+LF_14: 496,100 lb + 110,200 lb

Operation

LSL+LF

363,800 lb +  110,200 lb		 36.1-68.9 ft		 27.6 ft		 32.2 ft/s		360°		ASME B30.5											
374.0 ft																					
LSL+LF_2		LSL+LF_3		LSL+LF_4		LSL+LF_6		LSL+LF_8		LSL+LF_10		LSL+LF_12		LSL+LF_14							
39.4 ft																					
0 lb		0-716.6 klb		0 lb		0-716.6 klb		0 lb		0-716.6 klb		0 lb		0-716.6 klb							
15°		20°		30°		15°		20°		15°		20°		15°							
1,000 lb																					
ft	238.1	282.2	-	-	-	-	293.2	-	319.7	-	251.3	352.7	-	363.8	-	374.8	-	392.4	-	52.5	
52.5	238.1	282.2	-	-	-	-	293.2	-	319.7	-	251.3	352.7	-	363.8	-	374.8	-	392.4	-	52.5	
55.8	225.4	282.2	264.6	-	220.5	288.8	249.1	292.1	253.5	319.7	255.7	237.0	352.7	286.6	363.8	286.6	374.8	286.6	386.9	282.2	55.8
59.1	212.7	282.2	264.6	-	209.4	288.8	249.1	291.0	253.5	319.7	251.3	222.7	352.7	282.2	363.8	282.2	374.8	282.2	381.4	275.6	59.1
62.3	201.2	282.2	264.6	176.4	197.9	288.8	248.0	291.0	252.4	316.4	246.9	211.1	352.7	277.8	362.7	277.8	372.6	277.8	373.7	271.2	62.3
65.6	189.6	282.2	264.6	174.2	186.3	288.8	246.9	291.0	251.3	313.1	242.5	199.5	352.7	273.4	361.6	273.4	374.8	273.4	366.0	266.8	65.6
72.2	169.8	282.2	262.4	169.8	168.7	287.7	244.7	289.9	249.1	300.9	235.9	180.2	347.2	264.6	351.6	264.6	356.0	264.6	350.5	257.9	72.2
78.7	153.2	280.0	253.5	166.4	151.0	286.6	242.5	288.8	246.9	288.8	227.1	160.9	341.7	255.7	341.7	255.7	341.7	255.7	335.1	249.1	78.7
85.3	138.9	277.8	244.7	162.0	137.2	281.1	235.9	284.4	242.5	278.9	220.5	146.1	329.6	249.1	329.6	249.1	329.6	249.1	323.0	241.4	85.3
91.9	125.7	275.6	238.1	158.7	123.5	275.6	229.3	280.0	238.1	269.0	213.8	131.2	317.5	240.3	317.5	240.3	317.5	240.3	310.9	233.7	91.9
98.4	113.5	273.4	231.5	155.4	112.8	270.1	222.7	274.5	231.5	259.0	207.2	120.0	306.4	233.7	306.4	233.7	306.4	233.7	299.8	228.2	98.4
111.5	95.5	267.5	219.0	148.8	93.4	259.0	210.9	264.6	219.0	241.4	196.2	99.5	286.6	222.7	286.6	222.7	286.6	222.7	280.0	216.6	111.5
124.7	79.4	257.2	207.6	142.9	77.7	247.7	199.9	254.3	208.0	227.4	186.3	82.8	269.7	212.0	269.7	212.0	269.7	212.0	262.4	205.6	124.7
137.8	65.5	242.5	197.3	137.8	63.9	235.9	189.6	242.5	198.4	215.0	177.5	68.1	253.5	201.7	253.5	201.7	253.5	201.7	246.9	195.8	137.8
150.9	54.6	229.3	188.5	133.4	53.1	223.4	180.8	230.0	189.6	203.2	169.4	56.7	240.3	192.9	240.3	192.9	240.3	192.9	233.7	186.3	150.9
164.0	44.4	217.5	180.4	129.0	42.9	209.8	172.7	217.5	181.5	192.9	161.7	45.9	228.5	184.8	228.5	184.8	228.5	184.8	221.9	178.9	164.0
177.2	34.8	207.2	173.1	124.6	33.5	195.1	165.3	207.2	174.2	184.1	154.3	35.7	218.3	177.5	218.3	177.5	218.3	177.5	211.3	172.0	177.2
190.3	26.6	197.7	166.4	120.9	25.3	178.6	159.5	196.6	166.8	176.0	148.4	27.0	208.7	171.6	208.7	171.6	208.7	171.6	201.7	165.3	190.3
203.4	19.2	188.9	160.2	117.6	17.9	169.0	152.9	188.5	160.2	168.0	143.3	19.2	198.0	165.7	199.9	165.7	199.9	165.7	192.9	159.5	203.4
216.5	12.6	180.8	154.3	114.6	11.5	160.9	147.7	181.9	154.3	160.9	137.8	12.1	190.7	159.8	191.8	159.8	191.8	159.8	185.0	154.0	216.5
223.1	9.6	177.8	152.1	113.5	8.6	156.1	145.5	178.1	152.1	158.0	135.6	9.2	186.3	157.6	187.8	157.6	188.1	157.4	181.4	151.4	223.1
226.4	8.2	176.4	151.0	113.0	-	154.5	144.4	176.6	151.0	156.5	134.5	7.7	184.4	156.3	186.1	156.3	186.3	156.1	179.7	150.1	226.4
229.7	-	174.5	149.5	112.4	-	153.0	143.3	175.0	149.9	155.1	133.4	-	182.4	154.9	184.3	154.9	184.5	154.8	177.5	148.8	229.7
242.8	-	167.9	144.4	110.2	-	146.2	138.9	168.3	145.5	149.5	129.3	-	175.6	149.9	177.8	149.9	177.8	149.9	170.9	144.4	242.8
255.9	-	162.0	140.0	108.0	-	141.1	134.5	160.9	141.1	144.4	125.7	-	169.8	145.5	172.0	145.5	172.0	145.5	165.0	140.4	255.9
269.0	-	155.4	136.3	106.1	-	137.4	130.4	153.6	137.4	140.0	122.7	-	162.4	141.8	166.1	141.8	164.6	141.8	159.8	136.7	269.0
282.2	-	147.0	133.0	104.4	-	134.5	127.5	144.8	134.1	134.8	119.8	-	155.1	138.5	157.6	138.5	155.4	138.5	153.2	133.0	282.2
295.3	-	136.7	130.1	102.7	-	132.3	124.6	134.5	131.2	129.0	116.8	-	147.7	135.6	146.6	135.6	144.4	135.6	144.8	129.7	295.3
308.4	-	127.9	125.7	101.5	-	125.7	122.4	125.7	125.3	119.4	113.9	-	138.2	132.6	137.1	132.6	135.6	132.6	134.5	126.8	308.4
315.0	-	123.5	123.5	87.5	-	122.4	121.3	121.3	122.4	114.6	112.4	-	133.4	131.2	132.3	131.2	131.2	131.2	129.3	126.0	315.0
321.5	-	119.6	119.6	-	-	118.7	118.3	117.3	117.9	110.9	109.3	-	129.5	128.4	127.9	128.2	126.8	126.8	124.2	124.2	321.5
334.6	-	112.4	112.4	-	-	111.3	111.3	110.2	110.2	103.4	103.2	-	121.3	121.3	120.2	120.2	117.9	117.9	114.9	117.0	334.6
347.8	-	105.5	105.7	-	-	104.7	104.9	103.3	103.5	96.3	95.6	-	113.9	113.9	113.0	113.1	110.7	110.9	106.5	108.5	347.8
354.3	-	102.1	102.3	-	-	101.4	101.6	99.9	100.1	92.8	91.9	-	110.2	110.2	109.3	109.6	107.1	107.4	102.7	104.7	354.3
357.6	-	100.5	89.5	-	-	99.8	66.4	98.3	66.4	91.2	-	-	108.6	-	107.6	-	105.4	-	100.8	-	357.6
360.9	-	98.9	-	-	-	98.2	-	96.8	-	89.6	-	-	106.9	-	105.9	-	103.6	-	99.0	-	360.9
367.5	-	95.7	-	-	-	95.0	-	93.7	-	86.4	-	-	103.6	-	102.5	-	100.3	-	95.5	-	367.5

 0 lb 143,300 lb 209,500 lb 275,600 lb 363,800 lb 452,000 lb 584,300 lb 716,600 lb

LSL+LF_2 – LSL+LF_6:  36.1 ft – 62.3 ft





LSL+LF_8 – LSL+LF_12:  36.1 ft – 68.9 ft

LSL+LF_14:  42.7 ft – 68.9 ft

LSL+LF_14:  496,100 lb +  110,200 lb

Operation

LSL+LF

363,800 lb +  110,200 lb		 36.1-68.9 ft		 27.6 ft		 32.2 ft/s		360°		ASME B30.5											
383.9 ft																					
LSL+LF_2		LSL+LF_3		LSL+LF_4		LSL+LF_6		LSL+LF_8		LSL+LF_10		LSL+LF_12		LSL+LF_14							
39.4 ft																					
0 lb		0-716.6 klb		0 lb		0-716.6 klb		0 lb		0-716.6 klb		0 lb		0-716.6 klb							
15°		20°		30°		15°		20°		15°		20°		15°							
1,000 lb																					
ft															ft						
52.5	-	-	-	-	-	-	284.4	-	308.6	-	244.7	341.7	-	352.7	-	363.8	-	392.4	-	52.5	
55.8	-	-	-	-	216.1	280.0	244.7	284.4	251.3	308.6	257.9	231.5	341.7	288.8	352.7	288.8	363.8	288.8	388.0	282.2	55.8
59.1	-	-	-	-	203.9	280.0	244.7	284.4	251.3	308.6	253.5	218.3	341.7	284.4	352.7	284.4	363.8	284.4	383.6	277.8	59.1
65.6	-	-	-	-	181.9	280.0	244.7	284.4	249.1	308.6	244.7	194.0	341.7	273.4	350.5	273.4	363.8	273.4	368.2	269.0	65.6
72.2	-	-	-	-	164.2	280.0	242.5	284.4	249.1	299.8	235.9	175.3	340.6	264.6	347.2	264.6	353.8	264.6	352.7	260.1	72.2
78.7	-	-	-	-	146.6	280.0	242.5	284.4	246.9	291.0	229.3	156.5	339.5	257.9	343.9	257.9	343.9	257.9	339.5	251.3	78.7
85.3	-	-	-	-	132.8	276.7	238.1	281.1	244.7	281.1	220.5	142.2	329.6	249.1	331.8	249.1	331.8	249.1	326.3	243.6	85.3
91.9	-	-	-	-	119.0	273.4	231.5	277.8	238.1	271.2	215.0	127.9	319.7	242.5	319.7	242.5	319.7	242.5	313.1	235.9	91.9
98.4	-	-	-	-	108.8	270.1	224.9	273.4	233.7	261.2	209.4	116.5	308.6	235.9	308.6	235.9	308.6	235.9	303.1	229.3	98.4
111.5	-	-	-	-	89.8	262.4	213.8	265.7	221.9	243.6	198.4	95.9	288.8	224.9	288.8	224.9	288.8	224.9	283.3	217.7	111.5
124.7	-	-	-	-	74.3	252.1	203.2	256.5	210.9	229.6	188.1	79.3	271.9	214.2	271.9	214.2	271.9	214.2	265.7	207.2	124.7
137.8	-	-	-	-	60.6	240.3	192.9	244.7	200.6	217.2	178.6	64.6	255.7	203.9	255.7	203.9	255.7	203.9	250.6	197.3	137.8
150.9	-	-	-	-	49.9	228.5	184.1	233.0	192.5	206.1	170.5	53.3	242.5	195.1	242.5	195.1	242.5	195.1	235.9	188.5	150.9
164.0	-	-	-	-	40.1	212.7	175.6	221.9	184.5	195.8	163.1	42.8	230.8	187.0	230.8	187.0	230.8	187.0	224.9	180.4	164.0
177.2	-	-	-	-	31.1	201.7	167.6	211.6	176.4	186.3	156.5	33.3	220.5	179.7	220.5	179.7	220.5	179.7	214.2	173.1	177.2
190.3	-	-	-	-	22.9	190.0	161.7	200.3	169.8	178.2	150.6	24.6	210.9	173.1	210.9	173.1	210.9	173.1	203.9	166.4	190.3
203.4	-	-	-	-	15.5	175.5	155.1	191.8	163.4	170.5	145.3	16.8	202.1	167.1	202.2	167.1	202.2	167.1	195.1	160.6	203.4
216.5	-	-	-	-	9.0	168.7	149.9	185.2	157.6	163.1	140.0	9.7	194.0	160.9	194.0	160.9	194.0	160.9	187.0	154.9	216.5
219.8	-	-	-	-	-	166.4	148.8	183.5	156.3	161.7	139.9	8.2	192.2	159.8	192.2	159.8	192.2	159.8	185.2	153.5	219.8
229.7	-	-	-	-	-	160.2	144.8	178.6	152.5	157.3	135.6	-	186.7	156.5	186.7	156.5	186.7	156.5	179.7	149.9	229.7
242.8	-	-	-	-	-	155.1	140.4	172.0	147.7	151.4	131.2	-	180.0	152.1	180.0	152.1	180.0	152.1	173.8	145.5	242.8
255.9	-	-	-	-	-	149.9	136.7	165.3	143.3	145.5	126.8	-	174.2	147.7	174.2	147.7	174.2	147.7	167.9	141.5	255.9
269.0	-	-	-	-	-	145.5	133.0	153.6	139.6	141.1	123.8	-	166.1	144.0	165.3	144.0	163.9	144.0	162.0	137.8	269.0
282.2	-	-	-	-	-	140.0	129.3	142.6	136.3	135.0	120.7	-	156.5	140.4	155.4	140.4	153.2	140.4	152.5	134.1	282.2
295.3	-	-	-	-	-	133.4	125.7	132.3	133.4	126.8	117.9	-	145.5	136.7	144.4	136.7	142.2	136.7	142.2	130.8	295.3
308.4	-	-	-	-	-	124.6	122.7	123.5	124.6	117.2	114.3	-	136.0	133.0	134.8	132.3	132.3	133.4	131.2	127.9	308.4
321.5	-	-	-	-	-	116.6	117.4	116.2	116.3	108.6	108.3	-	126.8	126.8	125.7	126.0	123.8	124.6	120.9	121.3	321.5
334.6	-	-	-	-	-	109.3	109.6	108.2	108.7	100.8	99.9	-	117.9	119.0	116.8	117.9	115.7	115.7	111.6	112.7	334.6
347.8	-	-	-	-	-	102.3	102.5	99.6	101.5	93.7	92.2	-	110.2	111.7	109.2	110.5	107.8	108.2	103.4	104.5	347.8
360.9	-	-	-	-	-	95.5	95.8	90.3	94.7	86.9	85.2	-	103.0	104.5	102.1	103.3	100.6	101.0	95.8	96.9	360.9
364.2	-	-	-	-	-	93.9	94.1	87.9	93.0	85.2	83.6	-	101.3	102.7	100.5	101.6	99.0	99.2	93.8	95.0	364.2
374.0	-	-	-	-	-	89.3	-	80.5	-	80.2	-	-	96.8	-	96.1	-	94.1	-	88.6	-	374.0
377.3	-	-	-	-	-	88.0	-	78.0	-	78.7	-	-	95.5	-	94.6	-	92.6	-	86.9	-	377.3

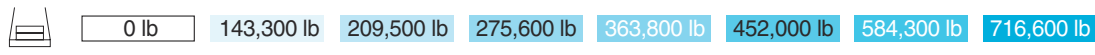

LSL+LF_2 – LSL+LF_6:  36.1 ft – 62.3 ft

LSL+LF_8 – LSL+LF_12:  36.1 ft – 68.9 ft

LSL+LF_14:  42.7 ft – 68.9 ft

LSL+LF_14:  496,100 lb +  110,200 lb

Operation

LSL+LF

363,800 lb +  110,200 lb		36.1-68.9 ft		27.6 ft		32.2 ft/s		360°		ASME B30.5																								
393.7 ft																																		
LSL+LF_2				LSL+LF_3				LSL+LF_4				LSL+LF_6				LSL+LF_8				LSL+LF_10				LSL+LF_12				LSL+LF_14						
39.4 ft																																		
0 lb				0-716.6 klb				0 lb				0-716.6 klb				0 lb				0-716.6 klb														
15°		20°		30°		15°		20°		15°		20°		15°		20°		15°		20°		15°		20°		15°		20°						
1,000 lb																																		
ft	1,000 lb																												ft					
52.5	229.3	251.3	-	-	-	-	-	273.4	-	297.6	-	-	-	-	-	-	-	-	-	-	-	-	-	-	-	-	-	-	-	52.5				
55.8	217.2	250.2	238.1	-	212.7	271.2	240.3	273.4	244.7	297.6	257.9	224.9	328.5	-	339.5	-	350.5	-	388.0	-	55.8													
59.1	205.0	249.1	238.1	-	199.5	271.2	240.3	273.4	244.7	297.6	253.5	213.8	328.5	284.4	339.5	284.4	350.5	284.4	388.0	277.8	59.1													
62.3	194.0	249.1	238.1	177.5	189.0	271.2	240.3	273.4	244.7	297.6	249.1	202.3	328.5	280.0	339.5	280.0	350.5	280.0	379.2	273.4	62.3													
65.6	183.0	249.1	238.1	175.3	178.6	271.2	240.3	273.4	244.7	297.6	244.7	190.7	328.5	275.6	339.5	275.6	350.5	275.6	370.4	269.0	65.6													
72.2	164.2	246.9	238.1	170.9	160.9	270.1	238.1	273.4	244.7	295.4	238.1	172.0	328.5	266.8	338.4	266.8	348.3	266.8	354.9	260.1	72.2													
78.7	147.7	246.9	238.1	167.6	143.3	269.0	238.1	273.4	244.7	293.2	229.3	153.2	328.5	257.9	337.3	257.9	346.1	257.9	341.7	253.5	78.7													
85.3	133.4	244.7	238.1	163.1	130.1	264.6	235.9	272.3	244.7	283.3	222.7	138.9	325.2	251.3	329.6	251.3	334.0	251.3	329.6	245.8	85.3													
91.9	120.2	242.5	235.9	159.8	116.8	260.1	229.3	271.2	240.3	273.4	217.2	124.6	321.9	244.7	321.9	244.7	321.9	244.7	317.5	238.1	91.9													
98.4	109.8	242.5	233.7	156.5	106.4	255.7	222.7	269.0	235.9	264.6	210.5	113.4	312.0	238.1	312.0	238.1	312.0	238.1	312.0	231.5	98.4													
111.5	91.6	239.6	222.7	150.6	87.3	245.8	212.4	265.7	224.1	246.9	199.5	93.1	292.1	226.3	292.1	226.3	292.1	226.3	285.5	219.4	111.5													
124.7	75.6	235.9	212.0	144.8	71.9	235.2	202.5	259.4	213.5	231.9	189.2	76.8	274.8	215.3	274.8	215.3	274.8	215.3	267.9	208.9	124.7													
137.8	61.9	231.5	201.7	138.9	58.2	224.9	192.9	249.1	203.9	219.4	179.7	62.4	260.1	205.0	260.1	205.0	260.1	205.0	252.8	199.2	137.8													
150.9	51.2	225.6	192.2	134.5	47.6	213.1	184.1	237.4	195.1	208.3	172.3	51.1	246.9	196.9	246.9	196.9	246.9	196.9	238.1	189.6	150.9													
164.0	41.4	214.2	183.7	130.4	38.1	201.4	176.0	226.0	186.7	198.0	165.0	40.9	234.4	188.9	234.4	188.9	234.4	188.9	226.3	182.2	164.0													
177.2	32.6	208.3	176.4	126.8	29.5	189.6	168.7	215.0	178.6	188.5	157.6	31.7	222.7	180.8	222.7	180.8	222.7	180.8	216.1	175.3	177.2													
190.3	24.3	196.9	169.8	123.1	21.3	172.0	162.0	203.9	172.0	180.4	152.1	22.9	213.1	174.9	213.1	174.9	213.1	174.9	207.2	168.7	190.3													
203.4	16.8	188.9	163.5	119.8	13.8	162.0	153.6	195.1	165.9	172.7	146.4	15.1	204.5	169.0	204.5	169.0	204.5	169.0	198.4	162.8	203.4													
213.3	11.8	181.3	159.1	117.6	8.8	156.9	146.1	190.1	161.5	167.2	142.4	9.9	197.3	164.6	198.4	164.6	198.4	164.6	191.8	158.4	213.3													
216.5	10.1	179.7	157.6	116.8	-	155.4	144.4	188.5	159.8	165.3	141.1	8.2	196.2	163.1	196.2	163.1	196.2	163.1	189.6	156.9	216.5													
219.8	8.6	178.2	156.5	116.1	-	152.5	143.1	186.8	158.5	163.9	140.0	-	194.4	161.9	194.4	161.9	194.4	161.9	187.7	155.4	219.8													
229.7	-	173.8	152.7	113.9	-	146.2	139.3	181.9	154.7	159.5	136.7	-	188.9	158.0	188.9	158.0	188.9	158.0	181.9	152.1	229.7													
242.8	-	167.2	147.7	111.4	-	140.7	132.3	173.8	149.9	153.6	132.6	-	182.2	153.2	182.2	153.2	182.2	153.2	176.0	147.0	242.8													
255.9	-	162.0	143.3	109.3	-	135.6	127.9	164.2	145.5	147.7	129.0	-	176.4	148.8	176.4	148.8	176.4	148.8	169.8	142.6	255.9													
269.0	-	154.0	139.6	107.3	-	130.1	123.8	152.5	141.8	142.6	125.3	-	166.1	145.1	165.3	145.1	163.9	145.1	163.1	138.9	269.0													
282.2	-	144.8	136.0	105.5	-	126.8	121.3	141.5	137.1	134.5	122.0	-	155.4	141.5	154.3	141.5	152.1	141.5	151.4	136.0	282.2													
295.3	-	134.5	132.3	103.8	-	124.6	119.0	131.2	131.2	124.6	119.0	-	144.4	137.8	143.3	137.8	141.1	137.8	139.4	132.7	295.3													
308.4	-	125.7	124.9	102.4	-	122.4	117.3	122.4	122.4	115.0	112.7	-	134.7	132.6	133.4	132.5	131.7	131.9	129.0	129.0	308.4													
321.5	-	117.3	118.2	101.2	-	115.2	113.8	113.5	114.1	106.7	105.2	-	125.3	126.0	124.2	124.6	122.4	122.4	118.7	119.4	321.5													
328.1	-	113.8	114.2	100.8	-	111.4	110.8	109.0	110.3	102.7	100.8	-	120.5	122.0	119.4	120.2	117.9	117.9	113.5	114.6	328.1													
334.6	-	110.2	110.2	-	-	107.6	107.8	104.5	106.5	98.8	96.6	-	115.7	117.9	114.6	115.7	113.5	113.5	109.5	110.5	334.6													
347.8	-	103.0	103.2	-	-	100.4	100.8	92.2	99.1	91.3	88.8	-	107.8	110.2	106.9	108.7	105.4	106.5	101.0	102.3	347.8													
360.9	-	96.2	96.5	-	-	93.7	94.0	80.2	86.6	84.0	81.5	-	100.3	102.7	99.6	101.7	98.1	99.5	93.3	94.7	360.9													
370.7	-	91.6	91.8	-	-	89.1	89.3	74.1	76.1	78.9	76.5	-	95.5	97.7	94.7	96.6	93.1	94.4	87.8	89.1	370.7													
374.0	-	90.2	90.4	-	-	87.5	87.9	72.1	73.0	77.2	-	-	93.9	-	93.0	-	91.5	-	86.1	-	374.0													
383.9	-	85.8	-	-	-	83.3	-	63.3	-	72.8	-	-	89.7	-	88.8	-	87.3	-	81.1	-	383.9													

 0 lb 143,300 lb 209,500 lb 275,600 lb 363,800 lb 452,000 lb 584,300 lb 716,600 lb

LSL+LF_2 – LSL+LF_6:  36.1 ft – 62.3 ft





LSL+LF_8 – LSL+LF_12:  36.1 ft – 68.9 ft

LSL+LF_14:  42.7 ft – 68.9 ft

LSL+LF_14:  496,100 lb +  110,200 lb

Operation

LSL+LF

363,800 lb +  110,200 lb		 36.1-68.9 ft		 27.6 ft		 32.2 ft/s		360°		ASME B30.5											
403.5 ft																					
LSL+LF_2		LSL+LF_3		LSL+LF_4		LSL+LF_6		LSL+LF_8		LSL+LF_10		LSL+LF_12		LSL+LF_14							
39.4 ft																					
0 lb		0-716.6 klb		0 lb		0-716.6 klb		0 lb		0-716.6 klb		0 lb		0-716.6 klb							
15°		20°		30°		15°		20°		15°		20°		15°							
1,000 lb																					
ft															ft						
55.8	-	-	-	-	-	264.6	-	284.4	-	220.5	315.3	-	326.3	-	339.5	-	374.8	-	55.8		
59.1	-	-	-	-	195.1	262.4	233.7	264.6	240.3	284.4	255.7	208.3	315.3	286.6	326.3	286.6	339.5	286.6	374.8	280.0	59.1
65.6	-	-	-	-	173.1	262.4	233.7	264.6	240.3	284.4	246.9	185.2	315.3	275.6	326.3	275.6	339.5	275.6	372.6	271.2	65.6
72.2	-	-	-	-	156.0	262.4	233.7	264.6	240.3	284.4	238.1	167.0	315.3	269.0	326.3	269.0	338.4	269.0	357.1	262.4	72.2
78.7	-	-	-	-	138.9	262.4	233.7	264.6	240.3	284.4	231.5	148.8	315.3	260.1	326.3	260.1	337.3	260.1	343.9	253.5	78.7
85.3	-	-	-	-	125.7	260.1	233.7	263.5	240.3	280.0	224.9	134.5	315.3	253.5	324.1	253.5	330.7	253.5	331.8	246.9	85.3
91.9	-	-	-	-	112.4	257.9	227.1	262.4	238.1	275.6	218.3	120.2	315.3	246.9	324.1	246.9	324.1	246.9	319.7	240.3	91.9
98.4	-	-	-	-	102.4	254.6	222.7	260.1	233.7	266.8	211.6	109.3	309.7	240.3	314.2	240.3	314.2	240.3	308.6	233.7	98.4
111.5	-	-	-	-	83.8	248.0	213.8	257.9	224.9	250.2	200.6	89.5	295.4	228.5	295.4	228.5	295.4	228.5	288.8	221.6	111.5
124.7	-	-	-	-	68.5	240.3	205.0	253.5	215.7	235.2	190.7	73.3	278.5	217.5	278.5	217.5	278.5	217.5	271.2	210.5	124.7
137.8	-	-	-	-	55.1	231.5	196.2	244.7	206.1	220.5	181.9	58.9	262.4	207.2	262.4	207.2	262.4	207.2	255.7	200.6	137.8
150.9	-	-	-	-	44.5	221.2	188.1	235.9	198.0	210.2	173.8	47.7	249.1	198.4	249.1	198.4	249.1	198.4	242.5	191.8	150.9
164.0	-	-	-	-	35.1	207.2	180.0	227.1	190.3	200.3	166.4	37.6	236.6	190.3	236.6	190.3	236.6	190.3	230.8	183.7	164.0
177.2	-	-	-	-	26.7	191.8	172.0	218.3	183.0	190.7	159.8	28.7	224.9	183.0	224.9	183.0	224.9	183.0	219.7	176.4	177.2
190.3	-	-	-	-	18.7	181.5	164.6	207.6	175.3	182.2	153.7	20.3	216.1	176.4	216.1	176.4	216.1	176.4	209.4	169.8	190.3
203.4	-	-	-	-	11.4	172.0	157.6	198.4	168.7	174.9	148.1	12.5	207.2	170.4	207.2	170.3	207.2	170.4	200.6	163.9	203.4
210.0	-	-	-	-	7.9	163.7	154.9	194.0	165.3	171.2	145.1	8.8	202.8	167.8	202.8	167.6	202.8	167.3	196.2	160.9	210.0
216.5	-	-	-	-	-	159.8	152.1	189.6	162.0	167.6	142.2	-	198.4	164.2	198.4	164.2	198.4	164.2	192.5	158.5	216.5
229.7	-	-	-	-	-	154.0	143.3	180.8	156.9	160.9	137.8	-	191.1	159.8	191.1	159.8	190.0	159.8	185.2	153.2	229.7
242.8	-	-	-	-	-	146.2	138.5	171.6	152.1	155.1	133.7	-	184.1	155.4	183.7	155.4	182.2	155.4	178.6	148.8	242.8
255.9	-	-	-	-	-	141.1	133.4	162.0	147.7	149.9	130.1	-	177.5	151.0	176.4	151.0	174.2	151.0	170.1	144.4	255.9
269.0	-	-	-	-	-	136.3	129.7	150.3	143.3	141.8	126.4	-	165.0	146.6	163.9	146.6	161.7	146.6	159.8	140.0	269.0
282.2	-	-	-	-	-	133.0	126.4	139.3	136.7	132.6	122.8	-	153.2	142.9	152.1	142.9	149.9	142.6	147.3	137.1	282.2
295.3	-	-	-	-	-	130.1	123.5	129.0	127.9	122.4	120.2	-	142.2	140.0	141.1	140.0	138.9	138.9	135.1	134.1	295.3
308.4	-	-	-	-	-	121.3	119.6	118.8	119.0	113.1	111.0	-	132.3	132.3	131.2	131.7	129.3	129.3	124.6	126.8	308.4
321.5	-	-	-	-	-	112.9	113.0	107.2	109.3	104.3	102.1	-	122.7	123.1	121.6	122.0	119.8	119.8	114.9	116.5	321.5
334.6	-	-	-	-	-	104.9	105.4	94.6	98.8	95.9	93.3	-	112.4	113.5	111.3	112.4	110.2	110.2	105.8	107.1	334.6
347.8	-	-	-	-	-	97.7	98.1	82.5	84.8	88.0	85.6	-	104.5	105.2	103.4	104.1	102.0	102.8	97.0	98.3	347.8
360.9	-	-	-	-	-	91.2	91.4	71.5	74.1	80.8	78.4	-	97.0	98.1	96.0	97.1	94.4	95.5	89.2	90.5	360.9
374.0	-	-	-	-	-	84.9	85.1	61.7	61.1	73.9	71.7	-	89.9	91.5	89.1	90.6	87.5	89.1	82.2	83.2	374.0
380.6	-	-	-	-	-	82.1	82.2	55.8	43.9	70.9	68.6	-	87.2	88.8	86.3	88.0	84.6	86.4	79.8	79.8	380.6
383.9	-	-	-	-	-	80.6	39.2	52.8	-	69.4	-	-	85.8	-	84.9	-	83.1	-	77.1	-	383.9
387.1	-	-	-	-	-	79.2	-	49.8	-	68.0	-	-	84.4	-	83.5	-	81.8	-	75.4	-	387.1
393.7	-	-	-	-	-	76.5	-	45.2	-	65.0	-	-	81.6	-	80.7	-	79.1	-	72.3	-	393.7

 0 lb 143,300 lb 209,500 lb 275,600 lb 363,800 lb 452,000 lb 584,300 lb 716,600 lb

LSL+LF_2 – LSL+LF_6:  36.1 ft – 62.3 ft





LSL+LF_8 – LSL+LF_12:  36.1 ft – 68.9 ft

LSL+LF_14:  42.7 ft – 68.9 ft

LSL+LF_14:  496,100 lb +  110,200 lb

Operation

LSL+LF

363,800 lb +  110,200 lb		 36.1-68.9 ft		 27.6 ft		 32.2 ft/s		360°		ASME B30.5											
413.4 ft																					
LSL+LF_2		LSL+LF_3		LSL+LF_4		LSL+LF_6		LSL+LF_8		LSL+LF_10		LSL+LF_12		LSL+LF_14							
39.4 ft																					
0 lb		0-716.6 klb		0 lb		0-716.6 klb		0 lb		0-716.6 klb											
15°		20°		30°		15°		20°		15°		20°		15°		20°					
1,000 lb																					
ft																					ft
55.8	209.4	218.3	-	-	-	-	-	238.1	-	266.8	-	219.4	293.2	-	304.2	-	332.9	-	368.2	-	55.8
59.1	198.4	218.3	212.7	-	195.1	235.9	231.5	238.1	231.5	266.8	255.7	206.1	293.2	284.4	304.2	286.6	332.9	286.6	368.2	280.0	59.1
65.6	176.4	217.2	211.6	176.4	174.2	235.9	229.3	238.1	229.3	266.8	246.9	184.1	293.2	277.8	304.2	277.8	332.9	277.8	366.0	271.2	65.6
72.2	158.7	216.1	211.6	172.0	157.1	234.8	229.3	237.0	229.3	266.8	240.3	165.9	293.2	269.0	304.2	269.0	331.8	269.0	359.4	262.4	72.2
78.7	143.3	216.1	210.5	167.6	140.0	233.7	229.3	235.9	229.3	266.8	231.5	147.7	293.2	262.4	304.2	262.4	330.7	262.4	346.1	255.7	78.7
85.3	129.0	215.0	210.5	164.2	127.3	232.6	227.1	234.8	227.1	266.8	224.9	133.9	293.2	253.5	303.1	253.5	329.6	253.5	334.0	248.0	85.3
91.9	116.8	212.7	209.4	160.9	114.6	231.5	227.1	233.7	224.9	266.8	219.4	120.2	293.2	246.9	302.0	246.9	328.5	246.9	321.9	240.3	91.9
98.4	106.0	211.6	207.2	157.6	104.5	230.4	224.9	231.5	224.9	263.5	213.8	109.3	292.1	240.3	302.0	240.3	317.5	240.3	310.9	233.7	98.4
111.5	88.1	209.1	204.3	151.8	86.0	228.2	221.9	228.2	221.2	252.4	202.8	89.6	289.9	228.5	295.4	228.5	297.6	228.5	291.0	222.1	111.5
124.7	72.5	206.5	200.6	146.2	70.9	224.9	218.6	224.9	217.2	237.4	192.5	73.6	279.3	217.9	280.7	217.9	280.7	217.9	274.5	212.2	124.7
137.8	59.1	202.8	196.2	141.1	57.5	220.5	215.0	220.5	212.7	222.7	183.0	59.3	264.6	208.3	264.6	208.3	264.6	208.3	259.4	202.5	137.8
150.9	48.5	198.4	191.1	136.7	47.1	216.1	210.5	215.3	206.9	212.4	174.9	48.3	251.3	200.3	251.3	200.3	251.3	200.3	244.7	192.9	150.9
164.0	39.0	193.6	185.6	132.3	37.8	209.4	203.2	205.4	198.0	202.5	167.6	38.3	238.8	192.2	238.8	192.2	238.8	192.2	233.0	185.6	164.0
177.2	30.6	188.5	179.7	127.9	29.5	205.0	196.2	198.4	190.7	192.9	160.9	29.3	227.1	184.1	227.1	184.1	227.1	184.1	221.9	178.6	177.2
190.3	22.6	180.8	171.2	124.2	21.5	197.3	188.1	191.4	184.1	184.1	155.1	21.1	218.3	178.2	218.3	178.2	218.3	178.2	211.6	172.0	190.3
203.4	15.1	172.6	165.6	121.0	14.1	189.6	181.4	185.7	174.7	176.8	149.7	13.4	209.4	172.3	209.4	172.3	209.7	172.3	202.8	165.3	203.4
213.3	10.1	168.7	160.9	119.0	9.0	185.2	177.5	179.1	170.3	171.5	145.7	7.9	203.4	167.9	203.4	167.9	203.7	167.9	196.6	160.8	213.3
216.5	8.4	166.4	159.8	117.9	-	184.1	176.4	175.3	168.7	169.8	144.4	-	201.7	166.4	201.7	166.4	201.7	166.4	194.7	159.5	216.5
229.7	-	158.4	150.3	115.2	-	176.7	167.9	169.4	160.2	163.1	139.3	-	194.4	161.3	194.0	161.3	194.4	161.3	187.4	154.3	229.7
242.8	-	152.1	144.0	112.4	-	171.2	160.9	161.7	155.4	157.3	134.8	-	186.7	156.5	186.3	156.5	184.8	156.5	180.8	149.9	242.8
255.9	-	147.7	138.9	110.2	-	165.3	156.5	156.5	151.0	152.1	131.2	-	178.6	152.1	177.5	152.1	173.1	152.1	171.2	145.9	255.9
269.0	-	142.2	136.0	108.5	-	153.6	150.6	149.9	146.2	144.8	127.5	-	165.3	147.7	164.2	147.7	159.8	147.7	158.7	142.2	269.0
282.2	-	137.8	132.3	106.7	-	142.6	142.9	141.8	140.4	136.0	124.2	-	153.2	144.0	152.5	144.0	147.7	143.3	146.2	138.5	282.2
295.3	-	133.4	130.1	104.9	-	132.3	133.4	132.3	132.3	125.7	121.3	-	142.2	141.1	142.2	141.1	136.7	137.8	134.8	133.4	295.3
308.4	-	124.6	123.9	103.5	-	123.5	123.7	123.5	123.5	116.1	114.6	-	132.3	133.4	132.3	132.3	127.1	127.5	124.6	124.6	308.4
321.5	-	116.2	116.3	102.1	-	115.2	116.1	115.1	115.2	107.5	107.3	-	123.1	124.2	123.1	123.1	117.9	117.9	114.9	115.0	321.5
334.6	-	108.2	108.7	101.0	-	107.6	108.0	107.1	107.6	99.6	99.0	-	113.5	114.6	113.5	113.5	109.1	109.3	105.6	105.8	334.6
344.5	-	103.0	103.3	80.2	-	102.3	102.6	101.9	102.2	94.2	93.1	-	107.5	108.5	107.3	107.7	102.7	103.2	99.0	99.2	344.5
347.8	-	101.2	101.5	-	-	100.5	100.8	100.1	100.4	92.4	91.2	-	105.5	106.4	105.2	105.8	100.6	101.1	96.8	97.0	347.8
360.9	-	94.5	94.7	-	-	93.8	93.8	93.4	93.6	85.6	83.9	-	97.8	98.8	97.6	98.4	92.7	93.6	88.8	89.1	360.9
374.0	-	88.2	88.4	-	-	87.5	86.9	87.1	87.3	79.4	77.2	-	90.6	91.9	90.4	91.5	85.5	86.9	81.6	81.9	374.0
387.1	-	82.6	82.8	-	-	79.1	78.5	81.5	81.7	73.2	71.0	-	84.7	86.2	84.5	86.0	79.8	81.4	74.5	75.0	387.1
390.4	-	81.2	81.4	-	-	77.1	-	80.1	80.2	71.7	-	-	83.3	-	83.0	-	78.4	-	73.0	-	390.4
400.3	-	77.2	-	-	-	70.1	-	76.3	-	67.5	-	-	79.4	-	78.9	-	74.5	-	68.6	-	400.3



LSL+LF_2 – LSL+LF_6:  36.1 ft – 62.3 ft

LSL+LF_8 – LSL+LF_12:  36.1 ft – 68.9 ft

LSL+LF_14:  42.7 ft – 68.9 ft

LSL+LF_14:  496,100 lb +  110,200 lb

Operation

LSL+LF

363,800 lb + 110,200 lb		36.1-68.9 ft		27.6 ft		32.2 ft/s		360°		ASME B30.5													
423.2 ft																							
LSL+LF_2		LSL+LF_3		LSL+LF_4		LSL+LF_6		LSL+LF_8		LSL+LF_10		LSL+LF_12		LSL+LF_14									
39.4 ft																							
0 lb		0-716.6 klb		0 lb		0-716.6 klb		0 lb		0-716.6 klb													
15°		20°		30°		15°		20°		15°		20°		15°		20°							
ft		1,000 lb																				ft	
55.8	-	-	-	-	-	-	227.1	-	255.7	-	213.8	282.2	-	293.2	-	319.7	-	354.9	-	55.8			
59.1	-	-	-	-	190.7	224.9	222.7	227.1	220.5	255.7	249.1	201.7	282.2	273.4	293.2	284.4	319.7	286.6	354.9	282.2	59.1		
65.6	-	-	-	-	169.8	224.9	220.5	227.1	220.5	253.5	249.1	179.7	282.2	273.4	293.2	277.8	319.7	277.8	354.9	273.4	65.6		
72.2	-	-	-	-	153.2	223.8	220.5	226.0	220.5	253.5	240.3	161.5	282.2	271.2	293.2	271.2	319.7	271.2	354.9	264.6	72.2		
78.7	-	-	-	-	136.7	222.7	220.5	224.9	220.5	253.5	233.7	143.3	282.2	262.4	293.2	262.4	319.7	262.4	348.3	255.7	78.7		
85.3	-	-	-	-	124.0	222.7	220.5	223.8	220.5	253.5	227.1	130.1	282.2	255.7	292.1	255.7	318.6	255.7	336.2	249.1	85.3		
91.9	-	-	-	-	111.3	222.7	219.4	222.7	219.4	253.5	220.5	116.8	282.2	249.1	291.0	249.1	317.5	249.1	324.1	242.5	91.9		
98.4	-	-	-	-	101.1	221.6	218.3	222.7	218.3	252.4	215.0	105.9	281.1	242.5	291.0	242.5	313.1	242.5	314.2	235.9	98.4		
111.5	-	-	-	-	82.6	218.8	215.3	221.6	214.6	249.1	203.9	86.1	278.9	230.8	288.8	230.8	299.8	230.8	294.3	223.8	111.5		
124.7	-	-	-	-	67.7	217.2	212.4	219.0	211.3	239.6	194.0	70.1	272.6	220.1	280.0	220.1	282.9	220.1	276.7	213.3	124.7		
137.8	-	-	-	-	54.5	215.0	209.4	216.1	208.3	224.9	185.2	56.0	266.8	210.5	266.8	210.5	266.8	210.5	261.6	203.9	137.8		
150.9	-	-	-	-	44.2	211.3	205.8	211.6	203.9	214.6	177.1	45.0	252.1	201.7	253.5	201.7	253.5	201.7	246.9	195.1	150.9		
164.0	-	-	-	-	34.8	205.4	199.9	203.9	197.3	204.7	169.4	35.1	241.8	193.6	241.8	193.6	241.8	193.6	235.2	187.0	164.0		
177.2	-	-	-	-	26.5	201.7	196.2	199.5	192.9	195.1	162.0	26.2	231.5	186.3	231.5	186.3	231.5	186.3	224.1	179.7	177.2		
190.3	-	-	-	-	18.8	195.1	190.3	192.9	184.5	186.3	156.5	18.4	221.2	179.7	221.2	179.7	221.2	179.7	213.8	173.1	190.3		
203.4	-	-	-	-	11.6	189.2	186.3	188.5	178.9	178.6	150.6	10.7	211.6	173.6	211.6	173.4	212.0	173.4	205.0	166.4	203.4		
206.7	-	-	-	-	9.9	188.5	185.2	185.2	177.5	176.9	149.4	8.8	209.4	172.2	209.7	172.0	210.0	172.0	202.8	165.3	206.7		
210.0	-	-	-	-	8.2	187.4	181.5	184.1	176.0	175.3	148.1	-	207.6	170.9	207.8	170.5	208.0	170.5	200.6	164.2	210.0		
216.5	-	-	-	-	-	185.2	177.5	181.9	173.1	172.0	145.5	-	203.9	167.6	203.9	167.6	203.9	167.6	196.9	161.7	216.5		
229.7	-	-	-	-	-	178.6	171.6	174.5	166.8	165.3	141.1	-	196.6	162.4	196.6	162.4	196.6	162.4	189.6	156.5	229.7		
242.8	-	-	-	-	-	172.0	166.4	169.0	160.2	159.1	136.7	-	187.4	157.6	187.0	157.6	185.6	157.6	180.8	151.4	242.8		
255.9	-	-	-	-	-	163.1	162.0	163.1	156.5	153.2	132.3	-	176.4	153.2	175.3	153.2	170.9	153.2	169.0	147.0	255.9		
269.0	-	-	-	-	-	151.4	151.8	151.4	149.2	143.7	128.6	-	163.1	149.5	162.0	149.5	157.6	149.5	154.3	143.3	269.0		
282.2	-	-	-	-	-	140.4	141.5	140.4	140.4	133.2	125.0	-	151.0	145.5	149.9	145.1	145.5	145.5	142.2	139.8	282.2		
295.3	-	-	-	-	-	130.1	131.2	130.1	130.1	123.5	122.4	-	140.0	141.1	138.9	140.0	134.5	134.5	130.4	132.3	295.3		
308.4	-	-	-	-	-	121.3	121.8	121.3	121.3	114.1	113.4	-	130.5	130.6	129.3	130.5	124.2	124.9	120.2	121.3	308.4		
321.5	-	-	-	-	-	113.0	113.8	112.9	113.0	105.3	104.4	-	120.5	120.9	119.8	120.5	114.6	115.0	110.3	110.2	321.5		
334.6	-	-	-	-	-	105.2	105.6	104.9	105.4	97.2	95.9	-	110.2	111.3	110.2	110.2	105.6	105.8	101.6	102.1	334.6		
347.8	-	-	-	-	-	98.0	98.4	97.7	98.1	90.0	88.1	-	102.4	102.9	101.9	102.4	97.1	97.4	92.8	93.3	347.8		
360.9	-	-	-	-	-	91.2	90.5	91.2	91.4	82.9	80.5	-	94.6	95.2	94.0	94.8	88.8	89.6	85.0	85.2	360.9		
374.0	-	-	-	-	-	84.9	82.0	84.9	85.1	76.1	73.9	-	87.1	88.2	86.6	87.7	81.8	82.7	77.6	77.9	374.0		
387.1	-	-	-	-	-	76.9	71.7	79.2	79.1	69.9	67.8	-	80.8	82.2	80.4	81.8	75.6	77.1	70.5	71.0	387.1		
397.0	-	-	-	-	-	69.2	45.4	75.3	74.7	65.5	63.5	-	76.8	78.3	76.1	77.8	71.3	73.2	65.9	66.4	397.0		
400.3	-	-	-	-	-	66.3	-	74.0	-	64.2	-	-	75.5	-	74.9	-	70.2	-	64.4	-	400.3		
410.1	-	-	-	-	-	57.5	-	70.3	-	60.2	-	-	71.7	-	71.2	-	66.6	-	60.2	-	410.1		

0 lb
 143,300 lb
 209,500 lb
 275,600 lb
 363,800 lb
 452,000 lb
 584,300 lb
 716,600 lb

LSL+LF_2 – LSL+LF_6: 36.1 ft – 62.3 ft





LSL+LF_8 – LSL+LF_12: 36.1 ft – 68.9 ft

LSL+LF_14: 42.7 ft – 68.9 ft

LSL+LF_14: 496,100 lb + 110,200 lb

Operation

LSL+LF

363,800 lb +  110,200 lb		 36.1-68.9 ft		 27.6 ft		 32.2 ft/s		360°		ASME B30.5											
433.1 ft																					
LSL+LF_2		LSL+LF_3		LSL+LF_4		LSL+LF_6		LSL+LF_8		LSL+LF_10		LSL+LF_12		LSL+LF_14							
39.4 ft																					
0 lb		0-716.6 klb		0 lb		0-716.6 klb		0 lb		0-716.6 klb											
15°		20°		30°		15°		20°		15°		20°		15°							
1,000 lb																					
ft															ft						
55.8	185.2	191.8	-	-	-	-	-	-	-	-	-	-	-	-	55.8						
59.1	185.2	190.7	187.4	-	186.3	217.2	212.7	218.3	212.7	240.3	235.9	197.3	271.2	-	280.0	-	308.6	-	343.9	-	59.1
62.3	176.9	190.7	186.8	-	176.4	216.6	212.2	217.7	212.7	240.3	235.9	186.3	271.2	262.4	280.0	273.4	308.6	284.4	343.9	277.8	62.3
65.6	169.8	190.7	186.3	169.8	166.4	216.1	211.6	217.2	212.7	240.3	235.9	175.3	271.2	262.4	280.0	273.4	308.6	280.0	343.9	273.4	65.6
72.2	152.1	189.6	185.2	168.7	149.9	215.5	211.6	216.6	211.6	240.3	235.9	157.6	271.2	262.4	280.0	271.2	308.6	271.2	343.9	264.6	72.2
78.7	136.7	188.5	185.2	168.7	133.4	215.0	210.5	216.1	210.5	240.3	233.7	140.0	271.2	262.4	280.0	264.6	308.6	264.6	343.9	257.9	78.7
85.3	123.5	187.4	184.1	165.3	120.9	214.4	209.4	215.0	209.4	239.2	227.1	126.8	269.0	255.7	280.0	255.7	306.4	255.7	335.1	250.2	85.3
91.9	111.3	185.2	181.9	162.0	108.5	213.8	208.3	215.0	209.4	238.1	220.5	113.5	269.0	249.1	280.0	249.1	304.2	249.1	326.3	242.5	91.9
98.4	101.4	184.1	180.8	158.7	98.3	212.7	207.2	213.8	208.3	238.1	216.1	103.0	267.9	242.5	280.0	242.5	304.2	242.5	316.4	237.0	98.4
111.5	83.9	181.9	178.6	152.9	80.0	210.0	205.0	211.6	205.4	237.0	205.0	83.6	265.7	232.2	277.8	232.2	298.7	232.2	296.5	226.0	111.5
124.7	68.6	180.0	176.4	147.3	65.3	206.9	202.1	209.1	202.5	233.0	195.1	67.8	262.4	221.9	271.2	221.9	285.1	221.9	278.9	215.0	124.7
137.8	55.3	178.6	174.2	142.2	52.2	203.9	198.4	206.1	199.5	227.1	186.3	53.8	257.9	211.6	262.4	211.6	269.0	211.6	263.8	205.0	137.8
150.9	45.0	174.9	170.5	137.8	42.0	199.5	193.3	202.5	195.8	216.8	178.2	42.8	247.7	203.6	253.5	203.6	255.7	203.6	249.1	196.2	150.9
164.0	35.7	171.2	167.2	133.4	32.7	194.4	188.5	196.6	189.6	206.9	170.9	32.8	239.6	195.5	242.5	195.5	244.0	195.5	237.4	188.9	164.0
177.2	27.3	167.6	164.2	129.0	24.5	188.5	184.1	192.9	185.2	197.3	164.2	24.0	233.7	187.4	233.7	187.4	233.7	187.4	226.7	181.5	177.2
190.3	19.8	163.9	160.6	126.0	17.1	182.6	175.6	186.3	178.6	188.5	157.6	16.5	223.4	180.8	223.4	180.8	223.1	181.2	217.2	174.2	190.3
203.4	12.6	157.6	154.3	122.9	9.9	177.5	170.9	180.8	174.2	180.4	151.8	9.0	215.0	175.3	215.0	175.3	215.0	174.9	207.6	168.3	203.4
206.7	10.8	156.5	153.2	122.1	8.2	176.1	167.0	178.9	173.1	178.6	150.5	-	212.7	173.9	212.7	173.9	212.7	173.6	205.8	166.8	206.7
210.0	9.0	155.4	152.1	121.3	-	174.7	164.8	178.0	172.0	176.7	149.2	-	210.5	172.5	210.5	172.5	210.5	172.3	203.9	165.3	210.0
216.5	-	153.2	149.9	119.0	-	172.0	162.0	176.4	169.8	173.1	146.6	-	206.1	169.8	206.1	169.8	206.1	169.8	199.9	162.8	216.5
229.7	-	147.3	143.3	116.8	-	164.6	155.4	169.8	162.0	167.2	142.2	-	198.8	164.6	198.8	164.6	196.6	164.6	191.8	157.6	229.7
242.8	-	141.8	138.9	114.3	-	157.6	150.6	164.2	155.8	161.3	137.8	-	188.1	159.5	188.1	159.5	184.1	159.5	180.0	153.2	242.8
255.9	-	137.8	134.5	111.3	-	153.2	145.5	159.8	152.1	155.4	133.4	-	174.2	154.3	174.2	154.3	168.7	154.3	166.8	148.8	255.9
269.0	-	134.1	129.7	109.6	-	147.3	140.0	148.8	147.0	143.1	129.7	-	161.7	150.6	160.9	150.6	156.2	150.6	152.1	144.4	269.0
282.2	-	131.2	126.4	107.8	-	139.3	134.5	138.2	139.3	131.5	125.3	-	149.9	145.5	149.0	145.5	144.0	144.8	139.6	141.1	282.2
295.3	-	129.0	123.5	106.0	-	129.0	127.9	127.9	129.0	121.3	120.2	-	138.9	138.9	137.8	138.9	133.4	133.4	128.2	130.8	295.3
308.4	-	121.8	120.9	104.4	-	120.2	117.7	119.0	120.2	111.9	111.2	-	128.6	128.6	128.2	128.6	123.1	123.1	117.9	119.0	308.4
321.5	-	113.8	114.0	103.0	-	111.6	107.1	110.7	111.6	103.3	102.4	-	118.6	118.8	118.5	118.6	113.4	113.4	108.0	109.0	321.5
334.6	-	105.6	106.0	101.6	-	103.4	96.6	103.0	103.4	95.2	93.7	-	108.9	109.3	108.7	108.9	103.8	103.8	99.3	100.1	334.6
347.8	-	98.4	98.8	97.8	-	95.2	85.8	95.7	96.1	88.0	86.1	-	100.2	100.7	100.0	100.4	95.2	95.5	90.6	91.3	347.8
360.9	-	91.6	92.1	59.1	-	85.4	75.5	89.0	89.4	81.0	78.7	-	92.2	92.9	91.9	92.5	87.0	87.3	82.8	83.3	360.9
374.0	-	85.3	85.8	-	-	74.1	64.6	82.7	82.9	74.1	71.7	-	84.9	85.5	84.4	85.3	79.6	80.5	75.5	75.8	374.0
387.1	-	79.7	80.0	-	-	62.7	53.9	77.1	76.7	67.8	65.6	-	78.4	79.5	78.1	79.3	73.3	74.6	68.6	68.8	387.1
400.3	-	74.4	74.6	-	-	51.4	43.0	71.9	70.9	61.9	59.7	-	72.6	74.0	72.4	73.8	67.5	69.2	62.3	62.6	400.3
403.5	-	73.2	73.4	-	-	48.6	40.1	70.7	69.5	60.5	58.4	-	71.3	72.8	71.1	72.5	66.3	67.9	60.8	61.1	403.5
406.8	-	71.9	72.1	-	-	45.8	-	69.4	68.1	59.2	-	-	70.0	-	69.8	-	65.0	-	59.3	-	406.8
410.1	-	70.7	32.0	-	-	43.0	-	68.2	-	57.8	-	-	68.7	-	68.5	-	63.7	-	57.9	-	410.1
413.4	-	69.4	-	-	-	40.1	-	67.0	-	56.4	-	-	67.5	-	67.2	-	62.6	-	56.5	-	413.4
419.9	-	67.2	-	-	-	34.4	-	64.6	-	54.0	-	-	65.3	-	65.0	-	60.4	-	53.8	-	419.9

 0 lb 143,300 lb 209,500 lb 275,600 lb 363,800 lb 452,000 lb 584,300 lb 716,600 lb

LSL+LF_2 – LSL+LF_6:  36.1 ft – 62.3 ft





LSL+LF_8 – LSL+LF_12:  36.1 ft – 68.9 ft

LSL+LF_14:  42.7 ft – 68.9 ft

LSL+LF_14:  496,100 lb +  110,200 lb

Operation

LSL+LF

363,800 lb +  110,200 lb		 36.1-68.9 ft		 27.6 ft		 32.2 ft/s		360°		ASME B30.5											
442.9 ft																					
LSL+LF_2		LSL+LF_3		LSL+LF_4		LSL+LF_6		LSL+LF_8		LSL+LF_10		LSL+LF_12		LSL+LF_14							
39.4 ft																					
0 lb		0-716.6 klb		0 lb		0-716.6 klb		0 lb		0-716.6 klb		0 lb		0-716.6 klb							
15°		20°		30°		15°		20°		15°		20°		15°		20°					
1,000 lb																					
ft															ft						
59.1	-	-	-	-	-	208.3	-	227.1	-	191.8	257.9	-	269.0	-	295.4	-	326.3	-	59.1		
62.3	-	-	-	-	170.9	206.1	203.9	208.3	202.8	227.1	222.7	181.3	257.9	251.3	269.0	262.4	295.4	284.4	326.3	280.0	62.3
65.6	-	-	-	-	162.0	206.1	203.9	208.3	202.8	227.1	222.7	170.9	257.9	251.3	269.0	262.4	295.4	280.0	326.3	275.6	65.6
72.2	-	-	-	-	145.5	206.1	202.8	207.8	201.7	226.0	222.7	153.8	257.9	251.3	269.0	262.4	295.4	273.4	326.3	266.8	72.2
78.7	-	-	-	-	129.0	206.1	202.8	207.2	201.7	224.9	222.7	136.7	257.9	251.3	269.0	262.4	295.4	264.6	326.3	257.9	78.7
85.3	-	-	-	-	116.8	205.0	201.7	206.7	200.6	224.9	222.7	123.3	256.8	251.3	267.9	257.9	294.3	257.9	326.3	251.3	85.3
91.9	-	-	-	-	104.7	203.9	200.6	206.1	199.5	224.9	222.7	110.0	255.7	251.3	266.8	251.3	293.2	251.3	326.3	244.7	91.9
98.4	-	-	-	-	94.7	202.8	199.5	205.0	199.5	223.8	217.2	99.3	255.7	244.7	266.8	244.7	293.2	244.7	317.5	238.1	98.4
111.5	-	-	-	-	76.6	200.6	197.3	202.8	197.3	221.6	206.9	79.9	253.5	233.0	264.6	233.0	291.0	233.0	299.8	226.0	111.5
124.7	-	-	-	-	62.0	198.8	195.1	201.0	195.5	220.1	196.9	64.3	249.9	222.7	260.1	222.7	285.1	222.7	282.2	216.1	124.7
137.8	-	-	-	-	48.9	197.3	192.9	199.5	194.0	219.4	187.4	50.5	246.9	213.8	255.7	213.8	273.4	213.8	266.0	207.2	137.8
150.9	-	-	-	-	38.8	193.6	190.0	196.6	190.3	215.0	179.3	39.6	237.4	205.0	246.9	205.0	260.1	205.0	251.3	198.4	150.9
164.0	-	-	-	-	29.6	190.0	186.7	192.2	185.6	208.3	172.0	29.8	231.5	196.9	239.6	196.9	247.7	196.9	239.6	190.3	164.0
177.2	-	-	-	-	21.4	186.3	183.0	188.5	181.9	199.5	165.3	20.9	227.1	189.6	233.7	189.6	235.9	189.6	228.9	183.0	177.2
190.3	-	-	-	-	14.5	181.7	177.1	183.4	176.7	190.7	159.5	13.7	218.3	183.0	224.9	183.0	224.9	183.0	219.4	176.4	190.3
200.1	-	-	-	-	9.3	177.3	171.6	179.9	174.2	184.5	155.1	8.4	213.5	178.2	218.4	178.2	218.4	178.2	212.7	171.7	200.1
203.4	-	-	-	-	-	176.0	170.0	177.8	172.6	182.6	153.6	-	211.4	176.7	216.4	176.7	216.4	176.7	210.5	170.3	203.4
216.5	-	-	-	-	-	172.0	166.4	174.2	168.7	175.3	147.7	-	206.1	170.9	208.3	170.9	208.3	170.9	202.1	164.6	216.5
229.7	-	-	-	-	-	163.9	158.7	169.4	164.2	168.7	143.3	-	198.0	165.7	198.8	165.7	195.8	165.7	194.0	158.7	229.7
242.8	-	-	-	-	-	154.7	152.9	165.0	159.5	161.3	138.9	-	186.7	160.9	186.7	160.9	181.9	160.9	177.8	154.3	242.8
255.9	-	-	-	-	-	144.4	148.8	159.8	156.5	153.2	134.5	-	172.0	156.5	172.0	156.5	166.4	156.5	162.8	149.9	255.9
269.0	-	-	-	-	-	135.6	144.4	148.1	147.0	140.4	131.2	-	159.5	152.1	158.7	152.1	154.1	152.1	148.8	145.5	269.0
282.2	-	-	-	-	-	126.8	137.2	136.7	137.2	129.3	124.9	-	147.7	146.1	146.2	146.2	141.8	142.2	136.2	138.3	282.2
295.3	-	-	-	-	-	117.9	126.8	126.8	126.8	119.0	116.8	-	136.7	136.7	135.6	135.6	130.1	131.2	124.6	126.4	295.3
308.4	-	-	-	-	-	109.3	117.9	117.2	117.9	109.2	107.6	-	125.7	125.7	124.6	125.3	120.2	119.7	113.5	114.6	308.4
321.5	-	-	-	-	-	100.2	109.3	108.6	109.4	100.8	98.9	-	115.2	115.2	114.6	115.1	109.9	109.9	104.6	105.5	321.5
334.6	-	-	-	-	-	90.8	100.8	100.8	101.2	92.6	90.4	-	105.8	106.0	105.2	105.4	100.3	100.3	95.8	96.6	334.6
347.8	-	-	-	-	-	81.4	88.7	93.5	94.0	84.9	82.7	-	97.2	97.5	96.5	96.9	91.5	91.7	87.3	88.0	347.8
360.9	-	-	-	-	-	72.2	76.6	86.8	86.9	77.7	75.5	-	88.8	89.4	88.2	88.6	83.5	83.8	79.5	80.0	360.9
374.0	-	-	-	-	-	62.8	65.0	80.5	80.0	70.8	68.6	-	81.6	82.0	80.9	81.6	75.8	76.5	72.1	72.4	374.0
387.1	-	-	-	-	-	53.6	53.4	74.9	73.7	64.4	62.4	-	75.0	75.8	74.4	75.4	69.4	70.3	65.0	65.5	387.1
400.3	-	-	-	-	-	44.3	41.0	69.6	67.8	58.7	56.7	-	69.0	70.3	68.5	69.8	63.5	64.7	58.9	59.2	400.3
410.1	-	-	-	-	-	37.3	32.2	65.8	63.8	54.5	52.7	-	65.0	66.5	64.4	66.1	59.5	61.2	54.4	54.7	410.1
413.4	-	-	-	-	-	34.8	-	64.6	62.4	53.1	51.4	-	63.7	65.3	63.1	64.8	58.2	60.0	53.0	53.4	413.4
426.5	-	-	-	-	-	25.6	-	60.2	-	48.3	-	-	59.1	-	58.6	-	53.8	-	47.4	-	426.5

 0 lb 143,300 lb 209,500 lb 275,600 lb 363,800 lb 452,000 lb 584,300 lb 716,600 lb

LSL+LF_2 – LSL+LF_6:  36.1 ft – 62.3 ft

LSL+LF_8 – LSL+LF_12:  36.1 ft – 68.9 ft

LSL+LF_14:  42.7 ft – 68.9 ft

LSL+LF_14:  496,100 lb +  110,200 lb

Operation

LSL+LF

363,800 lb +  110,200 lb		36.1-68.9 ft		27.6 ft		32.2 ft/s		360°		ASME B30.5											
452.8 ft																					
LSL+LF_2		LSL+LF_3		LSL+LF_4		LSL+LF_6		LSL+LF_8		LSL+LF_10		LSL+LF_12		LSL+LF_14							
39.4 ft																					
0 lb		0-716.6 klb		0 lb		0-716.6 klb		0 lb		0-716.6 klb		0 lb		0-716.6 klb							
15°		20°		30°		15°		20°		15°		20°		15°		20°					
1,000 lb																					
ft	ft	ft	ft	ft	ft	ft	ft	ft	ft	ft	ft	ft	ft	ft	ft	ft	ft				
59.1	160.9	165.3	-	-	-	-	196.2	-	208.3	-	187.4	244.7	-	257.9	-	277.8	-	317.5	-	59.1	
62.3	159.8	165.3	162.0	-	172.0	179.7	175.3	196.2	196.2	207.2	203.9	177.5	244.7	240.3	257.9	253.5	277.8	271.2	317.5	280.0	62.3
65.6	159.8	165.3	160.9	-	162.0	179.7	175.3	196.2	196.2	207.2	203.9	167.6	244.7	240.3	257.9	253.5	277.8	271.2	317.5	275.6	65.6
68.9	153.2	164.2	160.4	149.9	154.3	179.1	174.7	196.2	196.2	207.2	203.9	159.0	244.2	240.3	257.9	253.5	277.8	271.2	317.5	271.2	68.9
72.2	147.7	163.1	159.8	148.8	146.6	178.6	174.2	196.2	196.2	207.2	203.9	150.5	243.6	240.3	257.9	253.5	277.8	271.2	317.5	266.8	72.2
78.7	132.3	162.0	158.7	148.8	131.2	177.5	173.1	196.2	196.2	207.2	202.8	133.4	242.5	240.3	257.9	253.5	277.8	266.8	317.5	260.1	78.7
85.3	120.2	162.0	157.6	147.7	118.8	176.4	172.0	196.2	196.2	206.1	202.8	120.3	241.4	238.1	256.8	253.5	276.7	260.1	317.5	253.5	85.3
91.9	108.2	160.9	157.6	147.7	106.5	175.3	170.9	196.2	196.2	205.0	201.7	107.1	240.3	238.1	255.7	251.3	275.6	253.5	317.5	246.9	91.9
98.4	97.9	159.8	156.5	146.6	96.7	173.6	169.8	196.2	196.2	203.9	201.7	96.6	239.2	235.9	255.7	246.9	275.6	246.9	314.2	240.3	98.4
111.5	80.8	156.9	153.6	145.1	78.8	170.9	167.6	196.2	195.5	201.7	198.8	77.4	237.0	231.5	253.5	235.2	274.5	235.2	302.0	228.2	111.5
124.7	65.8	154.0	151.0	143.3	64.4	168.7	165.0	196.2	194.4	199.5	194.4	61.9	234.4	224.5	249.9	224.5	271.2	224.5	284.4	217.7	124.7
137.8	52.9	152.1	148.8	141.1	51.6	166.4	162.0	196.2	192.9	197.3	188.5	48.1	231.5	215.0	246.9	215.0	266.8	215.0	269.0	208.3	137.8
150.9	42.6	149.2	145.9	138.2	41.4	162.8	159.1	193.3	189.2	193.6	180.4	37.3	227.1	206.1	239.6	206.1	255.0	206.1	255.7	199.5	150.9
164.0	33.4	145.9	142.9	134.8	32.3	159.1	155.8	189.2	185.9	189.6	173.1	27.6	222.7	198.0	230.8	198.0	245.4	198.0	245.4	191.4	164.0
177.2	25.4	142.2	140.0	131.2	24.3	155.4	152.1	185.2	183.0	185.2	166.4	19.0	218.3	190.7	224.9	190.7	238.1	190.7	230.8	184.1	177.2
190.3	18.2	139.3	137.1	127.5	17.3	152.5	149.2	181.9	177.3	179.7	160.6	11.8	213.8	184.5	220.5	184.5	227.1	184.1	220.5	177.5	190.3
196.9	14.6	137.8	135.6	125.7	13.9	151.0	147.7	178.6	176.4	177.5	157.6	8.2	211.6	180.8	218.3	180.8	222.7	180.8	216.4	174.8	196.9
203.4	11.0	136.0	134.5	124.2	10.4	146.8	144.8	175.3	170.1	174.2	155.1	-	209.4	178.1	212.7	177.8	218.6	177.8	212.4	171.7	203.4
206.7	9.3	135.4	133.7	123.5	8.6	145.9	143.6	173.6	169.2	173.1	153.8	-	208.3	176.6	211.6	176.4	216.6	176.4	210.4	170.2	206.7
216.5	-	133.4	131.2	120.2	-	143.3	141.1	170.9	166.4	169.8	149.9	-	205.0	172.0	208.3	172.0	210.5	172.0	202.5	166.1	216.5
229.7	-	128.2	126.0	117.9	-	138.5	137.4	165.7	159.8	164.2	144.8	-	194.7	166.8	196.6	166.8	197.3	166.8	190.7	160.9	229.7
242.8	-	123.8	122.4	115.4	-	135.2	132.6	161.3	153.6	159.8	140.4	-	183.0	162.0	183.7	162.0	183.0	162.0	175.3	155.8	242.8
255.9	-	120.2	117.9	112.4	-	132.3	129.0	157.6	149.9	155.4	136.7	-	169.8	157.6	169.8	157.6	167.6	157.6	160.5	151.4	255.9
269.0	-	117.2	115.0	110.5	-	127.1	124.9	145.9	144.0	144.4	132.3	-	157.3	153.2	157.3	153.2	155.1	152.5	146.6	147.7	269.0
282.2	-	113.0	111.6	108.5	-	124.2	121.8	135.6	136.0	133.4	128.8	-	144.4	145.1	145.5	145.5	142.9	144.0	134.1	136.2	282.2
295.3	-	110.2	109.8	105.4	-	120.2	117.9	124.6	125.7	122.4	123.5	-	133.4	133.4	133.4	134.5	131.2	132.3	122.4	124.0	295.3
308.4	-	108.2	106.8	103.6	-	117.2	112.8	115.7	116.1	113.4	114.1	-	123.1	123.1	123.1	123.5	121.6	122.0	111.3	112.4	308.4
321.5	-	106.1	104.9	101.7	-	111.6	105.7	107.1	107.4	104.9	105.1	-	112.8	112.8	112.4	112.4	112.0	112.1	102.7	103.6	321.5
334.6	-	104.1	103.2	100.5	-	103.4	98.3	99.0	99.4	96.8	96.8	-	103.6	103.8	103.4	103.6	102.3	102.5	94.1	94.8	334.6
347.8	-	96.9	96.9	96.4	-	94.9	91.0	91.8	92.2	89.6	89.1	-	94.9	95.3	94.7	95.1	93.5	93.8	85.8	86.4	347.8
360.9	-	90.1	90.5	91.1	-	86.4	83.6	85.0	85.4	82.7	81.8	-	86.8	87.3	86.6	87.0	85.2	85.8	78.1	78.6	360.9
374.0	-	83.8	84.0	73.9	-	78.0	76.1	78.7	79.1	76.5	75.0	-	79.4	80.0	78.9	79.6	77.6	78.3	70.8	71.1	374.0
387.1	-	78.0	78.3	-	-	69.5	68.7	73.1	73.4	70.6	68.8	-	72.8	73.6	72.3	73.3	71.1	71.9	63.9	64.2	387.1
400.3	-	72.7	73.0	-	-	61.0	61.4	67.8	68.0	64.8	62.8	-	66.6	67.7	66.1	67.4	64.8	66.0	57.6	58.0	400.3
413.4	-	67.7	67.9	-	-	53.1	54.0	62.8	63.1	59.3	57.3	-	61.1	62.6	60.6	62.2	59.5	60.8	51.7	52.0	413.4
419.9	-	65.5	65.7	-	-	48.7	50.3	60.5	60.7	56.8	54.9	-	58.8	60.2	58.3	60.0	57.2	58.6	48.9	49.2	419.9
426.5	-	63.3	26.0	-	-	44.4	-	58.3	49.2	54.3	-	-	56.5	-	56.1	-	55.0	-	46.3	-	426.5
436.4	-	60.0	-	-	-	38.1	-	55.1	-	50.7	-	-	53.1	-	52.9	-	51.8	-	42.5	-	436.4

 0 lb 143,300 lb 209,500 lb 275,600 lb **363,800 lb** 452,000 lb 584,300 lb 716,600 lb

LSL+LF_2 – LSL+LF_6:  36.1 ft – 62.3 ft





LSL+LF_8 – LSL+LF_12:  36.1 ft – 68.9 ft

LSL+LF_14:  42.7 ft – 68.9 ft

LSL+LF_14:  496,100 lb +  110,200 lb

Operation

LSL+LF

363,800 lb +  110,200 lb		 36.1-68.9 ft		 27.6 ft		 32.2 ft/s		360°		ASME B30.5											
462.6 ft																					
LSL+LF_2		LSL+LF_3		LSL+LF_4		LSL+LF_6		LSL+LF_8		LSL+LF_10		LSL+LF_12		LSL+LF_14							
39.4 ft																					
0 lb		0-716.6 klb		0 lb		0-716.6 klb		0 lb		0-716.6 klb		0 lb		0-716.6 klb							
15°		20°		30°		15°		20°		15°		20°		15°		20°					
1,000 lb																					
ft																					ft
59.1	-	-	-	-	-	-	-	196.2	-	198.4	-	183.0	233.7	-	242.5	-	264.6	-	304.2	-	59.1
62.3	-	-	-	-	166.4	172.0	168.7	196.2	194.0	198.4	195.1	172.5	233.7	-	242.5	-	264.6	-	304.2	-	62.3
65.6	-	-	-	-	157.6	172.0	168.7	196.2	194.0	198.4	195.1	162.0	233.7	229.3	242.5	240.3	264.6	260.1	304.2	275.6	65.6
72.2	-	-	-	-	142.2	170.9	167.6	195.7	192.9	197.9	194.0	145.5	232.6	229.3	241.4	238.1	264.6	260.1	304.2	269.0	72.2
78.7	-	-	-	-	126.8	169.8	166.4	195.1	192.9	197.3	194.0	129.0	231.5	229.3	240.3	238.1	264.6	260.1	304.2	260.1	78.7
85.3	-	-	-	-	114.9	169.2	165.3	195.1	191.8	196.2	192.9	116.2	230.4	227.1	239.2	238.1	264.6	260.1	304.2	253.5	85.3
91.9	-	-	-	-	103.0	168.7	165.3	195.1	191.8	195.1	192.9	103.4	229.3	227.1	238.1	235.9	264.6	253.5	304.2	246.9	91.9
98.4	-	-	-	-	93.3	167.6	164.2	194.0	190.7	194.6	192.9	92.9	229.3	227.1	237.0	235.9	263.5	246.9	302.0	241.4	98.4
111.5	-	-	-	-	75.6	165.3	162.0	192.4	189.2	192.9	190.7	74.0	228.2	224.1	234.8	231.5	261.2	235.2	297.6	229.3	111.5
124.7	-	-	-	-	61.3	162.8	159.8	191.1	187.8	190.7	188.5	58.6	225.6	220.5	232.2	224.9	257.9	224.9	286.6	218.3	124.7
137.8	-	-	-	-	48.5	160.9	157.6	189.6	186.3	188.5	186.3	45.0	222.7	216.1	229.3	216.1	253.5	216.1	271.2	209.4	137.8
150.9	-	-	-	-	38.5	158.0	154.7	186.7	183.4	185.6	181.1	34.2	218.3	208.0	224.9	208.0	244.0	208.0	257.9	200.6	150.9
164.0	-	-	-	-	29.5	155.1	152.1	184.1	180.8	182.6	174.9	24.5	213.8	199.9	220.8	199.9	235.2	199.9	244.7	193.3	164.0
177.2	-	-	-	-	21.4	152.1	149.9	181.9	178.6	179.7	167.6	15.9	209.4	191.8	217.2	191.8	229.3	191.8	232.8	185.9	177.2
190.3	-	-	-	-	14.8	149.5	147.3	176.4	174.5	175.9	162.0	8.6	206.1	185.6	213.8	185.6	221.8	185.4	222.7	178.6	190.3
203.4	-	-	-	-	7.9	145.1	142.9	171.6	170.5	171.2	156.2	-	201.0	178.9	209.4	178.9	213.8	178.9	214.6	172.7	203.4
216.5	-	-	-	-	-	142.2	140.0	168.7	167.6	167.6	151.0	-	197.3	173.1	205.0	173.1	207.2	173.1	202.1	167.2	216.5
229.7	-	-	-	-	-	138.2	135.6	163.5	161.7	162.4	145.9	-	189.2	167.9	191.8	167.9	193.3	167.9	185.2	162.0	229.7
242.8	-	-	-	-	-	134.5	132.3	160.2	155.8	158.0	141.5	-	178.6	163.1	178.6	163.1	179.3	163.1	170.5	156.9	242.8
255.9	-	-	-	-	-	130.1	130.1	156.5	152.1	152.1	137.8	-	165.3	158.7	165.3	158.7	165.3	158.7	155.8	152.1	255.9
269.0	-	-	-	-	-	127.9	125.7	144.8	143.3	141.5	133.4	-	152.9	151.4	152.9	151.4	152.1	153.2	142.2	143.3	269.0
282.2	-	-	-	-	-	124.0	123.5	132.9	134.0	131.2	128.2	-	141.1	141.5	140.7	141.8	140.7	140.7	129.9	130.8	282.2
295.3	-	-	-	-	-	121.3	119.0	122.4	123.5	120.2	120.2	-	130.1	130.1	129.0	130.1	129.0	129.0	118.3	119.4	295.3
308.4	-	-	-	-	-	116.1	113.9	113.5	114.3	110.2	110.8	-	119.0	119.8	118.7	119.0	117.6	117.9	108.0	109.1	308.4
321.5	-	-	-	-	-	109.4	106.9	104.9	105.6	102.4	101.7	-	109.1	110.1	109.0	109.1	107.9	108.7	98.5	99.7	321.5
334.6	-	-	-	-	-	101.2	98.1	96.8	97.4	94.4	93.5	-	100.3	100.5	99.9	100.1	98.8	99.0	89.9	90.8	334.6
347.8	-	-	-	-	-	94.0	89.1	89.6	90.1	86.9	85.9	-	91.5	92.1	91.1	91.3	90.0	90.2	81.6	82.2	347.8
360.9	-	-	-	-	-	86.0	80.1	82.8	83.3	80.3	78.8	-	83.7	84.2	83.1	83.6	81.9	82.2	74.1	74.6	360.9
374.0	-	-	-	-	-	77.2	71.0	76.5	76.9	73.9	71.9	-	76.1	76.7	75.6	76.1	74.3	74.7	66.9	67.2	374.0
387.1	-	-	-	-	-	67.5	62.5	70.9	71.2	67.7	65.6	-	69.4	70.3	68.7	69.6	67.5	67.9	60.0	60.2	387.1
400.3	-	-	-	-	-	57.9	53.8	65.6	65.8	61.7	59.7	-	63.3	64.2	62.6	63.6	61.3	62.3	53.6	53.9	400.3
413.4	-	-	-	-	-	48.9	45.2	60.6	60.8	56.2	54.2	-	57.5	58.6	56.9	58.2	55.6	56.9	47.7	48.0	413.4
426.5	-	-	-	-	-	39.2	35.9	56.1	56.3	51.2	49.3	-	52.7	54.2	52.2	53.6	50.9	52.5	42.1	42.5	426.5
429.8	-	-	-	-	-	36.8	-	54.9	55.2	50.0	48.1	-	51.5	53.1	51.0	52.5	49.7	51.4	40.9	41.2	429.8
433.1	-	-	-	-	-	35.1	-	53.8	54.0	48.7	-	-	50.3	-	49.8	-	48.5	-	39.6	-	433.1
439.6	-	-	-	-	-	30.2	-	51.7	-	46.4	-	-	48.2	-	47.8	-	46.4	-	37.2	-	439.6
442.9	-	-	-	-	-	28.2	-	50.7	-	45.2	-	-	47.2	-	46.7	-	45.4	-	35.9	-	442.9

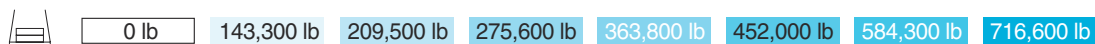

LSL+LF_2 – LSL+LF_6:  36.1 ft – 62.3 ft

LSL+LF_8 – LSL+LF_12:  36.1 ft – 68.9 ft

LSL+LF_14:  42.7 ft – 68.9 ft

LSL+LF_14:  496,100 lb +  110,200 lb

Operation

LSL+LF

363,800 lb + 110,200 lb 36.1-68.9 ft 27.6 ft 32.2 ft/s 360° ASME B30.5																					
472.4 ft																					
LSL+LF_2 LSL+LF_3 LSL+LF_4 LSL+LF_6 LSL+LF_8 LSL+LF_10 LSL+LF_12 LSL+LF_14																					
39.4 ft																					
0 lb 0-716.6 klb 0 lb 0-716.6 klb 0 lb 0-716.6 klb																					
15° 20° 30° 15° 20° 15° 20° 15° 20° 15° 20° 15° 20° 15° 20°																					
1,000 lb																					
ft	ft	ft	ft	ft	ft	ft	ft	ft	ft	ft	ft	ft	ft	ft	ft	ft	ft	ft	ft		
62.3	138.9	143.3	140.0	-	-	-	162.0	187.4	-	-	168.7	220.5	-	231.5	-	251.3	-	291.0	-	62.3	
65.6	138.9	143.3	140.0	-	154.3	165.3	162.0	187.4	184.1	194.0	189.6	158.7	220.5	218.3	231.5	227.1	251.3	246.9	291.0	277.8	65.6
68.9	137.8	142.7	139.4	131.2	146.6	164.8	161.5	187.1	184.1	194.0	189.6	150.5	220.5	217.7	230.9	227.1	251.3	246.9	291.0	273.4	68.9
72.2	137.8	142.2	138.9	131.2	138.9	164.2	160.9	186.8	184.1	194.0	189.6	142.2	220.5	217.2	230.4	227.1	251.3	246.9	291.0	269.0	72.2
78.7	127.9	141.1	137.8	130.1	123.5	163.1	159.8	186.3	183.0	194.0	189.6	125.7	220.5	217.2	229.3	227.1	251.3	246.9	291.0	262.4	78.7
85.3	114.6	140.0	136.7	130.1	111.8	162.6	158.7	186.3	183.0	193.5	188.5	113.0	219.9	217.2	228.2	224.9	251.3	246.9	291.0	255.7	85.3
91.9	103.6	138.9	135.6	129.0	100.1	162.0	157.6	186.3	181.9	192.9	188.5	100.3	219.4	216.1	227.1	224.9	251.3	246.9	291.0	249.1	91.9
98.4	93.3	137.8	134.5	127.9	90.5	160.4	156.5	185.2	181.9	192.4	187.4	90.1	218.8	216.1	227.1	224.9	250.2	246.9	289.9	242.5	98.4
111.5	76.5	134.8	132.3	125.7	73.1	157.6	154.3	183.0	179.7	190.7	185.9	71.3	217.2	215.3	226.0	223.4	248.0	236.6	286.6	230.4	111.5
124.7	61.8	132.3	129.7	123.8	58.9	155.4	152.1	181.1	177.8	188.5	184.5	56.1	215.0	213.5	223.4	220.8	245.4	226.7	283.3	220.5	124.7
137.8	49.2	130.1	126.8	122.4	46.3	153.2	149.9	179.7	176.4	186.3	183.0	42.5	212.7	210.5	220.5	217.2	242.5	217.2	273.4	211.3	137.8
150.9	39.2	127.1	124.6	119.4	36.3	149.5	146.2	176.7	173.4	184.1	180.0	32.0	209.1	206.1	216.8	209.1	232.2	209.1	260.1	201.7	150.9
164.0	30.1	124.2	122.0	116.8	27.3	146.2	142.9	173.8	170.5	180.8	175.3	22.3	205.0	200.6	212.4	201.4	225.8	201.4	248.4	194.4	164.0
177.2	22.0	121.3	119.0	114.6	19.2	143.3	140.0	170.9	167.6	176.4	168.7	13.7	200.6	194.0	207.2	194.0	219.4	194.0	237.0	187.2	177.2
187.0	17.0	119.3	116.8	113.0	14.3	141.1	137.5	167.3	163.4	173.9	164.8	8.2	197.6	189.0	204.2	189.0	215.0	189.0	228.2	181.9	187.0
190.3	15.3	118.6	116.1	112.4	12.7	140.0	136.7	166.7	162.6	173.3	163.1	-	196.8	187.4	203.4	187.4	213.5	187.4	224.9	180.8	190.3
200.1	10.3	116.1	114.1	110.2	7.9	137.1	134.8	163.5	158.9	171.2	158.5	-	194.2	182.6	200.8	182.6	207.1	182.6	215.5	175.8	200.1
203.4	8.6	115.4	113.5	109.8	-	136.3	134.1	162.8	156.9	170.5	157.3	-	193.3	181.1	199.9	181.1	204.3	181.1	212.4	174.2	203.4
216.5	-	112.4	111.3	108.0	-	133.4	131.2	159.8	152.1	167.6	152.1	-	189.6	175.3	196.2	175.3	198.4	175.3	198.0	168.3	216.5
229.7	-	110.1	108.4	105.5	-	128.6	126.0	154.7	147.0	162.4	147.0	-	183.7	170.1	185.9	170.1	188.1	170.1	181.9	163.1	229.7
242.8	-	106.2	105.3	103.0	-	124.2	122.0	149.2	142.9	157.6	142.6	-	174.2	165.0	174.2	165.0	176.0	165.0	167.2	158.7	242.8
255.9	-	103.0	101.4	100.5	-	121.3	119.0	145.5	140.0	151.0	138.9	-	160.9	159.8	160.9	159.8	162.0	159.8	152.5	152.9	255.9
269.0	-	100.3	98.9	96.7	-	117.2	115.7	141.1	134.8	139.6	134.5	-	149.5	148.8	150.1	149.2	151.0	149.2	140.0	141.1	269.0
282.2	-	96.5	95.2	93.3	-	114.3	112.4	131.5	129.3	129.0	127.5	-	137.8	138.9	137.8	138.5	137.8	138.5	126.8	129.3	282.2
295.3	-	94.1	93.0	91.3	-	111.3	110.0	121.3	121.3	117.9	117.9	-	126.8	127.9	126.8	126.8	126.8	126.8	116.0	117.5	295.3
308.4	-	91.1	90.1	89.5	-	108.5	105.5	111.7	112.3	109.1	107.9	-	116.2	117.3	115.7	116.8	115.7	116.5	105.6	106.9	308.4
321.5	-	89.1	88.2	86.7	-	104.3	98.8	103.0	103.5	100.5	99.9	-	106.9	106.9	106.7	106.9	105.7	106.6	96.0	97.2	321.5
334.6	-	87.3	86.4	85.1	-	98.5	89.3	94.8	95.2	92.2	90.4	-	97.9	98.1	97.4	97.9	96.8	97.0	87.4	88.4	334.6
347.8	-	85.0	84.3	83.3	-	88.7	80.4	87.6	88.0	84.8	82.8	-	89.2	89.7	88.8	89.3	88.1	88.3	79.1	80.0	347.8
360.9	-	83.1	82.8	82.1	-	78.8	71.3	80.8	81.2	77.7	75.8	-	81.4	81.8	80.8	81.4	80.0	80.2	71.7	72.3	360.9
374.0	-	80.9	81.4	80.9	-	69.0	61.7	74.5	74.7	71.0	69.0	-	73.9	74.3	73.2	73.9	72.3	72.5	64.5	65.1	374.0
387.1	-	75.3	75.6	76.1	-	59.5	52.0	68.8	69.2	64.6	62.6	-	66.9	67.5	66.5	67.0	65.5	65.9	57.8	58.2	387.1
390.4	-	73.9	74.2	33.7	-	57.3	49.9	67.4	67.8	63.2	61.2	-	65.3	65.9	64.9	65.5	63.8	64.3	56.2	56.6	390.4
400.3	-	70.0	70.2	-	-	50.0	43.2	63.3	63.7	58.9	57.0	-	60.8	61.6	60.3	61.1	59.2	59.8	51.4	51.9	400.3
413.4	-	64.8	65.0	-	-	41.0	34.0	58.4	58.6	53.4	51.4	-	54.9	56.0	54.5	55.6	53.4	54.2	45.5	45.9	413.4
426.5	-	60.4	60.6	-	-	31.1	24.1	53.9	54.1	48.4	46.4	-	50.0	51.3	49.5	50.9	48.3	49.6	39.9	40.3	426.5
433.1	-	58.2	58.4	-	-	26.7	19.4	51.6	51.8	45.9	43.9	-	47.6	48.9	47.0	48.5	45.9	47.4	37.4	37.8	433.1
436.4	-	57.2	57.3	-	-	24.2	-	50.5	50.8	44.8	42.8	-	46.6	48.1	46.0	47.6	44.9	46.5	36.2	36.6	436.4
439.6	-	56.1	56.2	-	-	21.7	-	49.5	49.8	43.7	-	-	45.6	-	45.0	-	43.9	-	34.9	-	439.6
442.9	-	55.1	19.4	-	-	19.2	-	48.4	-	42.5	-	-	44.5	-	44.0	-	42.9	-	33.7	-	442.9
452.8	-	52.0	-	-	-	12.1	-	45.2	-	39.2	-	-	41.4	-	41.0	-	39.9	-	30.2	-	452.8

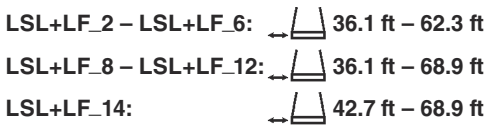

Operation

LSL+LF

363,800 lb + 110,200 lb 36.1-68.9 ft 27.6 ft 32.2 ft/s 360° ASME B30.5																	
482.3 ft																	
LSL+LF_3 LSL+LF_4 LSL+LF_6 LSL+LF_8 LSL+LF_10 LSL+LF_12 LSL+LF_14																	
39.4 ft																	
0 lb 0-716.6 klb 0 lb 0-716.6 klb																	
15° 20° 15° 20° 15° 20° 15° 20° 15° 20° 15° 20° 15° 20°																	
1,000 lb																	
ft																ft	
62.3	-	-	-	179.7	-	184.1	-	164.2	211.6	-	220.5	-	238.1	-	275.6	-	62.3
65.6	149.9	158.7	155.4	178.6	177.5	184.1	180.8	154.3	211.6	208.3	220.5	217.2	238.1	233.7	275.6	271.2	65.6
72.2	135.0	157.6	154.3	178.6	176.4	183.5	180.8	137.8	211.1	207.2	220.5	217.2	237.0	233.7	275.6	271.2	72.2
78.7	120.2	156.5	154.3	178.6	176.4	183.0	179.7	121.3	210.5	207.2	220.5	217.2	235.9	233.7	275.6	262.4	78.7
85.3	108.4	156.0	153.2	178.0	175.3	182.4	179.7	108.9	210.0	207.2	219.4	216.1	234.8	233.7	275.6	255.7	85.3
91.9	96.6	155.4	152.1	177.5	175.3	181.9	179.7	96.6	209.4	206.1	218.3	216.1	233.7	231.5	275.6	249.1	91.9
98.4	87.1	154.3	151.0	176.9	174.2	181.3	178.6	86.3	208.9	206.1	217.7	215.0	233.7	231.5	275.6	243.6	98.4
111.5	69.8	152.1	148.8	175.3	172.7	179.7	177.8	67.8	207.8	205.4	216.6	213.5	231.5	228.5	273.4	232.6	111.5
124.7	55.7	149.9	146.6	173.4	171.2	177.8	176.7	52.8	205.8	203.6	214.6	211.3	227.8	224.5	272.3	222.1	124.7
137.8	43.2	147.7	144.4	172.0	169.8	176.4	175.3	39.2	202.8	200.6	211.6	208.3	224.9	219.4	266.8	212.7	137.8
150.9	33.4	145.5	142.2	170.5	167.6	174.2	173.1	28.7	199.2	196.2	207.2	203.9	220.5	210.5	262.4	203.9	150.9
164.0	24.5	142.9	140.0	168.4	165.6	171.4	170.2	19.1	195.1	192.2	202.8	199.5	214.4	202.6	250.6	195.8	164.0
177.2	16.5	140.0	137.8	166.4	163.1	168.7	167.6	10.6	190.7	188.5	197.3	195.1	208.3	195.1	238.8	188.5	177.2
180.4	14.9	139.4	136.7	164.6	161.5	167.9	166.4	8.8	189.8	187.6	196.4	193.5	205.8	193.5	235.9	186.8	180.4
190.3	9.8	137.2	134.5	162.4	159.8	165.7	163.1	-	187.0	184.8	193.6	188.5	201.4	188.5	224.9	181.9	190.3
193.6	8.2	136.4	133.9	161.7	159.3	165.0	162.0	-	186.1	183.9	192.7	186.8	199.9	186.8	220.6	180.4	193.6
203.4	-	134.1	131.9	158.7	155.4	163.1	158.4	-	183.4	180.0	188.5	182.2	193.3	182.2	208.0	176.0	203.4
216.5	-	131.2	129.0	156.5	153.2	160.9	153.2	-	179.7	176.4	184.1	176.4	187.4	176.4	191.8	170.1	216.5
229.7	-	127.9	125.7	152.1	148.1	158.0	148.8	-	174.9	170.5	178.9	171.2	180.8	170.5	176.4	164.2	229.7
242.8	-	123.5	121.3	148.4	144.0	152.9	144.4	-	167.6	165.3	169.8	165.3	170.5	164.6	162.4	159.1	242.8
255.9	-	121.3	119.0	145.5	140.0	145.5	140.0	-	156.5	158.7	156.5	158.7	156.5	158.7	148.8	149.9	255.9
269.0	-	116.8	115.3	140.4	136.7	135.0	132.8	-	144.8	145.9	144.8	146.6	144.6	146.1	135.6	136.7	269.0
282.2	-	114.0	112.4	129.3	129.3	125.3	123.1	-	133.7	134.5	133.4	134.5	133.4	134.5	123.5	125.2	282.2
295.3	-	111.3	110.2	119.0	119.0	115.7	113.5	-	123.5	123.5	122.4	123.5	122.4	123.5	112.6	113.8	295.3
308.4	-	109.0	107.3	109.2	110.2	106.7	104.5	-	113.1	113.8	112.8	113.7	112.4	113.0	101.9	103.2	308.4
321.5	-	104.2	101.5	100.8	101.4	97.7	95.5	-	103.8	104.3	103.4	104.0	102.6	103.0	92.2	93.5	321.5
334.6	-	97.0	92.4	92.6	93.0	89.1	86.9	-	94.6	95.0	94.1	94.6	93.3	93.5	83.4	84.4	334.6
347.8	-	89.8	81.9	85.3	85.8	81.4	79.5	-	86.2	86.5	85.8	86.1	84.7	85.0	75.2	76.1	347.8
360.9	-	81.7	71.4	78.6	79.0	74.3	72.5	-	78.2	78.5	77.7	78.0	76.6	76.9	67.8	68.5	360.9
374.0	-	71.0	61.9	72.1	72.5	67.7	65.7	-	70.5	71.0	70.1	70.5	69.0	69.2	60.7	61.3	374.0
387.1	-	60.3	51.4	66.5	66.8	61.6	59.6	-	63.8	64.3	63.3	63.9	62.2	62.6	53.8	54.2	387.1
400.3	-	50.9	41.8	61.1	61.4	55.9	53.9	-	57.5	58.2	57.0	57.8	55.9	56.4	47.6	47.9	400.3
413.4	-	41.2	31.7	56.0	56.4	50.3	48.3	-	51.6	52.5	51.1	52.0	49.8	50.7	41.7	42.0	413.4
426.5	-	30.3	21.0	51.6	51.9	45.2	43.3	-	46.4	47.5	45.9	47.1	44.7	45.8	36.2	36.4	426.5
439.6	-	20.1	10.7	47.4	47.5	40.5	38.6	-	41.7	43.2	41.3	42.7	40.0	41.4	31.0	31.4	439.6
442.9	-	17.4	7.9	46.3	46.5	39.4	37.5	-	40.7	42.2	40.2	41.6	38.9	40.5	29.7	30.1	442.9
446.2	-	14.7	-	45.3	45.4	38.2	36.4	-	39.6	41.2	39.2	40.6	37.8	39.5	28.4	28.9	446.2
452.8	-	9.9	-	43.2	-	35.9	-	-	37.5	-	37.0	-	35.7	-	26.2	-	452.8
462.6	-	-	-	39.2	-	32.8	-	-	34.8	-	34.4	-	33.1	-	22.9	-	462.6

0 lb
 143,300 lb
 209,500 lb
 275,600 lb
 363,800 lb
 452,000 lb
 584,300 lb
 716,600 lb

LSL+LF_3 – LSL+LF_6: 36.1 ft – 62.3 ft

LSL+LF_8 – LSL+LF_12: 36.1 ft – 68.9 ft

LSL+LF_14: 42.7 ft – 68.9 ft

LSL+LF_14: 496,100 lb + 110,200 lb

Operation

LSL+LF

363,800 lb + 110,200 lb 36.1-68.9 ft 27.6 ft 32.2 ft/s 360° ASME B30.5															
492.1 ft															
LSL+LF_4 LSL+LF_6 LSL+LF_8 LSL+LF_10 LSL+LF_12 LSL+LF_14															
39.4 ft															
0 lb 0-716.6 klb 0 lb 0-716.6 klb															
15° 20° 15° 20° 15° 20° 15° 20° 15° 20° 15° 20°															
ft	1,000 lb													ft	
62.3	152.1	158.7	-	175.3	-	160.9	200.6	-	211.6	-	229.3	-	262.4	-	62.3
65.6	145.5	157.6	154.3	174.2	172.0	151.0	200.6	197.3	211.6	208.3	229.3	224.9	262.4	257.9	65.6
72.2	130.6	157.1	153.2	174.2	172.0	135.0	200.1	197.3	211.1	207.2	228.2	224.9	262.4	257.9	72.2
78.7	115.7	156.5	152.1	174.2	170.9	119.0	199.5	196.2	210.5	207.2	227.1	224.9	262.4	257.9	78.7
85.3	104.4	155.4	152.1	173.6	170.9	106.7	199.0	196.2	210.0	207.2	227.1	224.9	262.4	254.6	85.3
91.9	93.0	154.3	151.0	173.1	169.8	94.4	198.4	196.2	209.4	206.1	227.1	222.7	262.4	251.3	91.9
98.4	83.7	153.2	149.9	172.5	169.8	84.2	198.4	195.1	208.3	205.0	226.0	222.7	262.4	244.7	98.4
111.5	66.6	150.5	147.7	170.9	168.3	65.8	197.9	194.4	206.1	202.1	223.8	220.5	262.4	232.6	111.5
124.7	52.7	147.7	145.1	169.0	166.8	50.9	195.8	192.9	203.2	198.8	221.2	218.3	260.1	222.7	124.7
137.8	40.3	145.5	142.2	167.6	165.3	37.7	192.9	190.7	199.5	195.1	218.3	216.1	257.2	213.8	137.8
150.9	30.6	142.6	140.0	165.3	163.9	27.3	189.2	187.0	194.4	188.9	213.8	208.7	253.5	205.0	150.9
164.0	21.8	139.6	137.4	163.1	161.7	17.8	185.6	183.0	187.9	182.1	206.5	203.2	244.7	196.9	164.0
177.2	13.9	136.7	134.5	159.8	158.7	9.3	181.9	179.7	183.0	176.4	201.7	194.0	235.9	189.6	177.2
187.0	8.8	134.5	132.1	158.2	157.1	-	179.1	176.4	176.9	172.0	195.7	190.1	229.3	184.6	187.0
190.3	-	133.7	131.4	157.6	156.5	-	178.2	175.6	175.6	170.5	194.4	188.9	227.1	183.0	190.3
203.4	-	130.8	128.6	155.1	152.1	-	174.5	170.5	170.1	162.8	187.8	180.0	211.6	177.1	203.4
216.5	-	127.9	125.7	152.1	149.9	-	170.9	167.6	164.2	157.6	181.9	174.2	196.6	171.6	216.5
229.7	-	123.1	121.6	148.1	145.5	-	165.7	161.7	158.0	149.2	176.7	166.1	181.9	166.4	229.7
242.8	-	118.7	117.9	144.8	142.2	-	161.3	157.3	151.4	144.0	167.6	160.2	167.9	161.3	242.8
255.9	-	115.7	113.5	141.1	137.8	-	155.4	152.1	145.5	140.0	154.3	154.3	154.9	154.3	255.9
269.0	-	111.7	110.6	132.7	130.7	-	143.7	144.8	140.5	136.0	142.6	143.5	142.2	144.4	269.0
282.2	-	109.0	107.6	123.5	122.0	-	132.3	133.4	132.6	130.8	131.0	132.3	130.4	132.6	282.2
295.3	-	106.5	104.9	114.6	112.4	-	121.3	122.4	122.4	123.5	120.2	121.3	119.0	120.9	295.3
308.4	-	103.5	102.1	105.4	103.6	-	112.0	112.8	112.2	113.3	110.3	111.1	109.1	110.2	308.4
321.5	-	99.9	99.2	96.6	94.7	-	102.8	103.4	102.9	103.5	100.8	101.2	99.4	100.4	321.5
334.6	-	95.0	95.7	88.4	85.8	-	93.7	94.1	93.7	94.1	91.5	91.9	90.5	91.3	334.6
347.8	-	87.8	88.3	80.5	78.4	-	85.3	85.8	85.3	85.8	83.1	83.4	82.0	83.1	347.8
360.9	-	81.1	81.6	73.2	71.4	-	77.3	77.7	77.3	77.7	75.1	75.3	74.7	75.5	360.9
374.0	-	74.7	75.2	66.6	64.8	-	69.7	70.1	69.7	70.1	67.5	67.7	67.6	68.2	374.0
387.1	-	69.0	69.4	60.6	58.6	-	62.9	63.5	62.9	63.3	60.6	60.9	60.8	61.3	387.1
400.3	-	63.6	63.9	54.7	52.8	-	56.5	57.2	56.4	57.0	54.0	54.5	54.7	55.0	400.3
413.4	-	58.6	58.9	49.2	47.2	-	50.5	51.4	50.3	51.1	48.1	48.7	48.6	48.9	413.4
426.5	-	54.1	54.3	43.9	42.2	-	45.3	46.3	45.1	46.0	42.9	43.7	43.0	43.4	426.5
439.6	-	49.8	50.0	39.2	37.4	-	40.5	41.7	40.3	41.4	38.1	39.2	38.0	38.3	439.6
452.8	-	45.9	46.1	34.6	32.8	-	35.9	37.5	35.7	37.3	33.7	35.1	33.2	33.5	452.8
459.3	-	43.9	35.5	32.6	-	-	34.1	-	33.9	-	31.9	-	30.9	-	459.3
465.9	-	41.9	-	30.6	-	-	32.2	-	32.0	-	30.0	-	28.7	-	465.9
469.2	-	40.8	-	29.5	-	-	31.3	-	31.1	-	29.1	-	27.6	-	469.2

0 lb 143,300 lb 209,500 lb 275,600 lb 363,800 lb 452,000 lb 584,300 lb 716,600 lb

LSL+LF_4 – LSL+LF_6: 36.1 ft – 62.3 ft

LSL+LF_8 – LSL+LF_12: 36.1 ft – 68.9 ft

LSL+LF_14: 42.7 ft – 68.9 ft

LSL+LF_14: 496,100 lb + 110,200 lb

Operation

LSL+LF

363,800 lb + 110,200 lb 36.1-68.9 ft 27.6 ft 32.2 ft/s 360° ASME B30.5															
502.0 ft															
LSL+LF_4 LSL+LF_6 LSL+LF_8 LSL+LF_10 LSL+LF_12 LSL+LF_14															
39.4 ft															
0 lb 0-716.6 klb 0 lb 0-716.6 klb															
15° 20° 15° 20° 15° 20° 15° 20° 15° 20° 15° 20°															
ft	1,000 lb													ft	
62.3	147.7	152.1	-	166.4	-	155.4	191.8	-	201.7	-	217.2	-	249.1	-	62.3
65.6	142.2	152.1	148.8	166.4	163.1	146.6	190.7	-	200.6	-	217.2	-	249.1	-	65.6
68.9	134.8	151.8	148.3	166.2	163.1	138.6	190.4	188.5	200.6	197.3	216.9	213.8	249.1	244.7	68.9
72.2	127.3	151.6	147.7	165.9	163.1	130.6	190.1	187.4	200.6	197.3	216.6	213.8	249.1	244.7	72.2
78.7	112.4	151.0	147.7	165.3	162.0	114.6	189.6	187.4	200.6	197.3	216.1	213.8	249.1	244.7	78.7
85.3	101.1	149.9	146.6	164.8	162.0	102.6	189.6	187.4	200.1	197.3	216.1	213.8	249.1	244.7	85.3
91.9	89.7	148.8	145.5	164.2	160.9	90.6	189.6	186.3	199.5	196.2	216.1	213.8	249.1	244.7	91.9
98.4	80.5	147.7	144.4	163.7	160.9	80.6	189.0	186.3	198.4	195.1	215.0	212.7	249.1	242.5	98.4
111.5	63.6	145.5	142.2	162.0	160.2	62.4	187.9	185.6	196.8	192.9	214.4	212.0	249.1	234.8	111.5
124.7	49.9	143.3	140.4	160.2	159.1	47.6	186.3	183.7	194.4	190.0	212.7	210.2	246.9	224.3	124.7
137.8	37.7	141.1	138.9	158.7	157.6	34.4	184.1	180.8	190.7	186.3	210.5	207.2	245.4	215.0	137.8
150.9	28.0	138.9	136.0	157.3	156.2	24.1	180.4	177.8	186.3	181.9	206.1	202.1	242.5	206.1	150.9
164.0	19.3	136.5	133.6	155.1	154.0	14.6	177.1	174.2	180.8	177.5	199.3	196.2	235.2	198.8	164.0
173.9	13.4	134.5	132.3	152.9	152.5	8.2	174.2	171.6	177.5	172.0	195.3	192.9	229.3	193.2	173.9
177.2	11.5	133.4	131.2	152.1	152.1	-	173.1	170.9	176.4	170.9	194.0	191.8	227.1	191.3	177.2
183.7	7.9	132.3	130.1	151.0	151.0	-	171.2	169.0	172.0	167.9	191.8	188.1	222.7	187.4	183.7
190.3	-	131.2	129.0	149.9	149.9	-	169.4	167.2	169.8	165.0	189.6	184.5	218.3	184.1	190.3
203.4	-	128.6	126.4	147.7	147.7	-	165.7	162.8	164.6	158.4	184.1	179.3	204.3	178.2	203.4
216.5	-	125.7	123.5	145.5	145.5	-	162.0	158.7	158.7	153.2	179.7	174.2	190.3	172.7	216.5
229.7	-	122.4	120.2	143.3	141.1	-	157.3	155.8	154.3	145.9	172.3	167.6	176.4	167.6	229.7
242.8	-	118.5	117.9	140.9	138.2	-	153.2	149.5	147.3	140.5	162.0	160.9	163.1	161.7	242.8
255.9	-	115.7	113.5	137.8	134.5	-	148.8	144.4	142.2	135.6	148.8	151.0	150.1	152.1	255.9
269.0	-	111.6	110.2	128.2	126.4	-	138.5	138.0	137.1	131.8	137.8	139.3	137.8	140.0	269.0
282.2	-	109.3	108.0	119.0	117.9	-	128.1	129.3	129.2	127.3	126.4	127.9	125.7	128.2	282.2
295.3	-	106.3	105.6	110.2	108.9	-	117.9	119.0	117.9	119.0	115.7	116.8	115.2	117.1	295.3
308.4	-	104.0	102.5	101.7	100.1	-	108.4	109.3	108.5	109.3	106.2	107.0	105.2	106.5	308.4
321.5	-	99.6	98.9	93.3	91.3	-	99.2	99.8	99.3	99.8	96.9	97.4	95.6	96.6	321.5
334.6	-	93.0	93.5	84.9	82.5	-	90.2	90.8	90.4	90.8	87.7	88.2	86.5	87.5	334.6
347.8	-	85.5	86.2	76.9	75.1	-	81.9	82.5	82.0	82.3	79.4	79.8	77.8	78.9	347.8
360.9	-	78.9	79.4	69.6	68.0	-	74.0	74.4	73.9	74.2	71.3	71.7	70.5	71.4	360.9
374.0	-	72.5	73.0	63.3	61.5	-	66.6	67.0	66.4	66.8	63.9	64.2	63.6	64.4	374.0
387.1	-	66.8	67.2	57.2	55.3	-	59.8	60.3	59.6	60.0	57.0	57.4	56.9	57.5	387.1
400.3	-	61.4	61.8	51.4	49.5	-	53.4	53.8	53.0	53.6	50.5	51.0	50.7	51.1	400.3
413.4	-	56.4	56.7	45.9	43.9	-	47.4	48.1	47.0	47.6	44.5	45.0	44.8	45.3	413.4
426.5	-	51.9	52.1	40.9	38.9	-	42.0	42.9	41.7	42.5	39.2	40.0	39.2	39.7	426.5
439.6	-	47.6	47.8	36.1	34.2	-	37.0	38.1	36.7	37.7	34.3	35.3	34.1	34.5	439.6
452.8	-	43.4	43.7	31.5	29.8	-	32.4	33.7	32.2	33.3	29.8	31.1	29.2	29.7	452.8
462.6	-	40.7	40.8	28.4	26.7	-	29.5	30.9	29.2	30.6	26.7	28.2	25.8	26.2	462.6
465.9	-	39.8	39.9	27.4	-	-	28.6	-	28.2	-	25.8	-	24.7	-	465.9
469.2	-	38.8	13.7	26.4	-	-	27.6	-	27.2	-	24.9	-	23.7	-	469.2
479.0	-	35.3	-	23.4	-	-	24.9	-	24.3	-	22.3	-	20.7	-	479.0

0 lb
 143,300 lb
 209,500 lb
 275,600 lb
 363,800 lb
 452,000 lb
 584,300 lb
 716,600 lb

LSL+LF_4 – LSL+LF_6: 36.1 ft – 62.3 ft

LSL+LF_8 – LSL+LF_12: 36.1 ft – 68.9 ft

LSL+LF_14: 42.7 ft – 68.9 ft

LSL+LF_14: 496,100 lb + 110,200 lb

Operation

LSL+LF

363,800 lb + 110,200 lb 36.1-68.9 ft 27.6 ft 32.2 ft/s 360° ASME B30.5															
511.8 ft															
LSL+LF_4		LSL+LF_6		LSL+LF_8		LSL+LF_10		LSL+LF_12		LSL+LF_14					
39.4 ft															
0 lb		0-716.6 klb				0 lb		0-716.6 klb							
15°		20°		15°		20°		15°		20°		15°		20°	
ft	1,000 lb														ft
65.6	137.8	145.5	-	156.5	-	143.3	180.8	-	189.6	-	206.1	-	235.9	-	65.6
68.9	130.7	145.2	142.2	156.3	154.3	135.3	180.5	177.5	189.3	187.4	205.9	202.8	235.9	233.7	68.9
72.2	123.7	145.0	142.2	156.0	154.3	127.3	180.2	177.5	189.0	186.3	205.6	202.8	235.9	233.7	72.2
78.7	109.6	144.4	141.1	155.4	154.3	111.3	179.7	177.5	188.5	186.3	205.0	202.8	235.9	233.7	78.7
85.3	98.2	143.3	140.0	154.9	153.2	99.5	179.1	176.4	188.5	186.3	205.0	202.8	235.9	233.7	85.3
91.9	86.9	142.2	140.0	154.3	153.2	87.7	178.6	176.4	188.5	185.2	205.0	202.8	235.9	233.7	91.9
98.4	77.6	141.1	138.9	153.8	152.1	77.8	178.0	176.4	187.9	185.2	204.5	201.7	235.9	232.6	98.4
111.5	60.8	139.4	136.7	152.7	151.4	59.7	177.5	175.6	186.8	183.7	203.9	201.7	234.8	230.4	111.5
124.7	47.3	137.8	134.8	151.4	150.3	45.0	176.4	174.2	184.8	181.5	202.5	200.3	233.7	224.9	124.7
137.8	35.1	135.6	133.4	149.9	148.8	32.0	174.2	172.0	181.9	178.6	199.5	197.3	232.2	216.1	137.8
150.9	25.5	133.4	131.2	148.4	147.3	21.7	171.2	169.0	178.2	174.9	195.8	192.9	229.3	207.2	150.9
164.0	16.8	130.8	129.0	146.2	145.5	12.2	168.7	165.3	174.2	170.9	190.3	187.4	222.7	199.9	164.0
170.6	12.9	129.7	127.9	145.3	144.4	7.9	166.4	163.7	172.0	168.7	187.8	185.2	220.5	196.2	170.6
177.2	9.0	129.0	126.8	144.4	143.3	-	164.2	162.0	169.8	166.4	185.2	183.0	217.2	192.5	177.2
190.3	-	126.0	124.6	141.5	141.1	-	161.3	159.1	166.1	161.7	180.8	177.8	209.4	185.2	190.3
203.4	-	123.5	122.0	138.9	138.9	-	158.4	155.8	161.3	157.6	175.6	172.3	197.7	179.3	203.4
216.5	-	121.3	119.0	136.7	136.7	-	155.4	152.1	157.6	153.2	172.0	168.7	184.8	173.8	216.5
229.7	-	117.9	116.1	134.5	134.5	-	150.3	149.2	152.5	147.7	166.8	162.0	170.9	168.7	229.7
242.8	-	114.3	112.9	132.3	132.3	-	147.2	144.4	148.3	143.3	158.4	156.5	158.5	159.1	242.8
255.9	-	112.4	110.2	130.1	129.0	-	143.3	138.9	144.4	136.7	145.5	147.7	146.2	147.9	255.9
269.0	-	109.3	107.2	122.7	121.6	-	134.5	133.7	134.8	132.3	134.5	136.0	134.5	135.6	269.0
282.2	-	107.1	104.9	114.6	113.5	-	124.9	125.7	124.9	126.8	123.2	125.2	123.1	125.0	282.2
295.3	-	104.1	102.7	106.9	105.4	-	114.6	115.7	114.6	115.7	113.5	114.6	112.8	114.1	295.3
308.4	-	101.8	99.8	98.5	96.9	-	105.4	106.3	105.5	106.3	103.6	104.5	102.5	104.1	308.4
321.5	-	97.4	96.3	90.3	88.4	-	96.3	97.2	96.3	97.1	94.5	95.1	93.3	94.4	321.5
334.6	-	90.8	91.5	82.2	80.0	-	87.5	88.2	87.5	88.0	85.5	86.0	84.4	85.2	334.6
347.8	-	83.6	84.2	74.3	72.2	-	79.4	80.0	79.3	79.7	77.3	77.6	75.8	76.5	347.8
360.9	-	76.9	77.5	67.0	65.2	-	71.6	72.0	71.3	71.8	69.4	69.7	68.4	69.2	360.9
374.0	-	70.5	71.0	60.4	58.6	-	64.2	64.6	63.9	64.4	61.7	62.2	61.5	62.3	374.0
387.1	-	64.6	65.2	54.4	52.6	-	57.4	57.8	57.2	57.6	54.9	55.3	54.9	55.6	387.1
400.3	-	59.4	59.8	48.6	46.7	-	51.0	51.5	50.7	51.0	48.5	48.9	48.7	49.2	400.3
413.4	-	54.2	54.7	43.2	41.2	-	45.0	45.6	44.5	45.2	42.3	43.0	42.8	43.4	413.4
426.5	-	49.7	50.1	38.2	36.2	-	39.5	40.3	39.2	39.9	36.9	37.7	37.3	37.7	426.5
439.6	-	45.4	45.6	33.4	31.5	-	34.5	35.4	34.2	35.1	31.9	32.8	32.3	32.6	439.6
452.8	-	41.2	41.7	28.9	26.9	-	29.8	30.9	29.5	30.6	27.3	28.4	27.3	27.6	452.8
465.9	-	34.3	38.0	24.5	22.9	-	25.7	27.2	25.5	26.7	23.4	24.7	22.7	23.1	465.9
469.2	-	32.6	37.1	23.5	21.8	-	24.8	26.2	24.5	25.8	22.4	23.8	21.7	22.0	469.2
475.7	-	29.2	35.3	21.6	-	-	22.9	-	22.6	-	20.6	-	19.6	-	475.7
479.0	-	27.4	-	20.6	-	-	22.0	-	21.6	-	19.7	-	18.6	-	479.0
485.6	-	24.3	-	18.7	-	-	20.3	-	19.6	-	18.1	-	16.5	-	485.6

0 lb
 143,300 lb
 209,500 lb
 275,600 lb
 363,800 lb
 452,000 lb
 584,300 lb
 716,600 lb

LSL+LF_4 – LSL+LF_6: 36.1 ft – 62.3 ft

LSL+LF_8 – LSL+LF_12: 36.1 ft – 68.9 ft

LSL+LF_14: 42.7 ft – 68.9 ft

LSL+LF_14: 496,100 lb + 110,200 lb

Operation

LSL+LF

363,800 lb + 110,200 lb 36.1-68.9 ft 27.6 ft 32.2 ft/s 360° ASME B30.5															
521.7 ft															
LSL+LF_4 LSL+LF_6 LSL+LF_8 LSL+LF_10 LSL+LF_12 LSL+LF_14															
39.4 ft															
0 lb 0-716.6 klb 0 lb 0-716.6 klb															
15° 20° 15° 20° 15° 20° 15° 20° 15° 20° 15° 20°															
ft 1,000 lb ft															
65.6	134.5	138.9	-	148.8	-	138.9	173.1	-	180.8	-	196.2	-	224.9	-	65.6
68.9	127.4	138.6	136.7	148.5	146.6	131.2	172.5	169.8	180.5	178.6	195.9	192.9	224.9	220.5	68.9
72.2	120.3	138.3	136.7	148.3	146.6	123.6	172.0	169.8	180.2	177.5	195.7	192.9	224.9	220.5	72.2
78.7	106.0	137.8	135.6	147.7	146.6	108.2	170.9	168.7	179.7	177.5	195.1	192.9	224.9	220.5	78.7
85.3	94.8	137.2	135.6	147.2	145.5	96.1	170.9	168.7	179.1	176.4	195.1	192.9	224.9	220.5	85.3
91.9	83.6	136.7	134.5	146.6	145.5	84.0	170.9	168.7	178.6	176.4	195.1	192.9	224.9	220.5	91.9
98.4	74.5	136.1	133.4	146.1	144.4	74.2	170.3	167.6	178.0	176.4	194.6	191.8	224.9	220.5	98.4
111.5	58.0	134.5	131.9	145.0	143.7	56.3	169.2	166.8	176.9	174.2	193.5	191.1	223.8	220.5	111.5
124.7	44.5	132.6	130.4	143.7	142.6	41.8	167.6	165.0	175.3	172.0	191.8	189.2	221.6	218.8	124.7
137.8	32.4	131.2	129.0	142.2	141.1	28.9	165.3	162.0	173.1	169.8	189.6	186.3	219.7	214.2	137.8
150.9	22.9	129.0	126.8	140.7	139.6	18.6	162.4	159.1	170.2	166.1	187.4	184.1	218.3	208.3	150.9
164.0	14.1	126.8	124.9	138.9	137.8	9.0	159.1	155.9	165.3	162.0	180.8	177.8	212.4	201.0	164.0
173.9	8.2	125.1	123.8	137.2	136.1	-	156.3	153.9	162.0	158.7	177.5	174.2	209.4	195.7	173.9
177.2	-	124.6	123.5	136.7	135.6	-	155.4	153.2	160.9	157.6	176.4	173.1	207.7	194.0	177.2
190.3	-	123.1	121.3	134.5	133.4	-	151.8	149.5	157.3	153.2	171.6	168.7	200.6	187.4	190.3
203.4	-	121.3	119.0	132.3	131.5	-	148.4	144.8	153.2	148.8	167.6	162.0	190.3	180.8	203.4
216.5	-	119.0	116.8	130.1	130.1	-	145.5	141.1	148.8	144.4	163.1	157.6	178.6	174.2	216.5
229.7	-	116.2	114.6	127.9	128.6	-	140.9	136.3	145.1	138.9	158.4	152.1	165.3	167.6	229.7
242.8	-	112.4	111.3	125.7	126.8	-	136.7	132.3	141.1	134.0	152.6	147.5	152.5	155.2	242.8
255.9	-	110.2	109.6	123.5	123.5	-	133.4	127.9	136.7	129.0	141.1	142.2	140.7	142.9	255.9
269.0	-	108.0	106.6	117.6	116.8	-	128.2	123.5	130.5	124.6	129.6	131.2	129.0	131.2	269.0
282.2	-	106.0	104.7	110.5	109.4	-	120.9	118.6	120.5	119.3	119.6	120.5	118.8	120.4	282.2
295.3	-	103.0	102.3	102.5	101.2	-	111.3	112.4	110.2	111.3	109.6	110.2	108.4	109.8	295.3
308.4	-	101.0	99.7	94.4	93.0	-	102.0	102.9	101.6	102.6	99.9	100.8	98.3	100.1	308.4
321.5	-	96.3	95.8	86.4	84.7	-	92.9	93.7	92.6	93.4	90.8	91.6	89.2	90.5	321.5
334.6	-	88.8	89.3	78.5	76.5	-	84.2	84.9	83.8	84.4	82.0	82.5	80.3	81.4	334.6
347.8	-	81.5	82.1	70.8	68.3	-	76.1	76.8	75.7	76.1	73.6	74.1	71.9	72.5	347.8
360.9	-	74.7	75.3	63.6	61.6	-	68.4	69.0	67.9	68.3	65.9	66.3	64.4	65.3	360.9
374.0	-	68.3	68.8	56.7	55.1	-	61.1	61.5	60.4	60.8	58.4	58.6	57.4	58.3	374.0
387.1	-	62.5	62.9	50.8	49.2	-	54.2	54.8	53.6	54.0	51.5	51.9	50.9	51.6	387.1
400.3	-	57.2	57.6	45.3	43.4	-	47.9	48.4	47.3	47.7	45.2	45.5	44.9	45.4	400.3
413.4	-	52.0	52.5	39.9	37.9	-	41.9	42.3	41.2	41.7	39.0	39.5	39.1	39.5	413.4
426.5	-	47.4	47.8	34.9	32.9	-	36.4	37.0	35.8	36.4	33.6	34.2	33.5	34.0	426.5
439.6	-	42.5	43.0	30.1	28.1	-	31.3	30.8	30.6	31.4	28.2	29.2	27.3	27.4	439.6
452.8	-	37.3	38.1	25.6	23.6	-	26.5	23.6	25.8	26.0	23.6	24.7	21.2	21.5	452.8
465.9	-	29.5	31.8	21.5	19.6	-	18.8	14.5	19.9	16.9	19.5	20.9	15.4	15.9	465.9
475.7	-	24.4	26.7	18.5	16.8	-	12.9	7.7	14.9	10.1	16.6	18.1	11.8	12.3	475.7
479.0	-	23.6	-	17.6	-	-	10.7	-	12.8	-	15.7	-	10.6	-	479.0
482.3	-	21.7	-	16.6	-	-	8.6	-	10.7	-	14.9	-	9.4	-	482.3
485.6	-	19.7	-	15.7	-	-	-	-	8.6	-	14.0	-	8.2	-	485.6
492.1	-	15.9	-	13.9	-	-	-	-	-	-	12.3	-	-	-	492.1
495.4	-	13.9	-	13.0	-	-	-	-	-	-	11.7	-	-	-	495.4

0 lb
 143,300 lb
 209,500 lb
 275,600 lb
 363,800 lb
 452,000 lb
 584,300 lb
 716,600 lb

LSL+LF_4 – LSL+LF_6: 36.1 ft – 62.3 ft





























LSL+LF_8 – LSL+LF_12: 36.1 ft – 68.9 ft

LSL+LF_14: 42.7 ft – 68.9 ft

LSL+LF_14: 496,100 lb + 110,200 lb

Operation





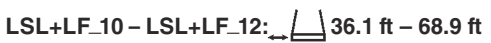



LSL+LF

 363,800 lb +  110,200 lb  36.1-68.9 ft  27.6 ft  32.2 ft/s 360° ASME B30.5															
 531.5 ft  541.3 ft															
 LSL+LF_10  LSL+LF_12  LSL+LF_14  LSL+LF_10  LSL+LF_12  LSL+LF_14															
 39.4 ft															
 0 lb  0-716.6 klb  0-716.6 klb															
 15°  20°  15°  20°  15°  20°  15°  20°  15°  20° 															
ft	1,000 lb														ft
65.6	134.5	170.9	-	185.2	-	215.0	-	130.1	162.0	-	176.4	-	203.9	-	65.6
68.9	127.1	170.6	168.7	184.9	181.9	215.0	211.6	122.7	161.8	-	176.1	-	203.9	-	68.9
72.2	119.7	170.3	168.7	184.6	181.9	215.0	211.6	115.4	161.5	159.8	175.8	174.2	203.9	201.7	72.2
78.7	104.9	169.8	167.6	184.1	181.9	215.0	211.6	100.8	160.9	159.8	175.3	173.1	203.9	201.7	78.7
85.3	92.9	169.2	167.6	183.5	180.8	215.0	211.6	89.0	160.4	158.7	175.3	173.1	203.9	201.7	85.3
91.9	80.9	168.7	167.6	183.0	180.8	215.0	211.6	77.2	159.8	158.7	175.3	173.1	203.9	201.7	91.9
98.4	71.2	168.7	166.4	182.4	180.8	215.0	211.6	67.6	159.8	157.6	174.2	172.0	203.9	201.7	98.4
111.5	53.6	168.1	165.0	181.3	179.3	213.8	211.1	50.2	159.3	156.9	172.0	169.8	202.8	200.6	111.5
124.7	39.2	166.4	163.1	179.7	177.5	212.7	209.4	35.9	157.6	155.4	169.4	166.8	201.2	200.1	124.7
137.8	26.2	164.2	160.9	177.5	175.3	210.5	206.1	22.9	155.4	153.2	166.4	163.1	199.9	197.7	137.8
150.9	16.1	161.6	158.3	174.2	172.0	208.3	201.7	12.9	153.2	151.0	163.1	159.8	198.4	194.0	150.9
157.5	11.0	159.8	157.6	173.1	170.9	206.1	198.8	7.9	152.1	149.9	160.9	157.6	196.2	191.4	157.5
160.8	8.8	158.9	156.2	171.8	167.7	205.0	197.3	-	151.2	149.0	158.7	155.8	195.3	190.0	160.8
164.0	-	158.0	155.1	170.5	166.8	203.9	195.8	-	150.3	148.1	157.6	154.3	194.7	188.7	164.0
177.2	-	154.3	152.1	165.3	163.1	199.5	190.3	-	146.6	144.4	153.2	149.9	190.3	183.4	177.2
190.3	-	150.6	148.4	160.9	157.3	192.9	184.1	-	143.7	141.5	147.0	144.8	185.2	177.5	190.3
203.4	-	147.0	144.0	156.5	152.9	184.8	177.5	-	140.7	138.5	141.8	138.5	177.8	171.6	203.4
216.5	-	143.3	141.1	152.1	147.7	174.5	170.5	-	137.8	135.6	136.7	133.4	168.0	165.0	216.5
229.7	-	139.8	136.3	147.7	142.9	162.0	163.1	-	133.7	132.3	129.5	128.3	155.4	157.6	229.7
242.8	-	134.9	131.9	143.5	136.7	149.5	151.7	-	129.7	127.5	124.6	122.0	143.7	145.9	242.8
255.9	-	132.3	127.9	140.0	132.3	137.8	140.0	-	126.8	124.6	119.0	116.8	132.3	134.5	255.9
269.0	-	127.0	122.6	129.0	127.1	126.8	129.0	-	122.7	120.2	112.0	110.4	121.3	123.5	269.0
282.2	-	119.6	116.8	118.8	119.8	116.5	117.7	-	114.5	114.2	105.8	106.1	111.6	113.6	282.2
295.3	-	109.6	110.2	109.3	110.2	106.3	107.8	-	105.4	106.7	98.8	101.4	101.9	103.8	295.3
308.4	-	100.3	101.2	99.9	101.1	96.6	98.1	-	96.3	97.4	91.7	95.7	92.2	94.1	308.4
321.5	-	91.3	92.4	90.9	91.9	87.5	88.8	-	87.5	88.5	84.6	88.4	83.2	84.9	321.5
334.6	-	82.7	83.6	82.2	82.9	78.6	79.7	-	78.9	79.8	77.4	79.6	74.7	75.9	334.6
347.8	-	74.7	75.2	74.1	74.5	70.3	71.0	-	71.0	71.7	70.3	71.5	66.4	67.2	347.8
360.9	-	67.1	67.5	66.4	66.8	62.5	63.5	-	63.4	64.0	63.0	63.7	58.7	59.6	360.9
374.0	-	59.7	60.2	59.1	59.3	55.4	56.4	-	56.2	56.7	55.3	56.2	51.6	52.4	374.0
387.1	-	52.8	53.1	52.2	52.5	48.9	49.8	-	49.4	49.9	44.9	48.0	45.0	46.1	387.1
400.3	-	46.5	47.0	45.9	46.2	43.1	43.8	-	43.1	43.5	35.1	38.3	37.5	39.2	400.3
413.4	-	40.3	40.8	39.7	40.1	36.7	37.3	-	37.0	37.5	26.0	27.6	30.0	31.6	413.4
426.5	-	34.9	35.3	34.1	34.7	30.0	30.4	-	31.5	32.0	17.9	18.4	22.5	23.4	426.5
439.6	-	29.5	30.2	28.8	29.5	23.1	23.1	-	26.2	26.8	10.4	10.1	15.9	16.3	439.6
442.9	-	28.2	29.0	27.6	28.2	21.5	21.5	-	25.0	25.6	8.6	8.2	14.2	14.6	442.9
452.8	-	24.7	25.6	24.0	24.9	16.9	17.0	-	21.4	22.0	-	-	9.6	9.7	452.8
456.0	-	23.7	24.1	22.7	23.7	15.4	15.5	-	20.3	20.2	-	-	8.2	8.2	456.0
465.9	-	20.6	19.8	18.9	20.1	11.0	11.2	-	17.0	14.7	-	-	-	-	465.9
472.4	-	18.5	17.0	16.3	17.6	8.4	8.8	-	14.8	11.0	-	-	-	-	472.4
475.7	-	16.9	14.9	15.0	16.1	-	-	-	12.9	8.8	-	-	-	-	475.7
479.0	-	15.2	12.8	13.6	14.6	-	-	-	11.1	-	-	-	-	-	479.0
482.3	-	13.6	10.7	12.2	13.0	-	-	-	9.3	-	-	-	-	-	482.3
485.6	-	11.9	8.6	10.9	11.5	-	-	-	-	-	-	-	-	-	485.6
492.1	-	8.6	-	8.2	-	-	-	-	-	-	-	-	-	-	492.1



Operation

LSL+LF

 496,100 lb +  110,200 lb  42.7-68.9 ft  27.6 ft  32.2 ft/s 360° ASME B30.5															
 295.3 ft 305.1 ft 315.0 ft 324.8 ft 334.6 ft 344.5 ft															
LSL+LF_14															
59.0 ft															
 0 lb 0-716.6 klb 0 lb 0-716.6 klb 0 lb 0-716.6 klb 															
15° 20° 15° 20° 15° 20° 15° 20° 15° 20° 15° 20° 															
ft	1,000 lb														ft
52.5	262.4	264.6	-	264.6	-	266.8	266.8	-	-	-	-	-	-	-	52.5
55.8	255.7	256.8	-	257.9	-	260.1	260.1	-	262.4	-	262.4	264.6	-	264.6	55.8
59.1	249.1	249.1	183.0	251.3	184.1	253.5	253.5	185.2	255.7	-	255.7	257.9	-	257.9	59.1
62.3	242.5	242.5	179.1	244.7	180.2	246.9	246.9	181.3	249.1	181.9	250.2	251.3	183.0	252.4	62.3
65.6	235.9	235.9	175.3	238.1	176.4	240.3	240.3	177.5	242.5	178.6	244.7	244.7	179.7	246.9	65.6
72.2	224.9	224.9	168.7	227.1	169.8	229.3	229.3	170.9	231.5	172.0	224.9	233.7	173.1	235.9	72.2
78.7	215.0	215.0	162.0	217.2	163.1	212.7	219.4	164.2	220.5	165.3	203.9	222.7	166.4	224.9	78.7
85.3	199.5	205.6	156.5	208.3	157.6	195.1	210.5	158.7	212.2	159.8	186.3	214.4	160.9	216.1	85.3
91.9	184.1	196.2	151.0	199.5	152.1	177.5	201.7	153.2	203.9	154.3	168.7	206.1	155.4	207.2	91.9
98.4	169.8	188.5	146.1	191.8	147.2	163.1	194.0	148.3	196.2	149.4	154.9	198.4	151.0	200.1	98.4
111.5	143.9	174.2	136.7	177.5	137.8	137.2	179.7	139.4	181.9	140.5	130.1	184.1	142.2	186.3	111.5
124.7	122.9	162.0	128.4	164.8	130.1	116.8	167.0	131.7	169.2	132.8	110.3	171.4	133.9	173.6	124.7
137.8	106.0	151.8	121.6	154.0	123.5	100.5	156.2	124.6	158.4	125.7	94.2	160.6	126.8	162.8	137.8
150.9	91.1	142.2	115.7	144.4	116.8	85.5	146.6	117.9	148.8	119.0	79.4	151.0	120.2	153.2	150.9
164.0	77.1	134.1	110.3	136.3	111.6	72.8	138.5	112.8	140.7	113.9	67.8	142.9	115.0	145.1	164.0
177.2	64.7	126.8	105.2	129.0	106.6	60.9	131.2	107.9	133.4	109.1	56.6	135.6	110.2	137.4	177.2
190.3	53.8	120.2	100.5	122.4	101.9	50.0	124.6	103.2	126.8	104.5	45.9	129.0	105.6	130.1	190.3
203.4	45.1	115.0	96.7	117.2	98.0	41.2	118.7	99.2	120.9	100.5	36.7	123.1	101.6	124.2	203.4
216.5	37.3	110.2	93.2	112.3	94.4	33.3	113.6	95.5	115.4	96.8	28.8	117.6	97.9	118.7	216.5
229.7	30.2	105.8	89.9	107.6	91.1	26.2	109.3	92.2	110.2	93.3	22.0	112.4	94.4	113.5	229.7
242.8	24.3	101.9	87.2	103.5	88.3	20.2	105.2	89.2	106.6	90.3	15.6	108.3	91.4	109.7	242.8
255.9	18.7	98.2	84.6	99.7	85.6	14.4	101.3	86.6	102.8	87.6	9.4	104.4	88.6	106.0	255.9
259.2	17.3	97.3	84.0	98.9	85.0	13.0	100.4	86.0	101.9	87.0	7.9	103.4	88.0	105.1	259.2
269.0	13.2	94.8	82.2	96.3	83.1	8.8	97.7	84.2	99.2	85.1	-	100.8	86.2	102.3	269.0
282.2	8.4	91.9	80.3	93.4	81.1	-	94.7	82.1	96.1	83.0	-	97.7	84.0	99.1	282.2
295.3	-	89.4	78.7	90.8	79.5	-	92.0	80.3	93.3	81.1	-	94.7	82.0	96.0	295.3
308.4	-	87.1	77.4	88.4	78.0	-	89.5	78.7	90.6	79.4	-	91.9	80.2	93.3	308.4
315.0	-	86.2	-	87.5	77.4	-	88.5	78.1	89.6	78.7	-	90.8	79.5	92.1	315.0
318.2	-	85.8	-	87.0	-	-	88.0	77.8	89.1	78.4	-	90.3	79.1	91.5	318.2
321.5	-	-	-	86.5	-	-	87.5	77.5	88.6	78.0	-	89.7	78.8	90.9	321.5
324.8	-	-	-	86.0	-	-	86.9	77.2	88.0	77.7	-	89.2	78.4	90.3	324.8
328.1	-	-	-	85.5	-	-	86.4	-	87.5	77.4	-	88.6	78.0	89.7	328.1
334.6	-	-	-	-	-	-	85.8	-	86.6	76.9	-	87.7	77.5	88.8	334.6
341.2	-	-	-	-	-	-	-	-	85.8	-	-	86.9	76.9	87.8	341.2
344.5	-	-	-	-	-	-	-	-	85.3	-	-	86.4	-	87.3	344.5
347.8	-	-	-	-	-	-	-	-	-	-	-	86.0	-	86.9	347.8
351.1	-	-	-	-	-	-	-	-	-	-	-	85.5	-	86.5	351.1
360.9	-	-	-	-	-	-	-	-	-	-	-	-	-	85.3	360.9

	0 lb	143,300 lb	209,500 lb	275,600 lb	363,800 lb	452,000 lb	584,300 lb	716,600 lb
---	------	------------	------------	------------	------------	------------	------------	------------

Operation





LSL+LF

496,100 lb +		110,200 lb		42.7-68.9 ft				27.6 ft		32.2 ft/s		360°		ASME B30.5	
354.3 ft		364.2 ft		374.0 ft				383.9 ft		393.7 ft		403.5 ft		LSL+LF_14	
59.0 ft															
0 lb		0-716.6 klb				0 lb		0-716.6 klb				0 lb		0-716.6 klb	
15°		20°		15°		20°		15°		20°		15°		20°	
1,000 lb															
ft															ft
55.8	-	266.8	-	-	-	-	-	-	-	-	-	-	-	-	55.8
59.1	260.1	260.1	-	262.4	-	257.9	264.6	-	264.6	-	-	-	-	-	59.1
62.3	250.2	254.6	184.1	255.7	-	243.6	257.9	-	259.0	-	233.7	260.1	-	262.4	62.3
65.6	240.3	249.1	180.8	249.1	181.9	229.3	251.3	183.0	253.5	183.0	220.5	255.7	184.1	255.7	65.6
68.9	228.2	243.6	177.5	243.6	178.6	218.3	245.8	179.7	248.0	180.2	209.4	250.2	180.8	250.2	68.9
72.2	216.1	238.1	174.2	238.1	175.3	207.2	240.3	176.4	242.5	177.5	198.4	244.7	177.5	244.7	72.2
78.7	196.2	227.1	168.7	229.3	169.8	187.4	231.5	170.9	231.5	170.9	179.7	233.7	172.0	235.9	78.7
85.3	179.1	218.3	163.1	220.5	164.2	170.9	222.7	165.3	223.2	165.9	163.1	225.4	167.0	227.6	85.3
91.9	162.0	209.4	157.6	211.6	158.7	154.3	213.8	159.8	215.0	160.9	146.6	217.2	162.0	219.4	91.9
98.4	148.3	201.7	153.2	203.9	154.3	141.1	206.1	155.4	207.8	156.0	133.9	209.4	157.1	211.6	98.4
111.5	124.0	187.4	144.4	189.6	145.5	117.4	191.8	146.6	194.0	147.2	111.0	195.1	148.3	197.3	111.5
124.7	104.6	175.3	136.1	177.5	137.2	98.1	179.1	138.3	181.3	139.4	92.0	183.0	140.5	184.6	124.7
137.8	88.4	165.0	129.3	166.8	130.4	82.2	168.3	131.5	170.5	132.6	76.4	172.3	133.7	173.8	137.8
150.9	73.9	155.4	123.5	156.5	124.6	67.9	158.7	125.7	160.9	126.8	62.4	162.0	127.9	164.2	150.9
164.0	62.4	146.6	117.6	148.4	118.7	56.6	150.6	119.8	152.1	120.9	51.2	154.0	122.0	156.2	164.0
177.2	51.7	138.9	112.4	141.1	113.5	46.3	142.9	114.6	144.4	115.7	41.0	146.2	116.8	148.4	177.2
190.3	41.9	132.3	108.0	134.5	109.1	37.0	135.6	110.2	137.8	111.3	31.7	138.9	112.4	141.1	190.3
203.4	32.5	126.4	103.9	127.9	105.0	27.5	129.7	106.1	131.2	107.2	22.8	133.0	108.3	134.5	203.4
216.5	24.4	120.9	100.1	122.0	101.2	18.8	124.2	102.3	125.3	103.3	14.3	127.4	104.4	129.0	216.5
226.4	19.3	117.0	97.4	118.1	98.5	13.0	120.3	99.6	121.4	100.6	8.4	123.5	101.7	124.9	226.4
229.7	17.6	115.7	96.6	116.8	97.7	11.0	119.0	98.8	120.2	99.6	-	122.4	100.8	123.5	229.7
236.2	14.4	113.7	95.0	114.6	96.1	9.3	116.8	97.2	117.9	98.2	-	119.8	99.1	121.3	236.2
242.8	11.2	111.6	93.5	112.4	94.5	-	114.6	95.5	115.7	96.6	-	117.2	97.5	119.0	242.8
249.3	7.9	109.6	91.9	110.2	93.0	-	112.4	93.9	113.5	95.0	-	114.6	95.9	116.8	249.3
255.9	-	107.7	90.6	108.5	91.7	-	110.5	92.6	111.7	93.6	-	113.0	94.5	114.6	255.9
269.0	-	103.8	88.0	105.2	89.1	-	106.7	89.9	108.0	90.8	-	109.6	91.7	110.2	269.0
282.2	-	100.5	85.8	101.8	86.7	-	103.2	87.6	104.6	88.5	-	106.0	89.4	107.1	282.2
295.3	-	97.4	83.7	98.6	84.5	-	99.9	85.4	101.4	86.2	-	102.7	87.1	104.0	295.3
308.4	-	94.6	81.8	95.7	82.5	-	97.0	83.3	98.3	84.0	-	99.6	84.9	100.8	308.4
321.5	-	92.1	80.2	93.2	80.8	-	94.4	81.6	95.7	82.2	-	96.9	83.1	98.0	321.5
334.6	-	89.8	78.7	90.9	79.4	-	91.9	80.0	93.2	80.6	-	94.3	81.4	95.3	334.6
347.8	-	87.7	77.4	88.8	78.0	-	89.7	78.5	90.8	79.1	-	91.9	79.8	93.0	347.8
357.6	-	86.5	76.7	87.5	77.3	-	88.4	77.7	89.3	78.3	-	90.4	78.8	91.5	357.6
360.9	-	86.1	-	87.1	77.0	-	88.0	77.5	88.8	78.0	-	89.9	78.5	91.0	360.9
367.5	-	85.3	-	86.2	76.5	-	87.1	76.9	88.0	77.4	-	88.8	77.8	89.9	367.5
370.7	-	85.1	-	85.8	-	-	86.6	76.7	87.5	77.2	-	87.8	77.6	88.2	370.7
374.0	-	-	-	85.5	-	-	86.3	76.5	86.9	76.9	-	86.7	77.4	86.4	374.0
377.3	-	-	-	85.1	-	-	85.9	-	86.4	76.7	-	85.6	77.2	84.7	377.3
383.9	-	-	-	-	-	-	85.2	-	85.4	76.3	-	83.5	76.7	81.1	383.9
387.1	-	-	-	-	-	-	84.9	-	84.9	-	-	82.5	76.5	79.4	387.1
390.4	-	-	-	-	-	-	-	-	83.3	-	-	81.0	76.3	77.8	390.4
393.7	-	-	-	-	-	-	-	-	81.8	-	-	79.5	-	76.3	393.7
400.3	-	-	-	-	-	-	-	-	-	-	-	76.5	-	73.2	400.3
403.5	-	-	-	-	-	-	-	-	-	-	-	75.0	-	71.7	403.5
413.4	-	-	-	-	-	-	-	-	-	-	-	-	-	67.2	413.4

	0 lb	143,300 lb	209,500 lb	275,600 lb	363,800 lb	452,000 lb	584,300 lb	716,600 lb
--	------	------------	------------	------------	------------	------------	------------	------------

Operation

LSL+LF

496,100 lb +  110,200 lb		 42.7-68.9 ft		 27.6 ft		 32.2 ft/s		360°		ASME B30.5					
413.4 ft		423.2 ft		433.1 ft		442.9 ft		452.8 ft		462.6 ft		472.4 ft			
LSL+LF_14															
59.0 ft															
0 lb		0-716.6 klb		0 lb		0-716.6 klb		0 lb		0-716.6 klb		0 lb		0-716.6 klb	
15°		20°		15°		20°		15°		20°		15°		20°	
ft															
1,000 lb															
62.3	222.7	262.4	-	264.6	-	-	-	-	-	-	-	-	-	-	-
65.6	210.5	257.9	-	260.1	-	201.7	260.1	-	262.4	-	192.9	260.1	-	257.9	-
68.9	199.5	252.4	181.9	254.6	183.0	191.3	254.6	183.0	256.8	-	182.4	256.8	-	257.9	-
72.2	188.5	246.9	178.6	249.1	179.7	180.8	249.1	180.8	251.3	180.8	172.0	253.5	181.9	253.5	181.9
77.8	169.8	238.1	173.1	238.1	174.2	162.0	240.3	175.3	242.5	175.3	153.2	242.5	176.4	244.7	176.4
85.3	153.8	229.3	168.1	230.4	169.2	146.6	231.5	170.3	233.7	170.3	138.3	234.8	171.4	235.9	172.0
91.9	137.8	220.5	163.1	222.7	164.2	131.2	222.7	165.3	224.9	165.3	123.5	227.1	166.4	227.1	167.6
98.4	125.7	212.7	158.7	215.0	159.8	119.2	215.0	160.9	217.7	160.9	111.8	219.4	162.0	220.5	163.1
111.5	103.3	199.0	150.5	200.6	151.0	97.0	202.3	152.1	203.9	152.7	90.2	205.6	153.8	207.2	154.9
124.7	84.5	186.8	142.7	188.5	143.3	78.5	190.1	144.4	191.8	145.5	72.0	193.5	146.1	195.1	147.2
137.8	69.1	176.0	135.6	177.8	136.7	63.3	179.3	137.8	181.1	138.9	57.0	182.6	139.3	184.5	140.4
150.9	55.1	166.4	129.0	167.6	130.1	49.8	169.8	131.2	170.9	132.3	43.7	173.1	133.4	174.2	134.5
164.0	44.1	157.6	123.8	159.5	124.9	38.8	160.9	126.0	162.8	127.1	32.9	164.2	127.5	165.3	128.6
177.2	34.1	149.5	118.7	151.8	119.8	28.9	152.9	120.9	155.1	122.0	23.1	156.2	122.4	157.3	123.5
190.3	25.1	142.2	113.5	144.4	114.6	20.1	145.5	115.7	147.7	116.8	14.3	148.8	117.9	149.9	119.0
200.1	18.7	137.8	110.9	139.4	111.9	13.9	141.1	113.0	142.7	113.5	8.4	144.4	114.6	145.7	115.7
203.4	16.6	136.3	110.0	137.8	111.0	11.8	139.6	112.1	141.1	112.4	-	142.6	113.5	144.2	114.6
210.0	12.3	133.4	108.2	134.5	109.1	7.7	136.7	110.2	137.8	110.2	-	138.9	111.3	141.1	112.4
216.5	8.2	130.1	106.3	131.9	107.3	-	133.7	108.2	135.2	108.6	-	136.3	109.6	138.2	110.7
229.7	-	125.7	102.7	126.8	103.6	-	127.9	104.5	130.1	105.4	-	131.2	106.3	132.3	107.1
242.8	-	120.5	99.5	121.6	100.4	-	123.5	101.3	124.9	102.1	-	126.0	103.0	127.1	103.9
255.9	-	115.7	96.4	117.2	97.3	-	119.0	98.2	120.2	99.1	-	121.3	99.9	122.7	100.8
269.0	-	111.3	93.5	113.5	94.4	-	114.6	95.2	115.7	96.1	-	116.8	97.0	119.0	97.9
282.2	-	108.7	91.1	110.0	91.9	-	111.3	92.8	111.9	93.6	-	113.5	94.4	114.6	95.2
295.3	-	105.3	88.7	106.6	89.5	-	107.7	90.3	108.8	91.2	-	109.9	91.9	111.3	92.7
308.4	-	102.1	86.4	103.2	87.3	-	104.5	88.0	105.8	88.8	-	106.9	89.5	108.0	90.4
321.5	-	99.3	84.5	100.4	85.3	-	101.4	86.1	102.7	86.8	-	103.8	87.5	102.0	88.3
334.6	-	96.6	82.7	97.7	83.4	-	98.2	84.2	97.7	84.9	-	97.4	85.5	94.1	86.2
347.8	-	94.1	81.1	95.2	81.8	-	94.4	82.5	90.6	83.1	-	88.6	83.8	84.4	84.4
360.9	-	90.5	79.7	88.4	80.3	-	86.5	80.9	82.8	80.8	-	81.1	80.0	76.9	77.5
374.0	-	84.9	78.3	81.1	77.9	-	79.1	77.7	75.4	76.1	-	73.9	74.5	69.7	70.5
387.1	-	77.8	77.4	74.1	74.5	-	72.1	72.5	68.3	69.0	-	66.8	67.5	62.8	63.7
400.3	-	71.5	71.7	67.8	68.0	-	65.5	66.0	61.8	62.4	-	60.5	61.2	56.7	57.2
406.8	-	68.3	68.8	64.6	64.8	-	62.4	62.8	58.6	59.3	-	57.3	58.0	53.6	54.0
413.4	-	65.5	-	61.6	62.1	-	59.5	60.0	55.8	56.4	-	54.5	55.1	50.6	51.1
416.7	-	64.0	-	60.2	60.6	-	58.1	58.6	54.3	55.0	-	53.0	53.7	49.2	49.7
419.9	-	62.6	-	58.8	-	-	56.7	57.2	52.9	53.6	-	51.6	52.2	47.8	48.3
423.2	-	-	-	57.4	-	-	55.2	55.8	51.5	52.1	-	50.2	50.8	46.4	46.8
426.5	-	-	-	56.0	-	-	53.8	-	50.0	50.7	-	48.7	49.4	45.0	45.4
429.8	-	-	-	54.9	-	-	52.5	-	48.7	49.4	-	47.4	48.1	43.7	44.2
433.1	-	-	-	-	-	-	51.3	-	47.4	48.1	-	46.2	46.7	42.4	42.9
436.4	-	-	-	-	-	-	50.0	-	46.2	-	-	44.9	45.4	41.1	41.7
439.6	-	-	-	-	-	-	-	-	45.0	-	-	43.7	44.1	39.8	40.4
446.2	-	-	-	-	-	-	-	-	42.5	-	-	41.2	-	37.3	37.9
449.5	-	-	-	-	-	-	-	-	-	-	-	40.1	-	36.1	36.6
452.8	-	-	-	-	-	-	-	-	-	-	-	38.9	-	35.0	-
456.0	-	-	-	-	-	-	-	-	-	-	-	37.7	-	33.8	-
462.6	-	-	-	-	-	-	-	-	-	-	-	-	-	31.5	-
465.9	-	-	-	-	-	-	-	-	-	-	-	-	-	-	29.4
472.4	-	-	-	-	-	-	-	-	-	-	-	-	-	-	28.2
															26.0

	0 lb	143,300 lb	209,500 lb	275,600 lb	363,800 lb	452,000 lb	584,300 lb	716,600 lb
---	------	------------	------------	------------	------------	------------	------------	------------

Operation

LSL+LF

496,100 lb + 110,200 lb 42.7-68.9 ft 27.6 ft 32.2 ft/s 360° ASME B30.5																	
482.3 ft 492.1 ft 502.0 ft 511.8 ft 521.7 ft 531.5 ft 541.3 ft																	
LSL+LF 14																	
59.0 ft																	
0-716.6 klb 0 lb 0-716.6 klb 0 lb 0-716.6 klb 0 lb 0-716.6 klb																	
15° 20° 15° 20° 15° 20° 15° 20° 15° 20° 15° 20° 15° 20°																	
1,000 lb																	
ft																	ft
68.9	238.1	-	170.9	227.1	-	217.2	-	-	-	-	-	-	-	-	-	-	68.9
72.2	238.1	-	160.9	227.1	-	217.2	-	153.2	208.3	-	199.5	-	145.5	191.8	-	183.0	72.2
75.5	238.1	180.8	152.7	227.1	180.8	217.2	181.9	145.0	208.3	181.9	199.5	-	137.8	191.8	-	183.0	75.5
78.7	238.1	177.5	144.4	227.1	178.6	217.2	178.6	136.7	208.3	179.7	199.5	179.7	130.1	191.8	177.5	183.0	78.7
85.3	234.8	173.1	130.1	227.1	173.6	217.2	174.2	123.0	208.3	174.7	199.5	175.3	116.4	191.8	174.2	183.0	85.3
91.9	231.5	168.7	115.7	227.1	168.7	217.2	169.8	109.3	208.3	169.8	199.5	170.9	102.7	191.8	170.9	183.0	91.9
98.4	223.8	164.2	104.4	222.7	164.8	216.6	165.3	98.0	207.8	165.9	199.0	166.4	91.7	191.3	167.0	182.4	98.4
111.5	210.0	156.0	83.6	211.6	157.1	211.1	157.1	77.4	205.6	158.2	196.8	158.7	71.5	189.0	159.3	180.8	111.5
124.7	197.9	148.8	66.1	199.5	149.4	200.6	149.9	60.3	200.1	151.0	193.5	151.6	54.7	186.3	152.1	178.0	124.7
137.8	187.0	142.2	51.7	188.9	142.6	190.0	143.7	46.1	191.4	144.4	189.6	144.8	40.6	182.6	145.9	175.3	137.8
150.9	177.5	135.6	38.8	178.6	136.7	179.7	137.8	33.3	181.9	137.8	183.0	138.9	28.0	177.5	140.0	170.9	150.9
164.0	168.7	130.4	28.2	169.8	131.5	171.6	131.9	23.0	173.1	132.6	174.2	133.7	17.9	171.6	134.1	165.3	164.0
177.2	160.7	125.3	18.7	161.7	126.4	163.6	126.8	13.4	164.8	127.9	166.1	128.4	8.2	165.3	129.0	160.2	177.2
183.7	157.2	122.7	14.4	158.0	123.8	159.6	124.6	9.0	160.9	125.7	162.4	125.7	-	162.6	126.8	157.3	183.7
190.3	153.2	120.2	10.1	154.3	121.3	156.5	122.4	-	157.6	123.5	158.7	123.5	-	159.8	124.6	154.3	190.3
193.6	151.6	119.2	8.2	153.2	120.2	154.9	121.3	-	156.0	122.4	157.1	122.4	-	158.2	123.5	153.0	193.6
203.4	146.6	116.5	-	148.6	116.8	149.9	117.9	-	151.0	119.0	152.1	119.0	-	153.2	120.2	149.2	203.4
216.5	140.7	112.7	-	142.6	113.0	143.7	113.9	-	144.8	115.0	145.9	115.0	-	147.3	116.2	144.0	216.5
229.7	135.6	108.9	-	136.7	109.8	137.8	110.2	-	138.9	111.3	140.0	111.3	-	142.2	112.4	138.9	229.7
242.8	130.4	105.6	-	131.5	106.4	132.6	107.1	-	133.7	108.0	135.6	108.7	-	136.3	109.4	132.7	242.8
255.9	125.7	102.4	-	126.8	103.2	127.9	104.1	-	129.0	104.9	130.8	105.6	-	130.4	106.3	127.3	255.9
269.0	121.3	99.4	-	122.4	100.3	123.5	101.0	-	124.6	101.9	125.7	102.5	-	124.6	103.2	122.4	269.0
282.2	117.6	96.8	-	118.7	97.5	119.8	98.3	-	121.0	99.1	120.9	99.7	-	117.5	100.5	113.2	282.2
295.3	112.3	94.3	-	115.1	94.9	115.7	95.8	-	114.6	96.4	111.0	97.1	-	108.8	98.0	104.1	295.3
308.4	105.4	91.9	-	111.3	92.6	108.2	93.3	-	105.8	93.9	101.6	94.6	-	99.4	95.5	95.0	308.4
321.5	95.8	89.7	-	102.5	90.4	98.7	91.1	-	96.6	91.8	92.5	92.4	-	90.6	92.0	86.3	321.5
334.6	86.8	85.6	-	93.7	83.4	89.9	87.6	-	87.9	87.6	83.8	86.9	-	82.1	85.8	77.9	334.6
347.8	78.3	79.6	-	85.1	86.2	81.4	82.9	-	79.4	81.6	75.4	78.3	-	73.9	76.9	69.9	347.8
360.9	70.7	72.0	-	77.5	78.7	73.4	75.0	-	71.4	72.8	67.6	69.2	-	66.1	67.9	62.2	360.9
374.0	63.7	64.9	-	70.3	71.5	66.4	67.5	-	64.3	65.5	60.3	61.5	-	58.6	60.0	54.9	374.0
387.1	57.1	58.0	-	63.7	64.6	59.7	60.8	-	57.5	58.9	53.6	54.9	-	51.6	53.1	47.8	387.1
400.3	50.7	51.6	-	57.5	58.3	53.7	54.7	-	51.4	52.5	47.5	48.7	-	45.7	47.0	41.8	400.3
413.4	44.8	45.6	-	51.6	52.2	47.8	48.6	-	45.7	46.5	41.7	42.8	-	40.1	41.1	36.2	413.4
426.5	39.2	39.9	-	45.9	46.5	42.1	42.8	-	40.1	40.8	36.2	37.0	-	34.6	35.5	30.9	426.5
439.6	34.1	34.6	-	40.7	41.2	37.0	37.6	-	35.0	35.6	31.2	31.9	-	29.5	30.4	24.5	439.6
452.8	29.1	29.6	-	35.8	36.2	32.0	32.7	-	30.0	30.6	26.2	26.9	-	23.8	24.5	17.2	452.8
465.9	24.5	24.9	-	31.1	31.5	27.3	28.0	-	25.4	25.8	21.6	22.0	-	17.6	18.1	10.1	465.9
469.2	23.4	-	-	30.0	30.5	26.2	26.9	-	24.3	24.7	20.2	20.8	-	16.1	16.6	8.6	469.2
472.4	22.4	-	-	29.0	29.5	25.2	25.8	-	23.2	23.7	18.7	19.5	-	14.6	15.1	-	472.4
479.0	20.3	-	-	26.9	-	23.1	23.6	-	21.1	21.5	15.9	16.9	-	11.5	12.2	-	479.0
482.3	-	-	-	25.8	-	22.0	22.5	-	20.0	20.5	14.4	15.6	-	9.9	10.7	-	482.3
485.6	-	-	-	24.7	-	20.9	-	-	19.0	19.4	13.0	14.3	-	8.4	9.3	-	485.6
488.8	-	-	-	23.8	-	20.0	-	-	18.0	18.5	11.8	13.1	-	7.9	-	-	488.8
492.1	-	-	-	-	-	19.1	-	-	17.0	-	10.6	11.8	-	-	-	-	492.1
495.4	-	-	-	-	-	18.1	-	-	16.1	-	9.4	10.6	-	-	-	-	495.4
498.7	-	-	-	-	-	17.2	-	-	15.1	-	8.2	-	-	-	-	-	498.7
505.3	-	-	-	-	-	-	-	-	13.2	-	-	-	-	-	-	-	505.3

	0 lb	143,300 lb	209,500 lb	275,600 lb	363,800 lb	452,000 lb	584,300 lb	716,600 lb
--	------	------------	------------	------------	------------	------------	------------	------------

Operation

LSL+LF

363,800 lb + 110,200 lb		36.1-68.9 ft		27.6 ft		32.2 ft/s		360°		ASME B30.5											
236.2 ft		255.9 ft		275.6 ft		295.3 ft		305.1 ft		LSL+LF_2											
0 lb		0-716.6 klb		0 lb		0-716.6 klb		0 lb		0-716.6 klb											
15°		20°		30°		15°		20°		30°											
ft		1,000 lb										ft									
52.5	190.7	190.7	-	-	-	-	-	-	-	-	-	-	-	-	52.5						
55.8	185.2	185.2	-	-	186.3	187.4	-	-	187.4	188.5	-	-	-	-	55.8						
59.1	179.7	179.7	140.0	-	180.8	183.0	-	-	183.0	184.1	-	-	184.1	185.2	-	59.1					
62.3	174.7	174.7	136.7	-	176.4	178.0	137.8	-	178.6	179.7	138.9	-	179.7	180.8	-	62.3					
65.6	169.8	169.8	133.4	-	172.0	173.1	134.5	-	174.2	175.3	136.7	-	175.3	176.4	137.8	-	65.6				
68.9	164.8	164.8	130.1	-	167.6	168.7	131.7	-	169.8	170.9	133.4	-	171.4	172.5	135.0	-	68.9				
72.2	159.8	159.8	126.8	83.6	163.1	164.2	129.0	84.0	165.3	166.4	130.1	-	167.6	168.7	132.3	-	72.2				
75.5	156.0	156.0	124.0	82.2	159.3	159.8	126.2	82.7	162.0	162.6	127.3	82.9	164.2	165.3	129.5	83.1	172.0	128.4	173.6	129.0	75.5
78.7	152.1	152.1	121.3	80.9	155.4	155.4	123.5	81.4	158.7	158.7	124.6	81.6	160.9	162.0	126.8	82.0	167.6	125.7	169.8	126.8	78.7
85.3	144.4	144.4	115.7	78.5	147.7	147.7	117.9	78.9	152.1	152.1	120.2	79.4	154.3	154.3	122.4	79.8	160.4	121.3	162.0	122.4	85.3
91.9	137.8	137.8	111.3	76.1	141.1	141.1	113.5	76.7	145.5	145.5	115.7	77.4	148.8	148.8	117.9	77.8	153.2	116.8	154.3	117.9	91.9
98.4	131.2	131.2	107.6	73.9	135.6	135.6	109.8	74.7	138.9	138.9	111.3	75.2	141.1	142.2	113.5	75.8	147.2	113.0	148.3	114.0	98.4
111.5	120.9	120.9	100.1	69.7	125.3	125.3	102.4	70.8	124.2	128.6	104.4	71.5	121.3	131.9	106.6	72.3	135.6	105.7	137.2	106.7	111.5
124.7	110.5	111.9	93.3	66.0	112.6	116.0	95.8	67.1	109.4	119.4	98.0	68.0	104.0	122.7	100.2	68.9	125.7	99.3	127.9	100.3	124.7
137.8	100.1	104.3	87.3	62.6	97.4	107.8	89.9	63.7	94.6	111.3	92.2	64.8	89.3	114.6	94.1	65.7	117.6	93.8	119.4	94.7	137.8
150.9	87.0	97.7	82.5	59.8	84.2	101.2	85.0	60.9	82.1	104.6	87.2	62.0	77.8	107.7	89.3	62.9	110.2	88.6	111.3	89.5	150.9
164.0	75.5	91.7	78.0	57.2	72.5	95.1	80.4	58.3	70.5	98.4	82.6	59.5	66.9	101.4	84.8	60.3	104.1	84.2	105.5	85.2	164.0
177.2	65.5	86.4	74.1	54.9	62.2	89.5	76.3	56.0	60.0	92.8	78.5	57.1	56.7	95.7	80.7	58.0	98.3	80.2	99.8	81.2	177.2
190.3	57.2	81.9	70.7	53.0	53.9	85.0	72.9	54.1	51.6	88.1	75.0	55.0	48.1	91.0	77.0	56.1	93.0	76.5	94.4	77.4	190.3
203.4	49.8	77.7	67.6	51.2	46.4	80.8	69.7	52.2	44.0	83.8	71.7	53.2	40.5	86.6	73.7	54.2	88.5	73.4	89.9	74.3	203.4
216.5	43.2	74.1	64.8	49.6	39.7	76.9	66.8	50.5	37.3	79.8	68.8	51.6	33.7	82.5	70.8	52.5	84.4	70.5	85.8	71.4	216.5
229.7	37.8	71.0	62.5	48.4	34.1	73.7	64.3	49.2	31.8	76.4	66.3	50.1	28.1	79.1	68.1	51.0	80.7	67.7	82.0	68.6	229.7
242.8	32.8	68.2	60.3	47.3	29.0	70.8	62.1	48.0	26.7	73.3	63.9	48.9	23.1	75.8	65.7	49.7	77.5	65.5	78.6	66.2	242.8
249.3	30.5	66.9	59.4	46.7	26.7	69.4	61.1	47.5	24.4	71.9	62.8	48.4	20.8	74.3	64.6	49.1	75.8	64.4	76.9	65.0	249.3
255.9	28.2	65.7	58.4	-	24.5	68.1	60.2	47.0	22.0	70.5	61.7	47.8	18.5	72.8	63.5	48.5	74.4	63.3	75.5	64.1	255.9
262.5	26.3	64.7	57.7	-	22.6	66.9	59.4	46.5	20.1	69.3	60.8	47.4	16.5	71.5	62.5	48.0	73.0	62.3	74.1	63.1	262.5
269.0	24.4	63.6	57.0	-	20.6	65.8	58.6	-	18.2	68.0	60.0	47.0	14.6	70.3	61.6	47.5	71.7	61.3	72.8	62.2	269.0
275.6	22.5	62.6	56.2	-	18.7	64.6	57.8	-	16.3	66.8	59.1	46.5	12.6	69.0	60.6	47.0	70.5	60.5	71.6	61.3	275.6
278.9	21.6	62.2	-	-	17.9	64.2	57.5	-	15.5	66.3	58.8	46.3	11.7	68.5	60.3	46.8	69.9	60.1	71.0	60.8	278.9
282.2	20.7	61.7	-	-	17.1	63.7	57.1	-	14.6	65.8	58.4	-	10.9	67.9	59.9	46.6	69.3	59.7	70.4	60.4	282.2
285.4	19.8	61.3	-	-	16.3	63.3	56.8	-	13.8	65.4	58.1	-	10.1	67.4	59.5	46.5	68.7	59.3	69.8	60.0	285.4
292.0	-	-	-	-	14.7	62.4	56.2	-	12.1	64.4	57.4	-	8.4	66.4	58.8	46.1	67.6	58.6	68.7	59.3	292.0
295.3	-	-	-	-	13.9	61.9	-	-	11.2	63.9	57.1	-	-	65.7	58.4	-	67.0	58.3	68.2	59.0	295.3
301.8	-	-	-	-	12.3	61.3	-	-	9.8	63.1	56.5	-	-	64.8	57.8	-	66.0	57.7	67.2	58.2	301.8
308.4	-	-	-	-	-	-	-	-	8.4	62.3	56.0	-	-	63.9	57.1	-	65.0	57.1	66.1	57.5	308.4
311.7	-	-	-	-	-	-	-	-	7.7	61.9	-	-	-	63.5	56.8	-	64.7	56.8	65.7	57.3	311.7
321.5	-	-	-	-	-	-	-	-	-	60.8	-	-	-	62.4	56.0	-	63.6	56.0	64.4	56.5	321.5
324.8	-	-	-	-	-	-	-	-	-	-	-	-	-	62.1	55.8	-	63.2	55.8	63.9	56.3	324.8
334.6	-	-	-	-	-	-	-	-	-	-	-	-	-	61.1	-	-	62.1	-	62.9	55.6	334.6
337.9	-	-	-	-	-	-	-	-	-	-	-	-	-	60.6	-	-	61.7	-	62.6	-	337.9
344.5	-	-	-	-	-	-	-	-	-	-	-	-	-	-	-	-	-	-	61.9	-	344.5







LSL+LF_2: 36.1 ft – 62.3 ft

LSL+LF_14: 42.7 ft – 68.9 ft

LSL+LF_14: 496,100 lb + 110,200 lb

Operation

LSL+LF

363,800 lb +  110,200 lb		 36.1-68.9 ft		 27.6 ft		 32.2 ft/s		360°		ASME B30.5						
315.0 ft				324.8 ft				334.6 ft				344.5 ft				
LSL+LF_2				LSL+LF_14				LSL+LF_2				LSL+LF_4				
0 lb				0-716.6 klb				0 lb				0-716.6 klb				
15°				20°				30°				15°				
ft																
1,000 lb																
59.1	184.1	185.2	-	-	-	-	-	-	-	-	-	-	-	-	59.1	
62.3	180.2	181.3	-	-	192.9	-	194.0	-	180.8	183.0	-	-	-	195.1	-	62.3
65.6	176.4	177.5	137.8	-	188.5	-	189.6	-	177.5	178.6	-	-	-	190.7	-	65.6
68.9	172.5	173.6	135.6	-	184.1	134.5	185.2	135.6	174.2	175.3	136.7	-	-	125.7	186.3	68.9
72.2	168.7	169.8	133.4	-	179.7	132.3	180.8	132.3	170.9	172.0	134.5	-	-	123.5	181.9	72.2
78.7	162.0	163.1	127.9	82.0	170.9	126.8	172.0	127.9	164.2	165.3	130.1	82.2	-	119.0	174.2	78.7
85.3	155.4	156.5	123.5	79.8	163.7	122.4	164.8	123.5	155.4	158.7	125.7	80.2	-	115.7	167.0	85.3
91.9	148.8	151.0	119.0	77.8	156.5	117.9	157.6	119.0	142.2	153.2	121.3	78.3	-	111.3	159.8	91.9
98.4	136.7	145.5	115.7	76.1	150.5	114.1	151.6	115.2	130.1	147.7	116.8	76.5	-	108.7	153.8	98.4
111.5	117.4	135.2	108.7	72.7	138.9	107.3	140.5	108.2	111.6	137.4	110.2	73.3	-	102.4	142.2	111.5
124.7	100.5	125.7	102.2	69.5	129.0	101.3	130.6	102.2	95.2	128.2	104.0	70.2	-	96.8	132.3	124.7
137.8	86.0	116.8	96.3	66.6	120.9	95.8	122.0	96.6	80.9	120.2	98.1	67.2	-	91.9	123.8	137.8
150.9	74.7	110.5	91.3	63.8	113.5	90.6	114.6	91.5	69.7	113.5	93.3	64.6	-	87.5	115.7	150.9
164.0	64.3	104.5	86.7	61.2	107.1	86.2	108.5	87.1	59.7	107.3	88.7	62.1	-	83.4	109.9	164.0
177.2	54.9	98.8	82.5	58.9	101.2	82.2	102.7	83.0	50.7	101.4	84.4	59.7	-	79.6	104.2	177.2
190.3	46.4	93.8	78.9	57.0	95.9	78.5	97.2	79.4	42.6	96.6	80.8	57.7	-	76.2	98.8	190.3
203.4	38.7	89.2	75.6	55.1	91.3	75.3	92.7	76.1	35.2	92.0	77.4	55.9	-	73.0	94.1	203.4
216.5	32.0	85.1	72.5	53.4	87.2	72.2	88.4	73.1	28.4	87.7	74.3	54.2	-	69.9	89.7	216.5
229.7	26.4	81.6	69.9	51.9	83.3	69.4	84.4	70.3	22.7	84.1	71.7	52.6	-	67.4	85.8	229.7
242.8	21.2	78.3	67.4	50.5	80.0	67.1	81.1	68.0	17.6	80.6	69.2	51.2	-	65.1	82.4	242.8
255.9	16.5	75.2	65.0	49.2	76.8	64.9	77.9	65.8	13.0	77.4	66.8	50.0	-	63.1	79.2	255.9
269.0	12.6	72.5	63.1	48.1	73.9	62.8	75.0	63.7	9.0	74.7	64.7	48.9	-	61.3	76.3	269.0
272.3	11.6	71.9	62.6	47.9	73.2	62.4	74.3	63.2	7.9	74.1	64.2	48.6	-	60.8	75.6	272.3
282.2	8.8	70.1	61.4	47.2	71.4	61.1	72.4	61.8	-	72.2	62.8	47.8	-	59.5	73.6	282.2
285.4	7.9	69.6	61.0	47.0	70.8	60.6	71.8	61.4	-	71.7	62.4	47.6	-	59.1	73.0	285.4
295.3	-	67.9	59.7	46.5	69.1	59.7	70.2	60.3	-	69.9	61.1	47.0	-	57.8	71.2	295.3
305.1	-	66.4	58.6	45.9	67.5	58.6	68.6	59.2	-	68.3	60.0	46.4	-	56.8	69.6	305.1
308.4	-	65.8	58.3	-	67.0	58.2	68.1	58.9	-	67.8	59.6	46.2	-	56.4	69.0	308.4
321.5	-	64.0	57.0	-	65.3	57.0	66.2	57.5	-	65.9	58.3	45.6	-	55.2	67.1	321.5
334.6	-	62.4	56.0	-	63.7	56.0	64.5	56.4	-	64.2	57.1	-	-	54.0	65.3	334.6
344.5	-	61.5	55.3	-	62.7	55.3	63.4	55.8	-	63.1	56.3	-	-	53.2	64.2	344.5
347.8	-	61.2	-	-	62.4	-	63.1	55.6	-	62.7	56.1	-	-	53.0	63.7	347.8
351.1	-	60.9	-	-	62.1	-	62.7	55.3	-	62.3	55.8	-	-	52.7	63.4	351.1
354.3	-	60.6	-	-	61.7	-	62.4	-	-	61.9	55.6	-	-	52.5	63.1	354.3
360.9	-	-	-	-	-	-	61.8	-	-	61.4	55.1	-	-	49.2	62.5	360.9
364.2	-	-	-	-	-	-	61.5	-	-	61.1	-	-	-	-	62.2	364.2
367.5	-	-	-	-	-	-	-	-	-	60.7	-	-	-	-	61.9	367.5
370.7	-	-	-	-	-	-	-	-	-	60.4	-	-	-	-	61.5	370.7
374.0	-	-	-	-	-	-	-	-	-	-	-	-	-	-	-	374.0
380.6	-	-	-	-	-	-	-	-	-	-	-	-	-	-	-	380.6



LSL+LF_2 – LSL+LF_4:  36.1 ft – 62.3 ft

LSL+LF_14:  42.7 ft – 68.9 ft

LSL+LF_14:  496,100 lb +  110,200 lb

Operation

LSL+LF

363,800 lb +  110,200 lb		36.1-68.9 ft		27.6 ft		32.2 ft/s		360°		ASME B30.5											
354.3 ft		364.2 ft		374.0 ft		78.7 ft		0 lb		0-716.6 klb											
LSL+LF_2		LSL+LF_4		LSL+LF_14		LSL+LF_4		LSL+LF_14		LSL+LF_2											
15°		20°		30°		15°		20°		15°											
ft		1,000 lb										ft									
62.3	176.4	181.9	-	-	-	-	-	-	-	-	-	-	-	-	62.3						
65.6	175.3	178.6	-	-	-	-	192.9	-	-	-	194.0	-	170.9	176.4	-	-	-	-	194.0	-	65.6
68.9	173.6	175.8	136.7	-	-	126.8	188.5	-	-	-	189.6	-	170.3	175.3	-	-	-	-	190.1	-	68.9
72.2	172.0	173.1	134.5	-	-	124.6	184.1	134.5	-	124.6	185.2	134.5	169.8	174.2	135.6	-	-	124.6	186.3	135.6	72.2
78.7	163.1	167.6	130.1	-	-	120.2	176.4	130.1	-	121.3	177.5	130.1	156.5	168.7	131.2	-	-	121.3	178.6	131.2	78.7
82.0	156.0	164.2	128.4	81.4	-	118.5	172.8	127.9	-	119.0	173.9	128.1	149.4	165.9	129.0	-	-	119.0	175.3	129.0	82.0
85.3	148.8	160.9	126.8	80.5	-	116.8	169.2	125.7	-	116.8	170.3	126.2	142.2	163.1	126.8	80.7	-	116.8	172.0	126.8	85.3
91.9	135.6	155.4	122.4	78.7	-	112.4	162.0	121.3	-	113.5	163.1	122.4	129.0	157.6	123.5	78.9	-	113.5	165.3	122.4	91.9
98.4	123.5	149.9	119.0	76.9	-	110.0	156.0	117.4	-	110.2	157.6	118.5	117.9	152.1	120.2	77.2	-	110.2	159.3	119.0	98.4
111.5	105.4	140.4	112.0	73.7	-	104.0	145.0	110.6	-	104.6	146.6	111.6	99.9	142.6	113.5	74.2	-	105.1	147.7	112.4	111.5
124.7	89.3	131.5	105.6	70.7	-	98.5	135.6	104.6	-	99.3	136.7	105.5	83.8	133.7	107.4	71.4	-	100.0	137.8	106.3	124.7
137.8	75.2	123.5	99.9	67.9	-	93.5	127.1	99.1	-	94.1	128.2	99.9	69.9	125.7	101.6	68.6	-	95.0	129.3	100.8	137.8
150.9	64.2	116.1	95.0	65.3	-	89.2	119.0	94.1	-	90.0	120.2	94.8	59.2	118.3	96.6	65.9	-	90.9	121.3	95.7	150.9
164.0	54.2	109.6	90.5	62.8	-	85.2	112.7	89.7	-	86.1	113.5	90.5	49.4	112.0	92.1	63.5	-	87.0	115.4	91.3	164.0
177.2	45.4	104.1	86.2	60.6	-	81.4	106.9	85.6	-	82.5	107.7	86.5	40.6	106.7	88.0	61.3	-	83.3	109.6	87.2	177.2
190.3	38.2	99.1	82.5	58.6	-	78.0	101.4	81.8	-	79.1	102.7	82.7	33.5	101.6	84.3	59.2	-	80.0	104.1	83.6	190.3
203.4	31.2	94.4	79.1	56.7	-	74.8	96.7	78.6	-	75.8	98.0	79.4	26.9	96.9	80.8	57.3	-	76.7	99.2	80.3	203.4
216.5	24.3	90.2	76.1	54.9	-	71.9	92.3	75.5	-	72.8	93.6	76.4	20.7	92.6	77.6	55.6	-	73.6	94.7	77.2	216.5
229.7	18.7	86.5	73.3	53.4	-	69.2	88.2	72.8	-	70.1	89.5	73.6	15.0	88.8	74.8	54.1	-	71.0	90.6	74.3	229.7
242.8	13.5	83.0	70.7	52.0	-	66.8	84.8	70.3	-	67.7	86.0	71.1	9.6	85.2	72.3	52.7	-	68.5	87.1	71.8	242.8
246.1	12.3	82.2	70.1	51.7	-	66.2	84.0	69.6	-	67.1	85.1	70.5	8.4	84.3	71.7	52.4	-	67.9	86.2	71.2	246.1
255.9	8.8	79.8	68.3	50.7	-	64.6	81.5	67.9	-	65.5	82.6	68.7	-	81.8	69.9	51.4	-	66.1	83.8	69.4	255.9
269.0	-	76.9	66.3	49.5	-	62.8	78.5	65.9	-	63.6	79.6	66.6	-	79.0	67.7	50.2	-	64.2	80.7	67.2	269.0
282.2	-	74.2	64.3	48.5	-	61.1	75.8	64.0	-	61.7	76.8	64.7	-	76.3	65.6	49.1	-	62.5	77.9	65.3	282.2
295.3	-	71.9	62.4	47.6	-	59.3	73.3	62.2	-	60.0	74.2	62.9	-	73.6	63.7	48.1	-	60.8	75.3	63.6	295.3
308.4	-	69.7	60.9	46.7	-	57.8	71.0	60.6	-	58.5	71.9	61.3	-	71.5	62.2	47.2	-	59.3	73.0	61.9	308.4
321.5	-	67.6	59.5	46.0	-	56.5	68.9	59.3	-	57.1	69.9	59.9	-	69.4	60.6	46.4	-	57.8	70.9	60.5	321.5
334.6	-	65.7	58.0	45.4	-	55.1	67.0	58.1	-	55.8	67.9	58.5	-	67.5	59.3	45.9	-	56.4	68.8	59.1	334.6
347.8	-	64.2	57.0	-	-	54.1	65.3	56.9	-	54.7	66.1	57.3	-	65.7	58.0	45.3	-	55.3	67.0	57.8	347.8
351.1	-	63.9	56.7	-	-	53.8	65.0	56.7	-	54.3	65.8	57.1	-	65.3	57.7	45.2	-	55.0	66.6	57.5	351.1
360.9	-	62.8	56.0	-	-	53.1	63.9	56.0	-	53.6	64.7	56.4	-	64.2	56.9	-	-	54.2	65.5	56.9	360.9
374.0	-	61.5	55.1	-	-	52.2	62.7	55.3	-	52.7	63.3	55.6	-	62.8	56.0	-	-	53.1	64.0	56.0	374.0
377.3	-	61.2	55.1	-	-	49.8	62.4	55.1	-	52.5	63.1	55.5	-	62.5	55.8	-	-	53.0	63.7	55.8	377.3
383.9	-	60.7	-	-	-	-	61.8	-	-	52.0	62.5	55.1	-	61.9	55.4	-	-	52.6	63.1	55.3	383.9
387.1	-	60.4	-	-	-	-	61.5	-	-	-	62.2	54.9	-	61.7	55.3	-	-	52.4	62.6	55.1	387.1
393.7	-	-	-	-	-	-	-	-	-	-	61.6	-	-	61.1	54.9	-	-	48.5	62.2	54.9	393.7
397.0	-	-	-	-	-	-	-	-	-	-	61.3	-	-	60.8	-	-	-	-	61.9	-	397.0
400.3	-	-	-	-	-	-	-	-	-	-	-	-	-	60.5	-	-	-	-	61.6	-	400.3
406.8	-	-	-	-	-	-	-	-	-	-	-	-	-	60.0	-	-	-	-	61.1	-	406.8

 0 lb 143,300 lb 209,500 lb 275,600 lb 363,800 lb 452,000 lb 584,300 lb 716,600 lb





LSL+LF_2 – LSL+LF_4:  36.1 ft – 62.3 ft

LSL+LF_14:  42.7 ft – 68.9 ft

LSL+LF_14:  496,100 lb +  110,200 lb

Operation

LSL+LF

363,800 lb +  110,200 lb		 36.1-68.9 ft		 27.6 ft		 32.2 ft/s		360°		ASME B30.5							
383.9 ft				393.7 ft				403.5 ft									
LSL+LF_4		LSL+LF_14		LSL+LF_2		LSL+LF_4		LSL+LF_14		LSL+LF_14							
78.7 ft																	
0-716.6 klb				0 lb		0-716.6 klb											
15°		20°		15°		20°		30°		15°		20°		15°		20°	
1,000 lb																	
ft																	ft
65.6	-	-	196.2	-	-	-	-	-	-	-	-	-	-	-	-	-	65.6
68.9	-	-	192.4	-	158.7	165.3	-	-	-	192.9	-	-	-	194.0	-	-	68.9
72.2	-	125.7	188.5	-	158.7	164.2	134.5	-	-	189.6	-	-	-	190.7	-	-	72.2
75.5	-	123.5	184.1	133.4	153.2	163.1	132.3	-	-	123.5	185.7	134.5	-	123.5	186.8	134.5	75.5
78.7	-	121.3	179.7	131.2	151.0	162.0	130.1	-	-	122.4	181.9	132.3	-	122.4	183.0	132.3	78.7
85.3	-	117.9	173.1	127.3	136.7	158.7	126.8	80.5	-	117.9	174.7	127.9	-	119.0	175.8	128.4	85.3
91.9	-	114.6	166.4	123.5	124.6	156.5	123.5	78.7	-	114.6	167.6	123.5	-	115.7	168.7	124.6	91.9
98.4	-	111.3	160.4	119.6	113.5	152.1	121.3	77.2	-	112.4	161.5	120.2	-	112.4	162.6	120.7	98.4
111.5	-	106.0	149.4	112.8	95.8	144.0	114.6	74.4	-	106.9	150.5	113.5	-	107.4	151.6	114.1	111.5
124.7	-	100.9	139.4	106.9	80.0	136.0	108.6	71.7	-	101.6	140.5	107.5	-	102.5	142.2	108.5	124.7
137.8	-	95.9	130.8	101.6	66.4	127.9	103.2	69.2	-	96.8	131.9	102.2	-	97.7	133.7	103.0	137.8
150.9	-	91.8	123.5	96.6	55.8	121.3	98.2	66.6	-	92.5	124.6	97.2	-	93.5	125.7	97.9	150.9
164.0	-	87.9	116.8	92.2	46.2	115.0	93.6	64.2	-	88.6	117.9	93.0	-	89.7	119.0	93.6	164.0
177.2	-	84.2	110.8	88.0	37.5	109.1	89.5	61.9	-	84.9	111.9	88.9	-	86.0	113.1	89.6	177.2
190.3	-	80.8	105.4	84.2	30.4	104.0	85.8	59.9	-	81.6	106.5	85.1	-	82.6	107.8	85.8	190.3
203.4	-	77.7	100.5	81.0	24.0	99.2	82.4	58.1	-	78.5	101.8	81.9	-	79.4	103.0	82.5	203.4
216.5	-	74.7	96.0	78.0	18.1	94.8	79.1	56.4	-	75.4	97.3	78.8	-	76.5	98.4	79.4	216.5
229.7	-	71.9	91.9	75.2	12.6	91.0	76.4	54.8	-	72.8	93.0	75.8	-	73.9	94.1	76.5	229.7
239.5	-	70.0	89.1	73.2	8.8	88.2	74.3	53.7	-	70.8	90.2	73.9	-	71.9	91.4	74.6	239.5
242.8	-	69.4	88.2	72.5	-	87.4	73.7	53.4	-	70.3	89.3	73.2	-	71.3	90.5	74.0	242.8
255.9	-	67.0	84.9	70.1	-	84.0	71.2	52.0	-	67.9	85.9	70.9	-	68.8	87.0	71.6	255.9
269.0	-	65.1	81.8	67.9	-	81.1	69.0	50.9	-	65.8	82.7	68.6	-	66.7	83.8	69.2	269.0
282.2	-	63.3	79.0	66.0	-	78.3	66.9	49.8	-	63.9	79.9	66.7	-	64.8	81.0	67.3	282.2
295.3	-	61.7	76.4	64.2	-	75.6	65.0	48.7	-	62.4	77.3	64.8	-	63.1	78.3	65.5	295.3
308.4	-	60.0	73.9	62.4	-	73.3	63.4	47.8	-	60.8	74.7	63.1	-	61.6	75.8	63.7	308.4
321.5	-	58.5	71.7	61.1	-	71.2	61.9	47.0	-	59.3	72.6	61.6	-	59.9	73.5	62.2	321.5
334.6	-	57.1	69.7	59.6	-	69.2	60.4	46.3	-	57.8	70.5	60.2	-	58.4	71.4	60.8	334.6
347.8	-	55.9	67.9	58.4	-	67.5	59.1	45.7	-	56.6	68.6	58.9	-	57.2	69.4	59.3	347.8
360.9	-	54.7	66.3	57.4	-	65.8	57.9	45.2	-	55.3	67.0	57.8	-	55.9	67.7	58.3	360.9
364.2	-	54.5	65.9	57.1	-	65.4	57.7	45.0	-	55.1	66.6	57.6	-	55.7	67.2	58.0	364.2
374.0	-	53.8	64.7	56.4	-	64.2	56.9	-	-	54.2	65.5	56.8	-	54.9	66.1	57.2	374.0
387.1	-	52.9	63.3	55.6	-	62.9	56.0	-	-	53.4	63.9	55.8	-	53.9	64.6	56.2	387.1
400.3	-	52.0	62.3	54.9	-	61.7	55.2	-	-	52.6	62.8	55.2	-	53.0	63.4	55.5	400.3
403.5	-	13.9	62.0	48.3	-	61.4	55.1	-	-	52.4	62.5	55.1	-	52.8	63.1	55.3	403.5
410.1	-	-	61.5	-	-	60.9	54.7	-	-	52.0	61.9	54.7	-	52.5	62.6	55.0	410.1
413.4	-	-	61.3	-	-	60.6	-	-	-	-	61.7	-	-	52.2	62.3	54.9	413.4
419.9	-	-	-	-	-	60.2	-	-	-	-	61.3	-	-	18.5	61.8	54.7	419.9
423.2	-	-	-	-	-	60.0	-	-	-	-	61.1	-	-	-	61.5	-	423.2
426.5	-	-	-	-	-	-	-	-	-	-	-	-	-	-	61.3	-	426.5
429.8	-	-	-	-	-	-	-	-	-	-	-	-	-	-	61.1	-	429.8



LSL+LF_2 – LSL+LF_4:  36.1 ft – 62.3 ft

LSL+LF_14:  42.7 ft – 68.9 ft

LSL+LF_14:  496,100 lb +  110,200 lb

Operation

LSL+LF

363,800 lb + 110,200 lb 36.1-68.9 ft 27.6 ft 32.2 ft/s 360° ASME B30.5																					
413.4 ft						423.2 ft						433.1 ft									
LSL+LF_2		LSL+LF_4		LSL+LF_14		LSL+LF_4		LSL+LF_14		LSL+LF_2		LSL+LF_4		LSL+LF_14							
78.7 ft																					
0 lb		0-716.6 klb												0 lb		0-716.6 klb					
15°		20°		30°		15°		20°		15°		20°		15°		20°					
ft	1,000 lb																		ft		
68.9	144.4	151.0	-	-	-	-	194.0	-	-	-	-	196.2	-	-	-	-	-	-	68.9		
72.2	144.4	149.9	-	-	-	-	189.6	-	-	-	-	191.8	-	131.2	135.6	-	-	-	72.2		
75.5	142.2	149.9	129.0	-	-	137.8	186.3	135.6	-	137.8	187.9	-	131.2	135.0	-	-	-	189.0	75.5		
78.7	141.1	149.9	127.9	-	-	135.6	183.0	133.4	-	135.6	184.1	133.4	131.2	134.5	120.2	-	-	135.6	185.2	133.4	78.7
85.3	132.3	148.8	125.7	-	-	132.3	176.4	129.0	-	132.3	177.5	129.5	125.7	133.4	120.2	-	-	132.3	178.6	129.5	85.3
88.6	126.2	148.8	124.6	79.4	-	130.6	173.1	126.8	-	130.6	174.2	127.6	120.2	133.4	119.6	79.1	-	130.6	175.3	127.6	88.6
91.9	120.2	148.8	123.5	78.7	-	129.0	169.8	124.6	-	129.0	170.9	125.7	115.7	133.4	119.0	78.5	-	129.0	172.0	125.7	91.9
98.4	110.2	147.7	120.2	77.2	-	125.7	163.7	121.3	-	125.7	164.8	121.8	105.8	132.3	117.9	77.2	-	125.7	166.4	122.4	98.4
111.5	92.6	141.1	115.0	74.4	-	119.0	152.7	114.6	-	119.0	153.8	115.2	88.5	130.1	114.3	74.7	-	119.0	155.4	115.7	111.5
124.7	77.1	134.5	109.8	71.7	-	113.4	143.3	108.8	-	114.4	144.4	109.7	73.2	127.5	110.0	72.1	-	114.5	145.5	110.0	124.7
137.8	63.7	127.9	104.5	69.2	-	108.7	134.8	103.8	-	109.6	136.0	104.4	60.0	124.6	105.2	69.4	-	109.8	137.1	105.1	137.8
150.9	53.1	122.0	99.6	66.9	-	104.3	126.8	98.8	-	105.0	127.9	99.4	49.7	120.9	100.6	67.1	-	105.2	129.0	100.1	150.9
164.0	43.6	116.1	95.2	64.6	-	100.1	120.2	94.4	-	100.8	121.3	95.0	40.3	116.8	96.3	64.9	-	101.0	122.4	95.8	164.0
177.2	35.1	110.2	91.1	62.4	-	96.1	114.2	90.3	-	96.8	115.4	91.0	32.0	112.4	92.2	62.8	-	97.2	116.5	91.8	177.2
190.3	28.1	105.7	87.4	60.5	-	92.4	108.9	86.6	-	93.1	110.2	87.3	25.1	108.2	88.6	60.9	-	93.5	111.3	88.0	190.3
203.4	21.8	101.2	83.9	58.6	-	88.9	104.1	83.3	-	89.7	105.2	83.9	18.7	103.8	85.2	59.2	-	90.1	106.3	84.6	203.4
216.5	15.9	96.8	80.7	56.9	-	85.5	99.5	80.1	-	86.4	100.5	80.8	12.8	99.2	82.0	57.5	-	86.9	101.6	81.5	216.5
229.7	10.9	92.7	77.9	55.4	-	82.7	95.2	77.2	-	83.6	96.3	78.0	7.7	94.5	79.2	56.0	-	84.1	97.4	78.7	229.7
236.2	8.4	90.8	76.5	54.7	-	81.4	93.4	75.9	-	82.2	94.5	76.7	-	92.2	77.8	55.3	-	82.7	95.6	77.4	236.2
242.8	-	89.2	75.3	54.0	-	80.1	91.6	74.6	-	81.0	92.7	75.4	-	90.5	76.6	54.6	-	81.4	93.8	76.1	242.8
255.9	-	86.0	72.8	52.7	-	77.6	88.1	72.2	-	78.5	89.1	72.9	-	87.1	74.1	53.1	-	78.9	90.3	73.6	255.9
269.0	-	83.0	70.5	51.4	-	75.4	84.9	69.9	-	76.1	85.8	70.5	-	84.3	71.9	52.0	-	76.7	86.9	71.2	269.0
282.2	-	80.2	68.4	50.2	-	73.3	81.9	68.0	-	73.9	83.0	68.7	-	81.7	69.7	50.9	-	74.6	83.9	69.2	282.2
295.3	-	77.6	66.4	49.2	-	71.2	79.2	66.1	-	71.9	80.2	66.7	-	79.1	67.7	49.8	-	72.5	81.1	67.2	295.3
308.4	-	75.3	64.6	48.3	-	69.3	76.7	64.4	-	70.0	77.6	64.8	-	76.7	65.9	48.8	-	70.7	78.5	65.5	308.4
321.5	-	73.0	63.0	47.5	-	67.6	74.4	62.8	-	68.2	75.3	63.4	-	74.6	64.2	47.9	-	68.9	76.1	63.9	321.5
334.6	-	70.8	61.5	46.7	-	65.9	72.3	61.3	-	66.6	73.1	61.9	-	72.5	62.6	47.2	-	67.2	74.0	62.4	334.6
347.8	-	69.0	60.2	46.0	-	64.6	70.3	60.0	-	65.1	71.2	60.4	-	70.6	61.3	46.5	-	65.8	71.9	60.8	347.8
360.9	-	67.3	58.9	45.5	-	63.3	68.6	58.8	-	63.8	69.3	59.2	-	68.8	60.0	45.8	-	64.4	70.1	59.7	360.9
374.0	-	65.7	57.8	45.0	-	61.9	66.9	57.7	-	62.4	67.6	58.1	-	67.0	58.6	45.2	-	63.1	68.4	58.6	374.0
380.6	-	65.0	57.2	44.8	-	61.5	66.1	57.2	-	61.9	66.9	57.6	-	66.4	58.2	45.1	-	62.5	67.6	58.1	380.6
387.1	-	64.2	56.7	-	-	61.0	65.3	56.7	-	61.4	66.1	57.1	-	65.6	57.7	44.9	-	61.9	66.8	57.5	387.1
393.7	-	63.5	56.2	-	-	60.4	64.7	56.2	-	60.8	65.4	56.7	-	64.8	57.1	44.5	-	61.3	66.1	57.1	393.7
400.3	-	62.9	55.9	-	-	60.0	64.1	55.8	-	60.4	64.7	56.2	-	64.2	56.7	-	-	60.8	65.3	56.7	400.3
413.4	-	61.7	55.1	-	-	59.1	62.9	55.0	-	59.5	63.3	55.4	-	62.8	55.8	-	-	60.0	62.9	55.8	413.4
426.5	-	60.7	54.5	-	-	58.4	61.7	54.5	-	58.8	59.1	54.7	-	61.8	55.0	-	-	59.2	57.1	55.1	426.5
436.4	-	60.0	-	-	-	-	59.3	-	-	52.9	55.2	45.6	-	61.1	54.5	-	-	58.7	53.1	52.9	436.4
439.6	-	59.7	-	-	-	-	58.0	-	-	-	53.9	-	-	60.8	54.4	-	-	58.6	51.8	52.1	439.6
442.9	-	-	-	-	-	-	-	-	-	-	52.7	-	-	60.6	54.2	-	-	58.4	50.5	51.4	442.9
446.2	-	-	-	-	-	-	-	-	-	-	51.4	-	-	60.4	27.8	-	-	-	49.2	-	446.2
449.5	-	-	-	-	-	-	-	-	-	-	50.0	-	-	60.2	-	-	-	-	48.0	-	449.5
452.8	-	-	-	-	-	-	-	-	-	-	-	-	-	60.0	-	-	-	-	46.8	-	452.8
456.0	-	-	-	-	-	-	-	-	-	-	-	-	-	59.7	-	-	-	-	45.6	-	456.0

0 lb
 143,300 lb
 209,500 lb
 275,600 lb
 363,800 lb
 452,000 lb
 584,300 lb
 716,600 lb

LSL+LF_2 – LSL+LF_4: 36.1 ft – 62.3 ft

LSL+LF_14: 42.7 ft – 68.9 ft

LSL+LF_14: 496,100 lb + 110,200 lb

Operation

LSL+LF

363,800 lb + 110,200 lb 36.1-68.9 ft 27.6 ft 32.2 ft/s 360° ASME B30.5																	
442.9 ft				452.8 ft								462.6 ft					
LSL+LF_4		LSL+LF_14		LSL+LF_2				LSL+LF_4		LSL+LF_14		LSL+LF_4		LSL+LF_14			
78.7 ft																	
0-716.6 klb				0 lb				0-716.6 klb									
15°		20°		15°		20°		15°		20°		15°		20°		15°	20°
1,000 lb																	
ft																ft	
72.2	-	-	194.0	-	114.6	119.0	-	-	-	192.9	-	-	-	196.2	-	72.2	
78.7	-	135.6	186.3	134.5	114.6	117.9	107.8	-	-	131.2	186.3	134.5	-	127.9	188.5	-	78.7
82.0	-	133.9	183.0	132.3	114.6	117.4	107.7	-	-	130.1	183.3	132.3	-	127.3	185.2	133.4	82.0
85.3	-	132.3	179.7	130.4	114.6	116.8	107.6	-	-	130.1	180.2	130.4	-	126.8	181.9	131.2	85.3
91.9	-	129.0	173.1	126.8	110.2	115.7	107.1	78.0	-	127.9	174.2	126.8	-	126.8	175.3	127.9	91.9
98.4	-	126.8	167.6	122.9	102.3	115.7	106.5	76.7	-	125.7	168.7	123.5	-	125.7	169.8	124.0	98.4
111.5	-	120.9	156.5	116.3	85.4	113.5	104.9	74.1	-	120.5	157.6	116.8	-	120.5	158.7	117.4	111.5
124.7	-	115.4	146.6	110.9	70.4	111.7	102.9	71.5	-	115.4	147.7	111.1	-	115.7	148.8	112.0	124.7
137.8	-	110.2	138.2	105.7	57.3	110.2	100.5	69.0	-	110.2	139.3	106.3	-	111.3	140.7	106.9	137.8
150.9	-	106.1	130.1	100.8	47.2	108.2	98.2	66.8	-	106.1	131.2	101.4	-	107.2	133.4	102.1	150.9
164.0	-	102.1	123.5	96.5	38.0	105.6	95.5	64.7	-	102.1	124.6	97.2	-	103.2	126.0	97.7	164.0
177.2	-	98.1	117.6	92.4	29.8	102.5	92.4	62.6	-	98.3	118.7	93.1	-	99.2	119.8	93.6	177.2
190.3	-	94.6	112.4	88.6	23.0	99.4	89.3	60.7	-	94.8	113.5	89.3	-	95.8	114.6	89.9	190.3
203.4	-	91.2	107.6	85.4	16.8	96.4	86.1	59.0	-	91.5	108.6	86.1	-	92.4	109.2	86.6	203.4
216.5	-	88.2	103.0	82.2	11.0	93.3	82.9	57.5	-	88.4	103.9	82.8	-	89.3	105.0	83.4	216.5
223.1	-	86.5	100.8	80.8	8.4	91.8	81.4	56.7	-	86.8	101.8	81.4	-	87.8	102.9	81.9	223.1
229.7	-	85.0	98.5	79.4	-	90.3	79.8	56.0	-	85.4	99.6	80.0	-	86.3	100.8	80.5	229.7
242.8	-	82.3	94.7	76.7	-	87.3	77.0	54.7	-	82.7	95.8	77.4	-	83.6	96.9	78.0	242.8
255.9	-	79.8	91.2	74.3	-	84.2	74.5	53.6	-	80.0	92.2	74.9	-	80.9	93.3	75.5	255.9
269.0	-	77.4	87.7	71.9	-	81.3	72.5	52.4	-	77.8	88.8	72.5	-	78.6	89.7	73.2	269.0
282.2	-	75.3	84.9	69.9	-	78.5	70.5	51.3	-	75.6	85.9	70.5	-	76.4	86.8	71.1	282.2
295.3	-	73.2	82.0	67.9	-	75.8	68.8	50.3	-	73.6	83.0	68.5	-	74.5	84.0	69.2	295.3
308.4	-	71.3	79.4	66.1	-	73.4	67.0	49.2	-	71.9	80.2	66.6	-	72.5	81.1	67.2	308.4
321.5	-	69.4	77.1	64.5	-	70.9	65.3	48.4	-	70.1	78.0	65.0	-	70.8	78.8	65.6	321.5
334.6	-	67.7	74.8	63.0	-	67.9	63.7	47.6	-	68.3	75.7	63.4	-	69.0	76.5	64.0	334.6
347.8	-	66.2	72.8	61.5	-	66.3	62.3	46.9	-	66.9	73.6	61.9	-	67.4	74.3	62.4	347.8
360.9	-	64.9	70.9	60.2	-	64.4	60.9	46.2	-	65.5	71.7	60.6	-	65.9	72.4	61.1	360.9
374.0	-	63.5	69.1	59.0	-	63.3	59.7	45.4	-	64.2	69.9	59.5	-	64.6	70.5	59.9	374.0
387.1	-	62.3	67.5	58.0	-	62.5	58.6	45.0	-	62.9	68.1	58.4	-	63.4	66.4	58.9	387.1
400.3	-	61.3	65.0	56.9	-	61.9	57.5	44.5	-	61.7	63.7	57.3	-	62.2	60.0	57.8	400.3
410.1	-	60.6	60.9	56.1	-	61.5	56.7	44.3	-	60.9	59.4	56.2	-	61.4	55.4	56.0	410.1
413.4	-	60.4	59.5	55.8	-	61.3	56.4	-	-	60.6	58.0	55.6	-	61.1	53.9	54.6	413.4
426.5	-	59.5	53.6	54.5	-	61.0	55.7	-	-	58.7	52.2	52.9	-	56.9	48.1	49.2	426.5
439.6	-	57.2	48.1	49.2	-	60.3	55.0	-	-	55.2	46.7	47.6	-	52.1	42.9	43.8	439.6
452.8	-	52.2	43.3	43.9	-	59.3	54.5	-	-	50.5	42.0	42.5	-	47.4	38.0	38.8	452.8
459.3	-	-	40.9	-	-	57.4	54.2	-	-	48.3	39.6	40.1	-	45.3	35.6	36.4	459.3
462.6	-	-	39.8	-	-	56.4	53.1	-	-	-	38.4	-	-	44.2	34.5	35.2	462.6
465.9	-	-	38.6	-	-	55.5	-	-	-	-	37.3	-	-	43.2	33.3	34.0	465.9
469.2	-	-	-	-	-	54.5	-	-	-	-	36.2	-	-	42.1	32.2	32.8	469.2
472.4	-	-	-	-	-	53.6	-	-	-	-	35.1	-	-	-	31.2	-	472.4
479.0	-	-	-	-	-	-	-	-	-	-	-	-	-	-	29.1	-	479.0
482.3	-	-	-	-	-	-	-	-	-	-	-	-	-	-	28.0	-	482.3

0 lb
 143,300 lb
 209,500 lb
 275,600 lb
 363,800 lb
 452,000 lb
 584,300 lb
 716,600 lb









LSL+LF_2 – LSL+LF_4: 36.1 ft – 62.3 ft

LSL+LF_14: 42.7 ft – 68.9 ft

LSL+LF_14: 496,100 lb + 110,200 lb

Operation

LSL+LF

     													
 472.4 ft 482.3 ft													
LSL+LF_2 LSL+LF_4 LSL+LF_14 LSL+LF_4 LSL+LF_14													
 78.7 ft													
 0 lb 0-716.6 klb													
15° 20° 30° 15° 20° 15° 20° 15° 20° 15° 20°													
ft	1,000 lb											ft	
75.5	101.0	104.5	-	-	-	-	192.9	-	-	-	191.8	-	75.5
78.7	100.8	104.1	-	-	-	-	189.6	-	-	-	190.7	-	78.7
82.0	100.5	103.6	95.7	-	-	121.3	186.3	133.4	-	116.8	187.4	133.4	82.0
85.3	100.3	103.2	95.5	-	-	120.2	183.0	131.2	-	116.8	184.1	131.7	85.3
91.9	99.4	102.3	95.0	76.7	-	120.2	176.4	127.9	-	116.8	177.5	127.9	91.9
98.4	97.2	101.4	94.4	75.6	-	120.2	170.3	124.6	-	116.8	171.4	124.6	98.4
111.5	81.1	99.6	93.2	73.1	-	117.2	159.3	117.9	-	115.4	160.4	118.5	111.5
124.7	66.6	97.9	91.9	70.7	-	113.9	149.9	112.3	-	113.2	151.0	113.0	124.7
137.8	53.8	96.1	90.4	68.3	-	110.2	141.8	107.5	-	110.2	142.6	107.9	137.8
150.9	43.8	94.4	88.9	66.1	-	106.0	134.5	102.5	-	106.6	134.5	103.2	150.9
164.0	34.7	92.4	87.2	64.1	-	102.0	127.1	98.3	-	102.8	127.9	98.9	164.0
177.2	26.5	90.2	85.1	62.2	-	98.3	120.9	94.3	-	99.0	122.0	94.9	177.2
190.3	19.7	87.8	82.7	60.4	-	95.0	115.7	90.6	-	95.8	116.8	91.3	190.3
203.4	13.5	85.5	80.5	58.7	-	91.8	110.3	87.1	-	92.4	111.5	87.9	203.4
216.5	7.9	83.3	78.3	57.1	-	88.8	106.0	84.1	-	89.5	107.1	84.7	216.5
229.7	-	81.1	75.9	55.8	-	86.1	101.6	81.1	-	86.7	102.7	81.8	229.7
242.8	-	78.9	73.6	54.5	-	83.2	97.8	78.5	-	84.1	98.9	79.1	242.8
255.9	-	76.5	71.4	53.1	-	80.7	94.2	76.1	-	81.6	95.1	76.7	255.9
269.0	-	74.0	69.2	52.1	-	78.5	90.8	73.6	-	79.1	91.7	74.3	269.0
282.2	-	71.6	67.0	51.0	-	76.2	87.7	71.7	-	77.1	88.6	72.3	282.2
295.3	-	69.2	65.0	50.0	-	74.3	84.8	69.7	-	75.0	85.7	70.3	295.3
308.4	-	67.0	63.3	49.2	-	72.5	82.0	67.7	-	73.2	82.9	68.3	308.4
321.5	-	64.7	61.5	48.4	-	71.0	79.7	66.1	-	71.6	80.5	66.6	321.5
334.6	-	61.9	60.0	47.6	-	69.4	77.4	64.5	-	70.1	78.3	65.0	334.6
347.8	-	60.4	57.6	47.0	-	68.0	75.2	63.1	-	68.4	76.1	63.5	347.8
360.9	-	58.3	56.4	46.4	-	66.5	73.3	61.7	-	67.0	72.5	62.2	360.9
374.0	-	57.1	55.3	45.9	-	65.0	70.8	60.4	-	65.7	67.3	60.8	374.0
387.1	-	56.1	54.1	45.3	-	63.9	64.2	59.3	-	64.4	60.4	59.7	387.1
400.3	-	55.3	53.6	44.8	-	62.2	57.8	57.1	-	61.7	54.1	54.9	400.3
413.4	-	54.7	53.1	44.3	-	60.0	51.7	53.0	-	56.9	48.1	49.5	413.4
426.5	-	54.2	52.8	39.0	-	54.6	46.1	47.2	-	51.7	42.3	43.7	426.5
439.6	-	53.9	52.7	-	-	49.7	40.8	41.9	-	46.8	37.0	38.4	439.6
452.8	-	53.6	52.7	-	-	45.0	35.8	36.8	-	41.9	32.0	33.3	452.8
465.9	-	52.0	52.0	-	-	40.6	31.1	32.0	-	37.6	27.3	28.4	465.9
475.7	-	50.0	50.5	-	-	37.5	27.9	28.7	-	34.5	24.1	25.0	475.7
479.0	-	49.1	41.2	-	-	-	26.9	-	-	33.6	23.1	23.9	479.0
485.6	-	47.3	-	-	-	-	24.7	-	-	15.7	20.9	21.8	485.6
492.1	-	45.4	-	-	-	-	22.7	-	-	-	19.1	-	492.1
498.7	-	-	-	-	-	-	-	-	-	-	17.2	-	498.7







LSL+LF_2 – LSL+LF_4: 

LSL+LF_14: 

LSL+LF_14: 

Operation

LSL+LF

363,800 lb +  110,200 lb		36.1-68.9 ft		27.6 ft		32.2 ft/s		360°		ASME B30.5													
492.1 ft		502.0 ft		511.8 ft		521.7 ft		531.5 ft		541.3 ft													
LSL+LF_4		LSL+LF_14		LSL+LF_4		LSL+LF_14		LSL+LF_4		LSL+LF_14													
78.7 ft																							
0 lb		0-716.6 klb				0 lb		0-716.6 klb															
20°		15°		20°		15°		20°		15°													
1,000 lb																							
75.5	-	-	188.5	-	-	-	181.9	-	-	-	-	75.5											
78.7	-	-	188.5	-	-	-	181.9	-	-	-	-	78.7											
82.0	99.6	103.4	186.0	-	-	100.3	180.8	-	-	-	175.8	82.0											
85.3	99.6	103.2	183.5	132.3	-	100.1	179.7	132.3	92.8	95.9	175.3	133.4	-	92.6	169.2	133.4	163.9	-	157.3	-	85.3		
88.6	98.0	103.1	181.1	130.6	-	99.9	178.6	131.2	91.5	95.7	174.7	131.2	-	92.5	168.9	131.2	163.5	132.3	156.9	132.3	156.5	130.1	91.9
91.9	97.9	103.0	178.6	129.0	-	99.6	177.5	129.0	91.5	95.5	174.2	129.0	-	92.4	168.7	130.1	163.1	130.1	156.5	130.1	156.5	130.1	91.9
98.4	92.8	102.5	172.5	125.7	-	99.2	172.5	125.7	87.3	95.0	171.4	125.7	-	91.9	167.6	126.8	162.0	126.8	155.4	127.3	155.4	127.3	98.4
111.5	76.2	101.2	161.5	119.0	-	98.0	162.6	119.6	71.0	94.0	163.7	119.6	-	90.9	163.1	120.7	158.7	120.7	153.2	121.3	153.2	121.3	111.5
124.7	61.6	99.7	152.1	113.0	-	96.8	153.2	114.1	56.6	92.8	154.3	114.1	-	89.8	155.4	115.2	153.8	115.2	150.5	115.7	150.5	115.7	124.7
137.8	48.9	98.1	143.7	108.1	-	95.5	144.8	109.0	44.1	91.5	145.9	109.2	-	88.6	147.0	110.1	147.3	110.2	146.2	111.2	146.2	111.2	137.8
150.9	38.8	96.5	135.6	103.8	-	93.8	136.7	104.3	34.1	90.0	137.8	104.9	-	87.3	138.9	105.4	140.0	105.8	141.1	106.5	141.1	106.5	150.9
164.0	29.6	94.7	129.0	99.6	-	92.3	130.1	100.0	25.1	88.6	131.2	100.7	-	86.0	132.3	101.1	133.4	101.7	134.5	102.2	134.5	102.2	164.0
177.2	21.4	92.8	123.1	95.5	-	90.8	123.8	96.0	17.0	87.1	124.9	96.7	-	84.7	126.3	97.2	127.3	97.8	127.9	98.2	127.9	98.2	177.2
190.3	14.6	90.2	117.9	91.7	-	88.8	117.9	92.4	10.1	85.5	119.0	93.0	-	83.3	120.2	93.5	121.3	94.1	122.4	94.6	122.4	94.6	190.3
193.6	12.9	89.5	116.5	90.9	-	88.3	116.8	91.5	8.4	85.1	117.9	92.2	-	83.0	118.9	92.7	120.0	93.3	121.1	93.8	121.1	93.8	193.6
203.4	8.2	87.7	112.4	88.4	-	86.8	113.5	89.0	-	83.8	114.6	89.6	-	81.9	115.0	90.2	116.1	90.8	117.2	91.3	117.2	91.3	203.4
216.5	-	85.3	108.0	85.4	-	84.9	109.1	86.0	-	82.2	110.2	86.5	-	80.5	110.6	87.2	111.6	87.6	112.6	88.3	112.6	88.3	216.5
229.7	-	83.0	103.6	82.5	-	83.0	104.7	82.9	-	80.8	105.6	83.6	-	79.1	106.7	84.2	107.6	84.7	108.5	85.3	108.5	85.3	229.7
242.8	-	80.8	99.8	79.8	-	81.1	100.8	80.2	-	79.0	101.7	80.9	-	77.8	102.7	81.6	103.6	82.0	104.5	82.7	104.5	82.7	242.8
255.9	-	78.7	96.1	77.3	-	79.4	97.0	77.8	-	77.6	98.0	78.4	-	76.5	99.0	79.0	99.9	79.5	100.8	80.1	100.8	80.1	255.9
269.0	-	76.8	92.6	75.0	-	77.2	93.5	75.4	-	75.4	94.6	76.1	-	74.5	95.5	76.5	96.3	77.2	97.2	77.6	97.2	77.6	269.0
282.2	-	74.7	89.5	72.8	-	75.6	90.4	73.4	-	73.9	91.4	73.9	-	72.8	92.3	74.5	93.1	75.0	94.0	75.5	94.0	75.5	282.2
295.3	-	73.0	86.6	70.8	-	73.9	87.5	71.4	-	72.3	88.4	71.9	-	71.0	89.2	72.5	90.1	72.9	90.9	73.4	90.9	73.4	295.3
308.4	-	71.3	83.8	68.8	-	71.8	84.7	69.4	-	70.2	85.5	69.9	-	69.7	86.4	70.5	87.3	71.0	88.0	71.4	88.0	71.4	308.4
321.5	-	69.6	81.4	67.2	-	70.3	82.2	67.7	-	68.6	83.0	68.1	-	67.8	83.8	68.8	84.7	69.2	85.5	69.7	85.5	69.7	321.5
334.6	-	68.1	78.9	65.6	-	68.8	79.8	66.0	-	67.2	80.6	66.6	-	66.6	81.4	67.1	82.1	67.5	82.0	68.0	82.0	68.0	334.6
347.8	-	66.6	76.7	63.9	-	67.2	77.6	64.4	-	65.3	78.3	65.0	-	65.3	79.1	65.5	79.6	65.9	75.2	66.4	75.2	66.4	347.8
360.9	-	65.4	74.8	62.6	-	65.7	75.5	63.1	-	63.6	74.9	63.6	-	63.6	73.6	64.1	71.9	64.5	67.8	63.4	67.8	63.4	360.9
374.0	-	64.4	71.8	61.4	-	64.4	70.5	61.8	-	62.4	69.0	62.3	-	62.4	65.7	61.7	64.2	61.3	60.5	59.2	60.5	59.2	374.0
387.1	-	62.9	66.4	60.2	-	63.5	62.4	60.6	-	61.4	60.6	60.8	-	60.6	57.8	58.4	56.4	56.4	53.1	53.6	53.1	53.6	387.1
400.3	-	61.9	60.2	59.0	-	61.8	56.4	57.0	-	59.7	54.6	55.6	-	57.4	50.6	52.2	49.3	50.3	45.8	47.0	45.8	47.0	400.3
413.4	-	61.1	54.3	55.6	-	58.6	50.5	52.2	-	55.8	48.8	50.1	-	52.7	44.9	46.5	43.1	44.6	39.4	40.9	39.4	40.9	413.4
426.5	-	56.3	48.5	50.0	-	53.4	45.0	46.5	-	50.6	43.2	44.3	-	47.5	39.5	40.8	37.7	39.0	34.0	35.3	34.0	35.3	426.5
439.6	-	51.4	43.4	44.8	-	48.4	39.7	41.1	-	45.7	38.1	39.0	-	42.6	34.3	35.5	32.6	33.7	28.7	30.2	28.7	30.2	439.6
452.8	-	46.5	38.4	39.7	-	43.7	34.7	35.9	-	41.0	33.1	34.0	-	37.9	29.4	30.4	27.7	28.7	23.2	25.1	23.2	25.1	452.8
465.9	-	42.1	33.5	34.8	-	39.2	30.0	31.1	-	36.6	28.2	29.1	-	33.7	24.7	25.6	22.9	24.0	17.2	20.3	17.2	20.3	465.9
479.0	-	38.0	29.2	30.4	-	35.1	25.4	26.7	-	32.5	23.8	24.7	-	29.5	20.3	21.2	18.7	19.5	11.5	15.9	11.5	15.9	479.0
485.6	-	36.1	27.1	28.2	-	33.2	23.4	24.5	-	30.6	21.6	22.5	-	27.6	18.1	19.0	16.5	17.2	8.6	13.7	8.6	13.7	485.6
492.1	-	34.2	25.1	26.0	-	31.3	21.4	22.4	-	28.7	19.6	20.5	-	25.6	16.1	16.9	14.4	15.2	-	10.4	-	10.4	492.1
495.4	-	-	24.2	-	-	30.4	20.4	21.4	-	27.7	18.6	19.5	-	24.7	15.1	15.9	13.3	14.2	-	8.8	-	8.8	495.4
502.0	-	-	22.3	-	-	28.4	18.4	19.4	-	25.9	16.6	17.5	-	22.9	13.1	13.8	11.2	12.2	-	-	-	-	502.0
508.5	-	-	20.3	-	-	-	16.5	-	-	24.0	14.8	15.4	-	21.2	11.2	11.6	8.8	9.6	-	-	-	-	508.5
511.8	-	-	-	-	-	-	15.7	-	-	-	13.9	-	-	20.3	10.3	10.4	-	7.9	-	-	-	-	511.8
515.1	-	-	-	-	-	-	14.8	-	-	-	13.0	-	-	19.4	9.3	9.3	-	-	-	-	-	-	515.1
518.4	-	-	-	-	-	-	-	-	-	-	12.1	-	-	8.4	-	8.4	-	-	-	-	-	-	518.4
524.9	-	-	-	-	-	-	-	-	-	-	10.4	-	-	-	-	-	-	-	-	-	-	-	524.9

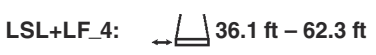

Operation

LSL+LF

363,800 lb +		110,200 lb		36.1-62.3 ft			27.6 ft			32.2 ft/s			360°			ASME B30.5							
236.2 ft		255.9 ft			275.6 ft			295.3 ft			315.0 ft			LSL+LF_2									
118.1 ft																							
0 lb		0-716.6 klb		0 lb		0-716.6 klb		0 lb		0-716.6 klb		0 lb		0-716.6 klb		0 lb		0-716.6 klb					
15°		20°		30°		15°		20°		30°		15°		20°		30°		15°		20°		30°	
ft		1,000 lb																				ft	
65.6	114.6	114.6	-	-	-	-	-	-	-	-	-	-	-	-	-	-	-	-	-	-	-	-	65.6
68.9	111.8	112.0	-	-	112.4	112.4	-	-	112.4	113.5	-	-	-	-	-	-	-	-	-	-	-	-	68.9
72.2	108.9	109.3	-	-	109.8	110.2	-	-	110.2	110.2	-	-	110.2	111.3	-	-	-	-	-	-	-	-	72.2
75.5	106.3	106.7	84.7	-	107.3	107.7	-	-	107.8	108.1	-	-	108.2	109.1	-	-	108.7	109.3	-	-	-	-	75.5
78.7	103.6	104.1	82.9	-	104.7	105.2	83.3	-	105.4	106.0	83.6	-	106.3	106.9	-	-	106.5	107.1	-	-	-	-	78.7
82.0	101.2	101.6	81.1	-	102.3	102.8	81.6	-	103.1	103.7	81.9	-	104.1	104.6	82.2	-	104.4	104.9	82.2	-	-	-	82.0
85.3	98.8	99.2	79.4	-	99.9	100.5	79.8	-	100.8	101.4	80.2	-	101.9	102.3	80.7	-	102.3	102.7	80.9	-	-	-	85.3
91.9	94.4	95.0	76.1	-	95.7	96.1	76.7	-	96.8	97.2	77.4	-	97.7	98.3	77.8	-	98.3	99.0	78.0	-	-	-	91.9
95.1	92.4	92.9	74.6	48.1	93.8	94.2	75.4	48.1	94.9	95.3	75.9	-	95.9	96.5	76.5	-	96.6	97.1	76.7	-	-	-	95.1
98.4	90.4	90.8	73.2	47.4	91.9	92.4	74.1	47.4	93.0	93.5	74.5	47.4	94.1	94.6	75.2	47.4	94.8	95.2	75.4	-	-	-	98.4
101.7	88.6	89.0	71.9	46.7	90.2	90.6	72.8	46.7	91.3	91.8	73.3	46.8	92.5	93.0	74.0	46.8	93.3	93.7	74.3	46.7	-	-	101.7
111.5	83.3	83.6	68.0	44.6	85.0	85.3	69.1	44.8	86.3	86.7	69.8	44.9	87.7	88.1	70.6	45.0	88.6	88.9	71.0	45.0	-	-	111.5
124.7	76.9	77.1	63.3	42.0	78.6	78.9	64.4	42.3	80.1	80.5	65.4	42.5	81.6	82.1	66.3	42.8	82.8	83.0	66.9	42.8	-	-	124.7
137.8	71.0	71.2	59.1	39.7	72.8	73.0	60.2	39.9	74.5	74.7	61.3	40.3	76.1	76.5	62.2	40.6	77.4	77.6	63.1	40.8	-	-	137.8
150.9	66.3	66.5	55.6	37.6	68.0	68.3	56.7	38.0	69.7	70.0	57.8	38.4	71.4	71.7	58.8	38.8	71.8	72.9	59.7	39.0	-	-	150.9
164.0	62.2	62.5	52.4	35.8	63.9	64.1	53.5	36.2	65.3	65.8	54.6	36.7	66.2	67.3	55.6	37.1	65.6	68.6	56.5	37.3	-	-	164.0
177.2	58.6	59.1	49.6	34.2	60.2	60.4	50.7	34.6	61.5	61.9	51.8	35.1	60.6	63.5	52.7	35.5	57.8	64.6	53.6	35.7	-	-	177.2
190.3	55.7	56.0	47.3	32.8	56.2	57.6	48.5	33.3	55.2	59.0	49.5	33.7	53.0	60.4	50.5	34.2	50.4	61.4	51.1	34.2	-	-	190.3
203.4	51.8	53.1	45.0	31.6	50.8	54.8	46.3	32.0	48.6	56.2	47.3	32.5	45.6	57.6	48.4	32.9	43.4	58.4	48.8	33.0	-	-	203.4
216.5	47.0	50.3	43.0	30.4	43.9	52.0	44.1	30.9	41.7	53.6	45.2	31.3	38.6	55.1	46.3	31.7	36.8	55.8	46.7	32.0	-	-	216.5
229.7	41.4	47.9	41.2	29.4	38.1	49.7	42.3	29.8	35.9	51.2	43.4	30.3	32.8	52.8	44.5	30.7	31.1	53.4	45.0	30.9	-	-	229.7
242.8	36.2	45.7	39.5	28.5	32.9	47.5	40.6	28.9	30.7	49.0	41.7	29.3	27.6	50.5	42.8	29.8	25.8	51.2	43.3	30.0	-	-	242.8
255.9	31.5	43.7	37.9	27.8	28.2	45.4	39.0	28.0	26.0	47.0	40.1	28.4	22.7	48.3	41.2	28.9	20.9	49.2	41.7	29.1	-	-	255.9
269.0	27.4	41.9	36.6	27.0	24.1	43.5	37.7	27.4	21.9	45.0	38.8	27.7	18.6	46.4	39.8	28.1	16.8	47.3	40.2	28.4	-	-	269.0
282.2	23.7	40.3	35.4	26.6	20.4	41.8	36.4	26.9	18.2	43.3	37.6	27.1	14.8	44.6	38.4	27.5	13.0	45.5	38.9	27.6	-	-	282.2
288.7	22.0	39.5	34.9	26.5	18.7	41.1	35.9	26.7	16.5	42.5	37.0	26.9	13.0	43.8	37.8	27.2	11.2	44.7	38.3	27.3	-	-	288.7
295.3	20.3	38.8	34.4	-	17.0	40.3	35.3	26.5	14.8	41.7	36.4	26.7	11.2	43.0	37.3	26.9	9.5	43.9	37.7	26.9	-	-	295.3
301.8	18.8	38.2	34.0	-	15.4	39.7	34.8	26.2	13.2	41.0	35.8	26.5	9.7	42.4	36.7	26.7	7.9	43.2	37.3	26.7	-	-	301.8
308.4	17.3	37.6	33.5	-	13.9	39.0	34.4	-	11.7	40.3	35.2	26.2	8.2	41.7	36.2	26.5	-	42.4	36.7	26.5	-	-	308.4
315.0	15.9	37.0	33.1	-	12.3	38.4	34.0	-	10.1	39.7	34.6	26.0	-	40.8	35.7	26.2	-	41.7	36.2	26.2	-	-	315.0
321.5	14.6	36.6	-	-	11.1	37.8	33.5	-	8.8	39.1	34.3	-	-	40.2	35.2	26.1	-	41.1	35.7	26.1	-	-	321.5
324.8	13.9	36.4	-	-	10.5	37.6	33.3	-	8.2	38.8	34.1	-	-	39.9	34.9	26.0	-	40.8	35.5	26.0	-	-	324.8
331.4	-	-	-	-	9.2	37.1	32.8	-	-	38.2	33.7	-	-	39.3	34.4	25.8	-	40.2	35.1	25.9	-	-	331.4
334.6	-	-	-	-	8.6	36.8	-	-	-	37.9	33.5	-	-	39.0	34.2	-	-	39.9	34.8	25.8	-	-	334.6
337.9	-	-	-	-	7.9	36.6	-	-	-	37.7	33.3	-	-	38.8	34.0	-	-	39.6	34.6	25.7	-	-	337.9
341.2	-	-	-	-	7.3	36.4	-	-	-	37.4	33.2	-	-	38.5	33.8	-	-	39.4	34.5	25.6	-	-	341.2
344.5	-	-	-	-	-	-	-	-	-	37.1	33.0	-	-	38.3	33.6	-	-	39.1	34.3	25.6	-	-	344.5
347.8	-	-	-	-	-	-	-	-	-	36.9	32.8	-	-	38.0	33.4	-	-	38.9	34.1	-	-	-	347.8
357.6	-	-	-	-	-	-	-	-	-	36.2	-	-	-	37.3	32.9	-	-	38.1	33.6	-	-	-	357.6
360.9	-	-	-	-	-	-	-	-	-	-	-	-	-	37.0	32.8	-	-	37.9	33.4	-	-	-	360.9
364.2	-	-	-	-	-	-	-	-	-	-	-	-	-	36.8	32.6	-	-	37.7	33.3	-	-	-	364.2
374.0	-	-	-	-	-	-	-	-	-	-	-	-	-	36.2	-	-	-	37.0	32.8	-	-	-	374.0
380.6	-	-	-	-	-	-	-	-	-	-	-	-	-	-	-	-	-	36.7	32.6	-	-	-	380.6
387.1	-	-	-	-	-	-	-	-	-	-	-	-	-	-	-	-	-	36.3	-	-	-	-	387.1
393.7	-	-	-	-	-	-	-	-	-	-	-	-	-	-	-	-	-	35.9	-	-	-	-	393.7

	0 lb	143,300 lb	209,500 lb	275,600 lb	363,800 lb	452,000 lb	584,300 lb	716,600 lb
--	------	------------	------------	------------	------------	------------	------------	------------

Operation

LSL+LF

363,800 lb + 110,200 lb 36.1-62.3 ft 27.6 ft 32.2 ft/s 360° ASME B30.5												
433.1 ft 452.8 ft 472.4 ft LSL+LF_2 118.1 ft												
0 lb 0-716.6 klb 0 lb 0-716.6 klb 0 lb 0-716.6 klb												
15° 20° 30° 15° 20° 30° 15° 20° 30°												
ft	1,000 lb											ft
85.3	89.3	93.3	-	-	80.5	83.6	-	-	-	-	-	85.3
88.6	89.3	93.1	-	-	80.5	83.4	-	-	71.7	74.3	-	88.6
91.9	89.3	93.0	-	-	80.5	83.3	-	-	71.7	74.1	-	91.9
95.1	89.2	92.6	76.1	-	80.5	83.2	72.1	-	71.5	73.9	-	95.1
98.4	89.1	92.2	75.2	-	80.5	83.1	71.9	-	71.4	73.6	64.8	98.4
111.5	83.3	89.5	71.9	44.3	77.1	81.9	69.7	-	70.1	72.6	64.2	111.5
114.8	82.9	89.0	71.1	43.9	76.8	81.6	69.2	43.7	69.8	72.3	64.1	114.8
124.7	76.1	86.3	68.8	42.7	70.3	80.2	67.5	42.4	63.9	71.4	63.3	124.7
137.8	63.5	82.0	65.7	41.2	60.8	77.8	64.8	40.8	57.5	70.1	62.2	137.8
150.9	53.2	78.0	62.8	39.8	50.7	75.0	62.0	39.3	47.4	68.6	60.0	150.9
164.0	43.9	74.2	60.0	38.3	41.5	72.3	59.4	37.9	38.3	67.2	57.8	164.0
177.2	35.5	70.5	57.3	36.8	33.3	69.7	56.9	36.6	30.2	65.7	55.8	177.2
190.3	28.6	67.3	55.0	35.6	26.4	67.0	54.5	35.4	23.4	63.8	53.9	190.3
203.4	22.2	64.2	52.7	34.5	20.1	64.4	52.3	34.2	17.2	61.9	52.0	203.4
216.5	16.3	61.3	50.5	33.3	14.3	61.9	50.3	33.1	11.5	59.7	50.3	216.5
223.1	13.8	60.0	49.5	32.8	11.9	60.7	49.4	32.6	8.8	58.8	49.4	223.1
229.7	11.3	58.6	48.5	32.3	9.4	59.4	48.5	32.0	-	57.8	48.5	229.7
232.9	10.1	58.0	48.1	32.0	8.2	58.8	48.1	31.8	-	57.4	48.1	232.9
236.2	8.8	57.3	47.6	31.7	-	58.2	47.6	31.5	-	56.9	47.6	236.2
242.8	-	56.2	46.8	31.3	-	57.0	46.8	31.1	-	55.9	46.8	242.8
255.9	-	54.0	45.2	30.4	-	54.7	45.2	30.2	-	53.8	45.2	255.9
269.0	-	52.2	43.9	29.5	-	52.5	43.9	29.5	-	51.9	43.6	269.0
282.2	-	50.5	42.5	28.7	-	50.6	42.5	28.7	-	49.9	42.2	282.2
295.3	-	48.7	41.2	28.0	-	48.9	41.2	28.0	-	48.1	41.0	295.3
308.4	-	47.3	39.9	27.4	-	47.4	40.1	27.5	-	46.4	39.8	308.4
321.5	-	45.8	38.9	26.9	-	46.0	38.9	26.8	-	44.8	38.8	321.5
334.6	-	44.5	37.7	26.2	-	44.8	37.9	26.2	-	43.4	37.7	334.6
347.8	-	43.2	36.8	25.9	-	43.4	37.0	25.9	-	41.9	36.8	347.8
360.9	-	42.0	36.0	25.5	-	42.3	36.2	25.4	-	40.6	36.0	360.9
374.0	-	41.0	35.3	25.1	-	41.2	35.3	25.1	-	39.5	35.3	374.0
387.1	-	40.0	34.5	24.8	-	40.2	34.7	24.8	-	38.4	34.6	387.1
400.3	-	39.1	33.9	24.6	-	39.3	34.1	24.5	-	37.3	33.9	400.3
413.4	-	38.4	33.3	24.5	-	38.6	33.5	24.3	-	36.2	33.3	413.4
426.5	-	37.6	32.8	24.3	-	37.9	33.1	24.1	-	35.6	32.8	426.5
433.1	-	37.3	32.6	24.0	-	37.5	32.8	24.0	-	35.3	32.6	433.1
439.6	-	37.1	32.6	-	-	37.2	32.6	24.0	-	35.1	32.4	439.6
446.2	-	36.9	32.4	-	-	36.9	32.4	23.8	-	35.0	32.2	446.2
452.8	-	36.6	32.2	-	-	36.6	32.2	-	-	34.8	32.0	452.8
462.6	-	36.3	32.1	-	-	36.3	32.0	-	-	34.6	31.8	462.6
465.9	-	36.2	32.0	-	-	36.2	31.9	-	-	34.5	31.7	465.9
479.0	-	35.8	31.7	-	-	35.8	31.7	-	-	34.3	31.5	479.0
482.3	-	35.7	31.7	-	-	35.7	31.6	-	-	34.3	31.5	482.3
492.1	-	35.5	-	-	-	35.5	31.5	-	-	34.2	31.3	492.1
495.4	-	35.3	-	-	-	35.5	31.5	-	-	34.2	31.3	495.4
498.7	-	-	-	-	-	35.4	31.5	-	-	34.2	31.2	498.7
511.8	-	-	-	-	-	35.3	-	-	-	34.2	31.1	511.8
518.4	-	-	-	-	-	-	-	-	-	34.2	12.1	518.4
528.2	-	-	-	-	-	-	-	-	-	34.2	-	528.2

	0 lb	143,300 lb	209,500 lb	275,600 lb	363,800 lb	452,000 lb	584,300 lb	716,600 lb
--	------	------------	------------	------------	------------	------------	------------	------------

LUFFING FLY JIB



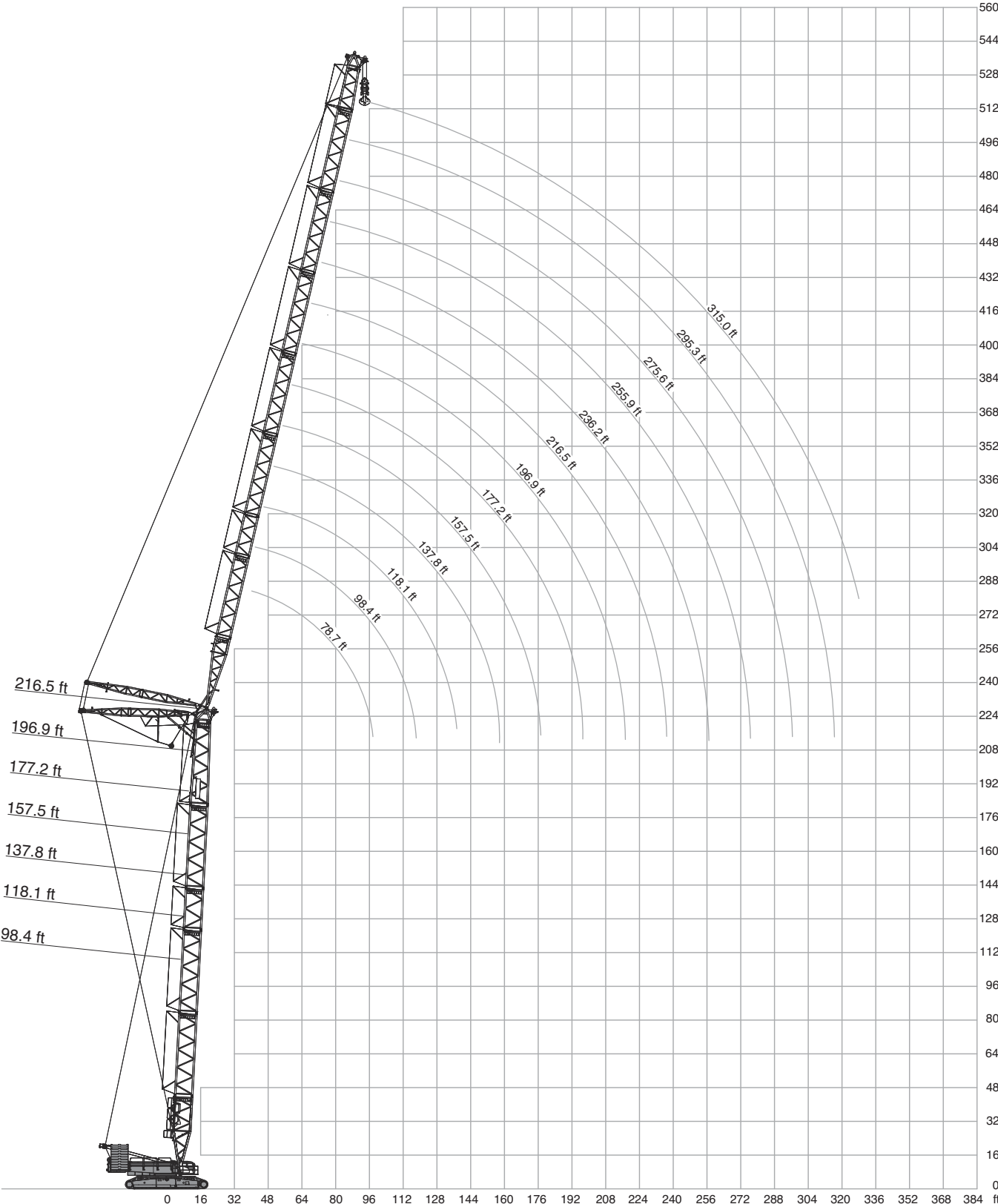

Operation

SW

452,000 lb + 110,200 lb		27.6 ft			32.2 ft/s			360°			ASME B30.5															
118.1 ft																										
78.7 ft				98.4 ft				118.1 ft				137.8 ft				157.5 ft										
SW_1																										
87°/85°			75°			65°			87°/85°			75°			65°			87°/85°			75°			65°		
ft									1,000 lb																	
36.1	597.5	-	-	-	-	-	-	-	-	-	-	-	-	-	-	-	-	-	-	-	-	-	-	-		
39.4	549.0	-	-	524.7	-	-	-	-	-	-	-	-	-	-	-	-	-	-	-	-	-	-	-	-		
45.9	471.8	-	-	454.2	-	-	-	434.3	-	-	-	-	-	-	-	-	-	-	-	-	-	-	-	-		
49.2	440.9	-	-	423.3	-	-	-	407.9	-	-	392.4	-	-	-	-	-	-	-	-	-	-	-	-	-		
52.5	414.5	-	-	399.0	-	-	-	383.6	-	-	370.4	-	-	-	-	-	-	-	-	-	-	-	-	-		
55.8	390.2	-	-	374.8	-	-	-	361.6	-	-	348.3	-	-	-	-	335.1	-	-	-	-	-	-	-	-		
59.1	368.2	-	-	354.9	-	-	-	341.7	-	-	330.7	-	-	-	-	317.5	-	-	-	-	-	-	-	-		
65.6	328.5	-	-	319.7	-	-	-	308.6	-	-	297.6	-	-	-	-	286.6	-	-	-	-	-	-	-	-		
72.2	288.8	-	-	284.4	-	-	-	280.0	-	-	271.2	-	-	-	-	260.1	-	-	-	-	-	-	-	-		
75.5	272.3	242.5	-	269.0	-	-	-	265.7	-	-	260.1	-	-	-	-	249.1	-	-	-	-	-	-	-	-		
78.7	255.7	229.3	-	253.5	-	-	-	251.3	-	-	249.1	-	-	-	-	238.1	-	-	-	-	-	-	-	-		
85.3	229.3	207.2	-	227.1	203.9	-	-	227.1	-	-	224.9	-	-	-	-	220.5	-	-	-	-	-	-	-	-		
91.9	205.0*	187.4	-	207.2	184.1	-	-	205.0	181.9	-	203.9	-	-	-	-	201.7	-	-	-	-	-	-	-	-		
98.4	-	170.9	-	188.5	167.6	-	-	187.4	165.3	-	186.3	-	-	-	-	184.1	-	-	-	-	-	-	-	-		
101.7	-	164.2	-	181.1	161.2	-	-	180.2	159.0	-	179.1	156.5	-	-	-	176.6	-	-	-	-	-	-	-	-		
108.3	-	151.0	135.6	166.4	148.5	-	-	165.9	146.3	-	164.8	144.0	-	-	-	161.8	141.1	-	-	-	-	-	-	-		
111.5	-	144.4	131.2	157.6*	142.2	-	-	158.7	140.0	-	157.6	137.8	-	-	-	154.3	134.5	-	-	-	-	-	-	-		
114.8	-	138.9	126.5	-	137.2	-	-	153.2	135.0	-	152.1	132.8	-	-	-	148.8	129.5	-	-	-	-	-	-	-		
118.1	-	-	121.8	-	132.3	117.9	-	147.7	130.1	-	146.6	127.9	-	-	-	143.3	124.6	-	-	-	-	-	-	-		
124.7	-	-	112.4	-	122.4	109.6	-	136.7	120.2	-	135.6	117.9	-	-	-	132.3	114.6	-	-	-	-	-	-	-		
131.2	-	-	105.7	-	114.6	102.4	-	125.7*	112.5	99.6	126.8	110.7	-	-	-	124.0	107.4	-	-	-	-	-	-	-		
134.5	-	-	102.3	-	-	98.8	-	-	108.7	96.3	122.4	107.0	-	-	-	119.9	103.7	-	-	-	-	-	-	-		
137.8	-	-	-	-	-	95.5	-	-	104.9	93.0	117.9	103.4	-	-	-	115.7	100.1	-	-	-	-	-	-	-		
141.1	-	-	-	-	-	92.7	-	-	101.9	90.2	114.6	100.3	88.4	-	-	112.3	97.0	-	-	-	-	-	-	-		
150.9	-	-	-	-	-	84.4	-	-	92.8	81.8	103.0*	91.1	80.0	-	-	102.1	87.7	-	-	-	-	-	-	-		
154.2	-	-	-	-	-	-	-	-	-	79.5	-	88.6	77.7	-	-	99.3	85.2	73.2	-	-	-	-	-	-		
164.0	-	-	-	-	-	-	-	-	-	72.8	-	81.1	70.5	-	-	91.1	77.6	66.1	-	-	-	-	-	-		
170.6	-	-	-	-	-	-	-	-	-	68.8	-	76.9	66.6	-	-	84.0*	73.4	62.2	-	-	-	-	-	-		
177.2	-	-	-	-	-	-	-	-	-	-	-	-	62.6	-	-	-	69.2	58.2	-	-	-	-	-	-		
190.3	-	-	-	-	-	-	-	-	-	-	-	-	56.4	-	-	-	62.4	51.6	-	-	-	-	-	-		
203.4	-	-	-	-	-	-	-	-	-	-	-	-	-	-	-	-	-	46.1	-	-	-	-	-	-		
210.0	-	-	-	-	-	-	-	-	-	-	-	-	-	-	-	-	-	43.9	-	-	-	-	-	-		

* Main boom angle 85°

Main boom angle 87°, 85°, 75° and 65°, capacities for intermediate boom positions are calculated by the crane control system IC-1

Operation

SW

452,000 lb + 110,200 lb		27.6 ft		32.2 ft/s		360°		ASME B30.5			
118.1 ft											
177.2 ft			196.9 ft			216.5 ft			236.2 ft		
SW_1											
87°/85° 75° 65°			87°/85° 75° 65°			87°/85° 75° 65°			87°/85° 75° 65°		
ft			1,000 lb								
59.1	306.4	-	-	-	-	-	-	-	-	-	
62.3	291.0	-	-	282.2	-	-	-	-	-	-	
65.6	277.8	-	-	266.8	-	-	-	-	-	-	
68.9	265.7	-	-	255.7	-	-	246.9	-	-	-	
72.2	253.5	-	-	244.7	-	-	235.9	-	-	218.3	
78.7	231.5	-	-	222.7	-	-	217.2	-	-	209.4	
85.3	213.8	-	-	206.1	-	-	200.6	-	-	192.9	
91.9	198.4	-	-	191.8	-	-	185.2	-	-	178.6	
98.4	183.0	-	-	177.5	-	-	172.0	-	-	166.4	
111.5	154.3	-	-	152.1	-	-	149.9	-	-	144.4	
118.1	143.3	123.5	-	141.1	-	-	139.4	-	-	135.6	
124.7	132.3	114.6	-	130.1	-	-	129.0	-	-	126.8	
128.0	127.9	110.8	-	125.9	108.5	-	124.6	-	-	122.6	
134.5	119.0	103.2	-	117.7	101.0	-	115.7	99.0	-	114.4	
137.8	114.6	99.4	-	113.5	97.2	-	111.3	95.5	-	110.2	
144.4	108.1	93.1	-	106.6	90.8	-	104.8	89.3	-	103.6	
150.9	101.6	87.1	-	99.6	84.7	-	98.3	83.1	-	97.0	
164.0	90.2	76.7	65.0	88.2	74.5	-	86.9	72.8	-	85.3	
173.9	83.1	70.4	59.1	80.9	67.9	56.0	79.6	66.1	-	78.0	
177.2	80.7	68.3	57.1	78.5	65.7	54.0	77.2	63.9	-	75.6	
187.0	72.5*	62.7	52.0	72.5	60.1	49.1	71.0	58.0	46.7	69.5	
190.3	-	60.8	50.3	70.5	58.2	47.4	69.0	56.2	45.2	67.5	
196.9	-	57.8	47.4	67.1	54.9	44.4	65.6	53.0	42.1	63.9	
203.4	-	54.7	44.5	63.7	51.8	41.4	62.2	49.8	39.5	60.4	
206.7	-	53.1	43.3	60.4*	50.4	40.2	60.7	48.4	38.2	58.9	
210.0	-	51.8	42.1	-	49.1	39.0	59.2	47.0	36.9	57.3	
216.5	-	-	39.7	-	46.3	36.6	56.2	44.1	34.4	54.2	
226.4	-	-	36.5	-	42.5	33.5	50.5*	40.5	31.1	50.1	
229.7	-	-	35.5	-	-	32.4	-	39.2	30.0	48.7	
242.8	-	-	-	-	-	28.7	-	35.1	26.2	42.1*	
246.1	-	-	-	-	-	27.8	-	34.2	25.5	41.0*	
255.9	-	-	-	-	-	-	-	-	23.1	-	
265.7	-	-	-	-	-	-	-	-	20.9	-	
269.0	-	-	-	-	-	-	-	-	-	-	
282.2	-	-	-	-	-	-	-	-	-	-	
285.4	-	-	-	-	-	-	-	-	-	-	

* Main boom angle 85°

Main boom angle 87°, 85°, 75° and 65°, capacities for intermediate boom positions are calculated by the crane control system IC-1

Operation

SW

452,000 lb + 110,200 lb		27.6 ft		32.2 ft/s		360°		ASME B30.5									
137.8 ft																	
78.7 ft			98.4 ft			118.1 ft			137.8 ft			157.5 ft					
SW_1																	
87°/85°			75°			65°			87°/85°			75°			65°		
ft			1,000 lb														
39.4	524.7	-	-	-	-	-	-	-	-	-	-	-	-	-			
42.7	485.0	-	-	465.2	-	-	-	-	-	-	-	-	-	-			
45.9	451.9	-	-	434.3	-	-	416.7	-	-	-	-	-	-	-			
49.2	423.3	-	-	407.9	-	-	390.2	-	-	377.0	-	-	-	-			
52.5	399.0	-	-	383.6	-	-	368.2	-	-	354.9	-	-	-	-			
55.8	374.8	-	-	361.6	-	-	348.3	-	-	335.1	-	-	321.9	-			
59.1	354.9	-	-	341.7	-	-	328.5	-	-	319.7	-	-	306.4	-			
65.6	319.7	-	-	308.6	-	-	297.6	-	-	288.8	-	-	277.8	-			
72.2	286.6	-	-	282.2	-	-	271.2	-	-	262.4	-	-	251.3	-			
78.7	253.5	-	-	251.3	-	-	249.1	-	-	240.3	-	-	231.5	-			
82.0	241.4	211.6	-	239.2	-	-	237.0	-	-	231.5	-	-	222.7	-			
85.3	229.3	200.6	-	227.1	-	-	224.9	-	-	222.7	-	-	213.8	-			
91.9	203.9*	181.9	-	205.0	178.6	-	203.9	-	-	202.8	-	-	198.4	-			
95.1	194.0*	173.6	-	196.2	170.3	-	195.1	-	-	194.0	-	-	190.7	-			
98.4	-	165.3	-	187.4	162.0	-	186.3	159.8	-	185.2	-	-	183.0	-			
108.3	-	146.3	-	165.3	143.0	-	164.8	140.8	-	163.7	138.9	-	160.7	-			
111.5	-	140.0	-	155.4*	136.7	-	157.6	134.5	-	156.5	133.4	-	153.2	-			
114.8	-	135.0	-	149.9*	132.0	-	152.1	129.8	-	151.0	128.4	-	148.0	124.6			
118.1	-	130.1	113.5	-	127.3	-	146.6	125.1	-	145.5	123.5	-	142.7	119.8			
124.7	-	-	106.0	-	117.9	-	135.6	115.7	-	134.5	113.5	-	132.3	110.2			
128.0	-	-	102.7	-	114.3	98.8	131.2	112.0	-	130.3	110.0	-	127.9	106.6			
131.2	-	-	99.3	-	110.6	95.5	123.5*	108.2	-	126.2	106.5	-	123.5	103.1			
137.8	-	-	92.6	-	103.2	89.1	-	100.8	86.2	117.9	99.4	-	114.6	95.9			
141.1	-	-	89.7	-	-	86.3	-	97.8	83.4	114.5	96.4	-	111.3	92.9			
150.9	-	-	-	-	-	78.0	-	88.8	75.2	101.6*	87.3	73.2	101.2	83.8			
157.5	-	-	-	-	-	73.6	-	84.0	70.7	-	82.5	68.6	95.7	78.9			
160.8	-	-	-	-	-	71.4	-	-	68.4	-	80.0	66.2	92.9	76.5			
164.0	-	-	-	-	-	-	-	-	66.1	-	77.6	63.9	90.2	74.1			
170.6	-	-	-	-	-	-	-	-	62.5	-	73.6	60.2	82.7*	69.9			
177.2	-	-	-	-	-	-	-	-	58.9	-	69.7	56.4	-	65.7			
180.4	-	-	-	-	-	-	-	-	57.3	-	-	55.0	-	63.9			
190.3	-	-	-	-	-	-	-	-	-	-	-	50.5	-	58.6			
193.6	-	-	-	-	-	-	-	-	-	-	-	49.2	-	57.1			
200.1	-	-	-	-	-	-	-	-	-	-	-	46.7	-	41.7			
203.4	-	-	-	-	-	-	-	-	-	-	-	-	-	40.6			
216.5	-	-	-	-	-	-	-	-	-	-	-	-	-	36.2			

* Main boom angle 85°

Main boom angle 87°, 85°, 75° and 65°, capacities for intermediate boom positions are calculated by the crane control system IC-1

Operation

SW

452,000 lb + 110,200 lb		27.6 ft		32.2 ft/s		360°		ASME B30.5											
137.8 ft																			
177.2 ft			196.9 ft			216.5 ft			236.2 ft										
SW_1																			
87°/85°			75°			65°			87°/85°			75°			65°				
ft			1,000 lb																
59.1	295.4	-	-	-	-	-	-	-	-	-	-	-	-	-	-	-	-	-	-
65.6	266.8	-	-	257.9	-	-	-	-	-	-	-	-	-	-	-	-	-	-	-
68.9	255.7	-	-	246.9	-	-	238.1	-	-	-	-	-	-	-	-	-	-	-	-
72.2	244.7	-	-	235.9	-	-	229.3	-	-	209.4	-	-	-	-	-	-	-	-	-
78.7	224.9	-	-	217.2	-	-	210.5	-	-	202.8	-	-	-	-	-	-	-	-	-
85.3	207.2	-	-	200.6	-	-	194.0	-	-	187.4	-	-	-	-	-	-	-	-	-
91.9	191.8	-	-	185.2	-	-	179.7	-	-	173.1	-	-	-	-	-	-	-	-	-
98.4	178.6	-	-	172.0	-	-	167.6	-	-	160.9	-	-	-	-	-	-	-	-	-
111.5	153.2	-	-	151.0	-	-	145.5	-	-	140.0	-	-	-	-	-	-	-	-	-
124.7	131.2	110.2	-	130.1	-	-	129.0	-	-	123.5	-	-	-	-	-	-	-	-	-
131.2	122.9	102.7	-	121.3	100.1	-	120.2	-	-	116.7	-	-	-	-	-	-	-	-	-
137.8	114.6	95.5	-	112.4	93.0	-	111.3	-	-	110.0	-	-	-	-	-	-	-	-	-
141.1	111.2	92.4	-	109.1	90.0	-	107.9	88.2	-	106.6	-	-	-	-	-	-	-	-	-
147.6	104.2	86.4	-	102.3	83.9	-	101.1	82.3	-	99.8	79.6	-	-	-	-	-	-	-	-
150.9	100.8	83.3	-	99.0	80.9	-	97.7	79.4	-	96.3	77.2	-	-	-	-	-	-	-	-
164.0	89.5	73.4	-	87.5	70.8	-	86.2	68.8	-	84.9	66.8	-	-	-	-	-	-	-	-
173.9	82.4	67.0	52.9	80.2	64.2	-	78.9	62.2	-	77.5	60.2	-	-	-	-	-	-	-	-
177.2	80.0	64.8	51.1	77.8	61.9	-	76.5	60.2	-	75.2	58.0	-	-	-	-	-	-	-	-
183.7	75.8	61.2	48.0	73.9	58.3	44.8	72.3	56.4	-	71.1	54.3	-	-	-	-	-	-	-	-
190.3	69.7*	57.5	44.8	69.9	54.7	41.7	68.3	52.7	-	67.0	50.7	-	-	-	-	-	-	-	-
193.6	-	55.9	43.2	68.2	53.1	40.3	66.6	51.1	37.9	65.3	49.1	-	-	-	-	-	-	-	-
203.4	-	51.1	39.2	63.1	48.5	36.2	61.5	46.5	34.0	60.0	44.3	-	-	-	-	-	-	-	-
206.7	-	49.9	38.1	59.4*	47.1	35.0	60.0	45.1	32.8	58.4	42.9	30.4	-	-	-	-	-	-	-
210.0	-	48.6	36.9	58.0*	45.7	33.8	58.5	43.8	31.6	56.9	41.5	29.2	-	-	-	-	-	-	-
213.3	-	47.4	35.8	-	44.4	32.7	57.0	42.4	30.5	55.3	40.1	28.1	-	-	-	-	-	-	-
216.5	-	-	34.6	-	43.0	31.5	55.6	41.0	29.3	53.8	38.8	26.9	-	-	-	-	-	-	-
226.4	-	-	31.6	-	39.7	28.5	49.4*	37.5	26.2	49.7	35.2	23.9	-	-	-	-	-	-	-
229.7	-	-	30.6	-	38.6	27.6	-	36.4	25.4	48.3	34.0	22.9	-	-	-	-	-	-	-
232.9	-	-	29.8	-	37.5	26.7	-	35.3	24.5	47.1	32.9	22.0	-	-	-	-	-	-	-
236.2	-	-	28.9	-	-	25.8	-	34.3	23.6	45.9	31.9	21.1	-	-	-	-	-	-	-
242.8	-	-	-	-	-	24.0	-	32.2	21.8	43.4	29.8	19.2	-	-	-	-	-	-	-
246.1	-	-	-	-	-	23.3	-	31.3	21.1	39.9*	28.9	18.4	-	-	-	-	-	-	-
252.6	-	-	-	-	-	21.9	-	29.5	19.5	-	27.1	16.9	-	-	-	-	-	-	-
255.9	-	-	-	-	-	21.2	-	-	18.7	-	26.2	16.1	-	-	-	-	-	-	-
269.0	-	-	-	-	-	-	-	-	16.1	-	22.9	13.2	-	-	-	-	-	-	-
272.3	-	-	-	-	-	-	-	-	15.4	-	22.3	12.6	-	-	-	-	-	-	-
275.6	-	-	-	-	-	-	-	-	15.0	-	-	12.0	-	-	-	-	-	-	-
282.2	-	-	-	-	-	-	-	-	-	-	-	10.8	-	-	-	-	-	-	-
292.0	-	-	-	-	-	-	-	-	-	-	-	9.3	-	-	-	-	-	-	-

* Main boom angle 85°

Main boom angle 87°, 85°, 75° and 65°, capacities for intermediate boom positions are calculated by the crane control system IC-1

Operation

SW

452,000 lb + 110,200 lb		27.6 ft		32.2 ft/s		360°		ASME B30.5			
137.8 ft											
255.9 ft		275.6 ft			295.3 ft			315.0 ft			
SW_1											
87°/85°		75°		65°		87°/85°		75°		65°	
ft				1,000 lb							
78.7	177.5	-	-	-	-	-	-	-	-	-	-
82.0	176.4	-	-	151.0	-	-	-	-	-	-	-
85.3	175.3	-	-	149.9	-	-	129.0	-	-	-	-
91.9	167.6	-	-	148.8	-	-	127.9	-	-	110.2	-
98.4	155.4	-	-	146.6	-	-	125.7	-	-	109.6	-
111.5	135.6	-	-	130.1	-	-	123.5	-	-	107.4	-
124.7	119.0	-	-	113.5	-	-	110.0	-	-	104.9	-
137.8	105.6	-	-	100.8	-	-	96.8	-	-	92.2	-
150.9	94.1	-	-	89.5	-	-	85.8	-	-	81.4	-
157.5	88.8	68.6	-	84.7	-	-	81.0	-	-	76.7	-
164.0	83.3	64.6	-	79.8	60.0	-	76.3	-	-	72.1	-
173.9	76.1	58.3	-	73.4	54.5	-	70.2	50.9	-	66.0	-
177.2	73.6	56.2	-	71.2	52.7	-	68.1	49.4	-	63.9	-
180.4	71.6	54.3	-	69.2	50.9	-	66.3	47.8	-	62.2	43.2
190.3	65.5	48.7	-	63.1	45.4	-	60.8	43.2	-	56.9	38.8
203.4	58.4	42.3	-	55.8	39.0	-	54.2	37.5	-	50.5	33.5
216.5	52.0	36.8	24.7	49.2	33.5	-	47.8	32.0	-	45.0	28.9
229.7	46.3	32.0	20.7	43.4	28.9	17.2	42.1	27.1	-	39.9	24.7
239.5	42.7	28.8	18.1	39.6	25.6	14.6	38.3	24.0	12.6	36.1	21.6
242.8	41.4	27.8	17.2	38.4	24.5	13.7	37.0	22.9	11.7	34.8	20.5
252.6	38.1	25.0	14.7	35.1	21.8	11.2	33.6	20.1	9.3	31.5	17.7
255.9	37.0	24.0	13.9	34.0	20.9	10.4	32.4	19.2	-	30.4	16.8
262.5	35.1	22.4	12.5	32.1	19.2	9.0	30.4	17.5	-	28.3	15.1
265.7	32.0*	21.6	11.7	31.1	18.3	-	29.4	16.7	-	27.3	14.3
269.0	-	20.7	11.0	30.2	17.4	-	28.4	15.9	-	26.2	13.4
278.9	-	18.6	9.0	27.6	15.2	-	25.8	13.6	-	23.6	11.1
282.2	-	17.9	-	24.7*	14.6	-	24.9	12.8	-	22.7	10.4
285.4	-	17.2	-	23.8*	13.9	-	24.1	12.1	-	21.9	9.7
288.7	-	16.5	-	-	13.2	-	23.3	11.5	-	21.1	9.0
295.3	-	-	-	-	11.9	-	21.6	10.1	-	19.4	-
301.8	-	-	-	-	10.8	-	18.3*	8.8	-	18.0	-
305.1	-	-	-	-	10.3	-	17.6*	-	-	17.3	-
308.4	-	-	-	-	9.7	-	-	-	-	16.5	-
321.5	-	-	-	-	-	-	-	-	-	11.9*	-

* Main boom angle 85°

Main boom angle 87°, 85°, 75° and 65°, capacities for intermediate boom positions are calculated by the crane control system IC-1

Operation

SW

452,000 lb + 110,200 lb		27.6 ft			32.2 ft/s			360°			ASME B30.5								
157.5 ft																			
78.7 ft				98.4 ft				118.1 ft				137.8 ft				157.5 ft			
SW_1																			
87°/85° 75° 65°				87°/85° 75° 65°				87°/85° 75° 65°				87°/85° 75° 65°							
ft				1,000 lb															
39.4	498.2	-	-	-	-	-	-	-	-	-	-	-	-						
42.7	463.0	-	-	445.3	-	-	-	-	-	-	-	-	-						
45.9	434.3	-	-	416.7	-	-	399.0	-	-	-	-	-	-						
52.5	381.4	-	-	368.2	-	-	354.9	-	-	341.7	-	-	-						
55.8	361.6	-	-	348.3	-	-	335.1	-	-	324.1	-	-	310.9						
59.1	341.7	-	-	328.5	-	-	317.5	-	-	306.4	-	-	295.4						
65.6	308.6	-	-	297.6	-	-	286.6	-	-	277.8	-	-	266.8						
72.2	282.2	-	-	271.2	-	-	262.4	-	-	253.5	-	-	244.7						
78.7	253.5	-	-	249.1	-	-	240.3	-	-	233.7	-	-	224.9						
85.3	227.1	-	-	224.9	-	-	222.7	-	-	216.1	-	-	207.2						
88.6	216.6	184.1	-	214.4	-	-	212.7	-	-	208.3	-	-	199.5						
91.9	206.1	175.3	-	203.9	-	-	202.8	-	-	200.6	-	-	191.8						
95.1	191.8*	167.6	-	195.1	163.1	-	194.0	-	-	192.4	-	-	185.2						
98.4	-	159.8	-	186.3	155.4	-	185.2	-	-	184.1	-	-	178.6						
105.0	-	147.2	-	172.0	143.3	-	170.9	141.1	-	169.8	-	-	165.3						
111.5	-	134.5	-	157.6	131.2	-	156.5	129.0	-	155.4	127.9	-	152.1						
114.8	-	129.8	-	147.7*	126.5	-	151.0	124.3	-	149.9	123.3	-	146.9						
121.4	-	120.4	-	-	117.1	-	140.0	114.9	-	138.9	114.1	-	136.4						
124.7	-	115.7	98.3	-	112.4	-	134.5	110.2	-	133.4	109.6	-	131.2						
134.5	-	-	88.2	-	102.0	-	117.9*	99.8	-	121.0	98.3	-	117.9						
137.8	-	-	84.9	-	98.5	80.7	-	96.3	-	116.8	95.0	-	113.5						
144.4	-	-	79.8	-	92.6	75.4	-	90.5	-	110.1	89.1	-	106.9						
147.6	-	-	77.3	-	-	72.8	-	87.6	69.9	106.7	86.1	-	103.6						
150.9	-	-	74.7	-	-	70.3	-	84.7	67.5	100.1*	83.1	-	100.3						
154.2	-	-	-	-	-	68.2	-	82.3	65.3	97.2*	80.7	-	97.6						
160.8	-	-	-	-	-	64.0	-	77.6	61.0	-	76.0	58.9	92.0						
164.0	-	-	-	-	-	61.9	-	-	58.9	-	73.6	56.9	89.3						
167.3	-	-	-	-	-	60.2	-	-	57.2	-	71.7	55.1	86.9						
170.6	-	-	-	-	-	-	-	-	55.4	-	69.7	53.4	81.4*						
173.9	-	-	-	-	-	-	-	-	53.7	-	67.7	51.6	79.1*						
177.2	-	-	-	-	-	-	-	-	52.0	-	65.7	49.8	-						
180.4	-	-	-	-	-	-	-	-	50.6	-	63.9	48.4	-						
187.0	-	-	-	-	-	-	-	-	47.8	-	-	45.5	-						
190.3	-	-	-	-	-	-	-	-	-	-	-	44.1	-						
200.1	-	-	-	-	-	-	-	-	-	-	-	40.4	-						
203.4	-	-	-	-	-	-	-	-	-	-	-	39.2	-						
206.7	-	-	-	-	-	-	-	-	-	-	-	38.4	-						
216.5	-	-	-	-	-	-	-	-	-	-	-	-	-						
226.4	-	-	-	-	-	-	-	-	-	-	-	-	-						

* Main boom angle 85°

Main boom angle 87°, 85°, 75° and 65°, capacities for intermediate boom positions are calculated by the crane control system IC-1

Operation

SW

452,000 lb + 110,200 lb		27.6 ft			32.2 ft/s			360°			ASME B30.5			
157.5 ft														
177.2 ft			196.9 ft				216.5 ft			236.2 ft				
SW_1														
87°/85°			75°		65°		87°/85°		75°		65°			
ft			1,000 lb											
62.3	271.2	-	-	-	-	-	-	-	-	-	-	-		
65.6	257.9	-	-	249.1	-	-	-	-	-	-	-	-		
68.9	246.9	-	-	238.1	-	-	224.9	-	-	-	-	-		
72.2	235.9	-	-	227.1	-	-	220.5	-	-	-	-	-		
75.5	226.5	-	-	218.3	-	-	211.6	-	-	195.1	-	-		
78.7	217.2	-	-	209.4	-	-	202.8	-	-	194.0	-	-		
85.3	200.6	-	-	194.0	-	-	187.4	-	-	180.8	-	-		
91.9	186.3	-	-	179.7	-	-	174.2	-	-	167.6	-	-		
98.4	173.1	-	-	167.6	-	-	162.0	-	-	155.4	-	-		
111.5	152.1	-	-	146.6	-	-	141.1	-	-	135.6	-	-		
124.7	131.2	-	-	129.0	-	-	124.6	-	-	119.0	-	-		
128.0	126.8	101.6	-	124.6	-	-	121.0	-	-	115.9	-	-		
137.8	113.5	91.1	-	111.3	88.6	-	110.2	-	-	106.5	-	-		
144.4	106.8	85.1	-	104.7	82.6	-	103.6	80.2	-	100.8	-	-		
150.9	100.1	79.1	-	98.1	76.5	-	97.0	74.5	-	95.0	-	-		
154.2	97.2	76.7	-	95.3	74.0	-	94.1	71.9	-	92.3	68.3	-		
164.0	88.6	69.2	-	86.9	66.4	-	85.5	64.4	-	84.2	62.4	-		
177.2	79.4	60.6	-	77.2	58.0	-	75.8	56.0	-	74.5	54.0	-		
180.4	77.4	58.9	43.0	75.1	56.2	-	73.9	54.2	-	72.5	52.2	-		
190.3	68.6*	53.6	38.6	69.2	50.9	-	67.9	48.9	-	66.4	47.0	-		
193.6	-	52.1	37.3	67.5	49.4	34.2	66.1	47.4	-	64.6	45.3	-		
203.4	-	47.6	33.5	62.4	44.8	30.4	60.8	42.8	28.2	59.3	40.8	-		
210.0	-	45.1	31.3	56.9*	42.2	28.2	57.9	40.1	26.0	56.2	38.1	-		
216.5	-	42.5	29.1	-	39.7	26.0	54.9	37.7	23.8	53.1	35.5	21.4		
219.8	-	41.4	28.1	-	38.4	25.1	53.7	36.5	22.9	51.7	34.3	20.4		
229.7	-	-	25.4	-	35.3	22.3	47.0*	33.1	20.1	47.6	30.9	17.6		
239.5	-	-	23.0	-	32.4	19.8	-	30.1	17.6	44.0	27.9	15.1		
242.8	-	-	22.3	-	-	19.0	-	29.1	16.8	42.8	26.9	14.3		
246.1	-	-	21.6	-	-	18.3	-	28.3	16.0	39.0*	25.9	13.6		
249.3	-	-	-	-	-	17.6	-	27.4	15.3	37.9*	24.9	12.9		
255.9	-	-	-	-	-	16.3	-	25.8	13.9	-	23.4	11.5		
262.5	-	-	-	-	-	15.0	-	-	12.7	-	21.8	10.1		
265.7	-	-	-	-	-	-	-	-	12.1	-	21.1	9.5		
269.0	-	-	-	-	-	-	-	-	11.5	-	20.3	-		
275.6	-	-	-	-	-	-	-	-	10.4	-	18.7	-		
282.2	-	-	-	-	-	-	-	-	9.3	-	-	-		

* Main boom angle 85°

Main boom angle 87°, 85°, 75° and 65°, capacities for intermediate boom positions are calculated by the crane control system IC-1

Operation

SW

452,000 lb + 110,200 lb		27.6 ft		32.2 ft/s		360°		ASME B30.5									
157.5 ft																	
255.9 ft			275.6 ft			295.3 ft			315.0 ft								
SW_1																	
87°/85°			75°			65°			87°/85°			75°			65°		
ft				1,000 lb													
78.7	166.4	-	-	-	-	-	-	-	-	-	-	-	-	-	-	-	-
82.0	165.9	-	-	142.2	-	-	-	-	-	-	-	-	-	-	-	-	-
85.3	165.3	-	-	141.1	-	-	-	-	-	-	-	-	-	-	-	-	-
88.6	163.7	-	-	140.5	-	-	121.3	-	-	-	-	-	-	-	-	-	-
91.9	162.0	-	-	140.0	-	-	120.2	-	-	104.3	-	-	-	-	-	-	-
98.4	149.9	-	-	138.9	-	-	119.0	-	-	103.4	-	-	-	-	-	-	-
111.5	131.2	-	-	125.7	-	-	116.8	-	-	101.4	-	-	-	-	-	-	-
124.7	114.6	-	-	110.2	-	-	106.0	-	-	99.2	-	-	-	-	-	-	-
137.8	102.3	-	-	97.4	-	-	93.5	-	-	88.8	-	-	-	-	-	-	-
150.9	91.1	-	-	86.4	-	-	82.7	-	-	78.3	-	-	-	-	-	-	-
164.0	81.6	58.4	-	77.2	-	-	73.6	-	-	69.2	-	-	-	-	-	-	-
170.6	77.4	55.1	-	73.1	50.3	-	69.6	-	-	65.3	-	-	-	-	-	-	-
177.2	73.2	51.8	-	69.0	47.2	-	65.5	-	-	61.3	-	-	-	-	-	-	-
180.4	71.2	50.0	-	67.2	45.7	-	63.7	42.1	-	59.6	-	-	-	-	-	-	-
187.0	67.1	46.5	-	63.7	42.7	-	60.3	39.3	-	56.2	34.8	-	-	-	-	-	-
190.3	65.0	45.0	-	61.9	41.2	-	58.6	37.9	-	54.5	33.5	-	-	-	-	-	-
203.4	58.0	38.8	-	55.1	35.5	-	52.5	32.8	-	48.5	28.7	-	-	-	-	-	-
216.5	51.4	33.5	-	48.5	30.2	-	47.0	28.4	-	43.0	24.3	-	-	-	-	-	-
226.4	47.2	30.0	16.3	44.4	26.7	-	42.8	25.0	-	39.3	21.3	-	-	-	-	-	-
229.7	45.9	28.9	15.4	43.0	25.6	-	41.4	23.8	-	38.1	20.3	-	-	-	-	-	-
242.8	40.8	24.9	12.1	37.9	21.6	-	36.4	19.8	-	33.7	16.8	-	-	-	-	-	-
255.9	36.4	21.2	9.3	33.5	17.9	-	32.0	16.3	-	29.8	13.4	-	-	-	-	-	-
269.0	30.2*	18.1	-	29.5	14.8	-	28.0	13.0	-	25.8	10.6	-	-	-	-	-	-
275.6	-	16.6	-	27.9	13.3	-	26.2	11.6	-	24.0	9.3	-	-	-	-	-	-
282.2	-	15.2	-	26.2	11.9	-	24.5	10.1	-	22.3	-	-	-	-	-	-	-
285.4	-	14.6	-	22.9*	11.2	-	23.6	9.5	-	21.4	-	-	-	-	-	-	-
295.3	-	12.8	-	-	9.3	-	21.2	-	-	19.0	-	-	-	-	-	-	-
305.1	-	-	-	-	-	-	16.8*	-	-	16.8	-	-	-	-	-	-	-
308.4	-	-	-	-	-	-	-	-	-	16.1	-	-	-	-	-	-	-
321.5	-	-	-	-	-	-	-	-	-	11.2*	-	-	-	-	-	-	-
324.8	-	-	-	-	-	-	-	-	-	10.6*	-	-	-	-	-	-	-

* Main boom angle 85°

Main boom angle 87°, 85°, 75° and 65°, capacities for intermediate boom positions are calculated by the crane control system IC-1

Operation

SW

452,000 lb + 110,200 lb		27.6 ft		32.2 ft/s		360°		ASME B30.5									
177.2 ft																	
78.7 ft			98.4 ft			118.1 ft			137.8 ft			157.5 ft					
SW_1																	
87°/85°			75°			65°			87°/85°			75°			65°		
ft			1,000 lb														
39.4	476.2	-	-	-	-	-	-	-	-	-	-	-	-	-			
45.9	414.5	-	-	399.0	-	-	-	-	-	-	-	-	-	-			
49.2	390.2	-	-	374.8	-	-	359.4	-	-	-	-	-	-	-			
52.5	368.2	-	-	352.7	-	-	339.5	-	-	328.5	-	-	-	-			
55.8	348.3	-	-	335.1	-	-	321.9	-	-	310.9	-	-	297.6	-			
59.1	328.5	-	-	317.5	-	-	306.4	-	-	295.4	-	-	284.4	-			
65.6	297.6	-	-	286.6	-	-	277.8	-	-	269.0	-	-	257.9	-			
72.2	273.4	-	-	262.4	-	-	253.5	-	-	244.7	-	-	235.9	-			
78.7	251.3	-	-	242.5	-	-	233.7	-	-	224.9	-	-	217.2	-			
85.3	224.9	-	-	222.7	-	-	216.1	-	-	209.4	-	-	200.6	-			
91.9	205.0	-	-	202.8	-	-	200.6	-	-	194.0	-	-	186.3	-			
95.1	190.1*	159.8	-	194.0	-	-	192.4	-	-	187.9	-	-	179.7	-			
98.4	181.9*	153.2	-	185.2	-	-	184.1	-	-	181.9	-	-	173.1	-			
101.7	-	147.2	-	178.0	143.3	-	176.9	-	-	175.0	-	-	167.6	-			
111.5	-	129.0	-	156.5	125.7	-	155.4	123.5	-	154.3	-	-	151.0	-			
118.1	-	119.6	-	140.0*	116.7	-	144.4	114.5	-	143.3	112.4	-	140.5	-			
124.7	-	110.2	-	-	107.8	-	133.4	105.8	-	132.3	104.5	-	130.1	-			
128.0	-	107.4	-	-	103.8	-	129.0	102.3	-	128.1	101.0	-	125.7	97.0			
134.5	-	-	79.4	-	97.1	-	116.6*	95.2	-	119.9	93.9	-	116.8	89.9			
137.8	-	-	76.5	-	93.7	-	112.4*	91.7	-	115.7	90.4	-	112.4	86.4			
147.6	-	-	69.1	-	85.3	64.4	-	83.3	-	105.6	81.6	-	102.7	77.7			
150.9	-	-	66.6	-	-	62.2	-	80.5	-	98.3*	78.7	-	99.4	74.7			
154.2	-	-	64.6	-	-	60.2	-	78.1	-	95.7*	76.3	-	96.7	72.2			
157.5	-	-	62.6	-	-	58.3	-	75.7	55.3	-	74.0	-	93.9	69.7			
164.0	-	-	-	-	-	54.5	-	71.0	51.6	-	69.2	-	88.4	65.0			
167.3	-	-	-	-	-	52.9	-	69.0	49.8	-	67.2	47.8	86.0	63.1			
173.9	-	-	-	-	-	49.8	-	-	46.5	-	63.3	44.6	77.8*	59.1			
177.2	-	-	-	-	-	48.3	-	-	45.0	-	61.3	43.0	-	57.1			
180.4	-	-	-	-	-	-	-	-	43.7	-	59.7	41.6	-	55.4			
187.0	-	-	-	-	-	-	-	-	41.0	-	56.4	38.9	-	52.1			
190.3	-	-	-	-	-	-	-	-	39.7	-	-	37.5	-	50.5			
196.9	-	-	-	-	-	-	-	-	37.7	-	-	35.3	-	47.7			
203.4	-	-	-	-	-	-	-	-	-	-	-	33.1	-	45.0			
216.5	-	-	-	-	-	-	-	-	-	-	-	29.5	-	24.5			
229.7	-	-	-	-	-	-	-	-	-	-	-	-	-	21.4			
232.9	-	-	-	-	-	-	-	-	-	-	-	-	-	20.7			

* Main boom angle 85°

Main boom angle 87°, 85°, 75° and 65°, capacities for intermediate boom positions are calculated by the crane control system IC-1

Operation

SW

452,000 lb + 110,200 lb		27.6 ft			32.2 ft/s			360°			ASME B30.5			
177.2 ft														
177.2 ft			196.9 ft				216.5 ft			236.2 ft				
SW_1														
87°/85°			75°		65°		87°/85°		75°		65°			
ft			1,000 lb											
62.3	260.1	-	-	-	-	-	-	-	-	-	-	-		
65.6	249.1	-	-	240.3	-	-	-	-	-	-	-	-		
72.2	227.1	-	-	220.5	-	-	208.3	-	-	-	-	-		
75.5	218.3	-	-	211.6	-	-	202.3	-	-	181.9	-	-		
78.7	209.4	-	-	202.8	-	-	196.2	-	-	179.7	-	-		
85.3	194.0	-	-	187.4	-	-	180.8	-	-	174.2	-	-		
91.9	179.7	-	-	173.1	-	-	167.6	-	-	162.0	-	-		
98.4	167.6	-	-	162.0	-	-	156.5	-	-	149.9	-	-		
111.5	146.6	-	-	141.1	-	-	136.7	-	-	131.2	-	-		
124.7	130.1	-	-	124.6	-	-	121.3	-	-	115.7	-	-		
134.5	116.8	89.5	-	114.6	-	-	111.2	-	-	106.2	-	-		
137.8	112.4	86.2	-	111.3	-	-	107.8	-	-	103.0	-	-		
144.4	105.8	80.2	-	104.4	77.2	-	102.0	-	-	97.4	-	-		
150.9	99.2	74.3	-	97.4	71.4	-	96.1	68.8	-	91.9	-	-		
160.8	90.8	66.8	-	88.8	64.2	-	87.5	62.0	-	84.8	58.0	-		
164.0	88.0	64.6	-	86.0	61.7	-	84.7	59.7	-	82.5	56.2	-		
177.2	78.5	56.4	-	76.5	53.8	-	75.2	51.8	-	73.9	49.8	-		
190.3	67.5*	49.6	32.2	68.6	47.0	-	67.0	45.0	-	65.7	43.0	-		
193.6	65.7*	48.2	31.0	66.9	45.5	-	65.3	43.4	-	64.0	41.5	-		
203.4	-	43.9	27.6	61.7	41.0	24.5	60.2	39.0	-	58.9	37.0	-		
213.3	-	40.2	24.6	54.2*	37.4	21.3	55.9	35.2	19.2	54.0	33.2	-		
216.5	-	39.0	23.6	-	36.2	20.3	54.5	34.0	18.1	52.5	32.0	-		
223.1	-	36.8	21.8	-	34.0	18.6	51.7	31.9	16.4	49.7	29.8	13.9		
229.7	-	-	20.1	-	31.7	17.0	45.6*	29.8	14.8	47.0	27.6	12.3		
232.9	-	-	19.3	-	30.9	16.2	44.5*	28.8	14.0	45.7	26.6	11.6		
242.8	-	-	17.2	-	28.2	13.9	-	26.0	11.7	42.1	23.6	9.3		
249.3	-	-	15.9	-	-	12.6	-	24.3	10.4	36.8*	21.9	-		
252.6	-	-	15.2	-	-	11.9	-	23.5	9.7	-	21.1	-		
255.9	-	-	-	-	-	11.2	-	22.7	9.0	-	20.3	-		
262.5	-	-	-	-	-	10.3	-	21.2	-	-	18.7	-		
269.0	-	-	-	-	-	9.3	-	-	-	-	17.2	-		
282.2	-	-	-	-	-	-	-	-	-	-	14.8	-		

* Main boom angle 85°

Main boom angle 87°, 85°, 75° and 65°, capacities for intermediate boom positions are calculated by the crane control system IC-1

Operation

SW

452,000 lb + 110,200 lb		27.6 ft		32.2 ft/s		360°		ASME B30.5									
177.2 ft																	
255.9 ft			275.6 ft			295.3 ft			315.0 ft								
SW_1																	
87°/85°			75°			65°			87°/85°			75°			65°		
ft				1,000 lb													
78.7	153.2	-	-	-	-	-	-	-	-	-	-	-	-	-	-	-	-
85.3	152.1	-	-	132.3	-	-	-	-	-	-	-	-	-	-	-	-	-
88.6	151.0	-	-	131.7	-	-	113.5	-	-	-	-	-	-	-	-	-	-
91.9	149.9	-	-	131.2	-	-	112.4	-	-	97.7	-	-	-	-	-	-	-
98.4	144.4	-	-	130.1	-	-	111.3	-	-	96.8	-	-	-	-	-	-	-
111.5	126.8	-	-	121.3	-	-	110.0	-	-	95.0	-	-	-	-	-	-	-
124.7	111.3	-	-	106.3	-	-	102.3	-	-	93.0	-	-	-	-	-	-	-
137.8	98.8	-	-	93.9	-	-	89.9	-	-	85.3	-	-	-	-	-	-	-
150.9	88.0	-	-	83.3	-	-	79.6	-	-	75.2	-	-	-	-	-	-	-
164.0	78.7	-	-	74.3	-	-	70.8	-	-	66.4	-	-	-	-	-	-	-
167.3	76.7	50.7	-	72.3	-	-	68.8	-	-	64.5	-	-	-	-	-	-	-
177.2	70.8	46.1	-	66.4	41.4	-	63.1	-	-	58.9	-	-	-	-	-	-	-
183.7	67.2	43.2	-	62.8	38.7	-	59.6	35.1	-	55.4	-	-	-	-	-	-	-
190.3	63.7	40.3	-	59.5	35.9	-	56.2	32.4	-	52.0	-	-	-	-	-	-	-
193.6	62.2	39.0	-	58.0	34.7	-	54.7	31.3	-	50.5	26.9	-	-	-	-	-	-
203.4	57.3	35.1	-	53.4	31.1	-	50.3	27.8	-	46.1	23.6	-	-	-	-	-	-
216.5	50.7	30.0	-	47.8	26.7	-	44.8	23.6	-	41.0	19.4	-	-	-	-	-	-
229.7	45.2	25.6	-	42.3	22.3	-	40.1	19.8	-	36.2	15.7	-	-	-	-	-	-
242.8	40.1	21.6	-	37.3	18.3	-	35.7	16.5	-	32.0	12.3	-	-	-	-	-	-
255.9	35.9	18.3	-	32.8	15.0	-	31.3	13.2	-	28.0	9.5	-	-	-	-	-	-
269.0	29.1*	15.2	-	28.9	11.9	-	27.3	10.1	-	24.7	-	-	-	-	-	-	-
272.3	-	14.6	-	28.1	11.2	-	26.5	9.5	-	23.9	-	-	-	-	-	-	-
282.2	-	12.6	-	25.6	9.0	-	23.8	-	-	21.4	-	-	-	-	-	-	-
288.7	-	11.4	-	21.4*	-	-	22.3	-	-	20.0	-	-	-	-	-	-	-
295.3	-	10.1	-	-	-	-	20.7	-	-	18.5	-	-	-	-	-	-	-
298.6	-	9.5	-	-	-	-	20.0	-	-	17.8	-	-	-	-	-	-	-
308.4	-	-	-	-	-	-	15.4*	-	-	15.7	-	-	-	-	-	-	-
321.5	-	-	-	-	-	-	-	-	-	13.0	-	-	-	-	-	-	-
324.8	-	-	-	-	-	-	-	-	-	9.9*	-	-	-	-	-	-	-

* Main boom angle 85°

Main boom angle 87°, 85°, 75° and 65°, capacities for intermediate boom positions are calculated by the crane control system IC-1

Operation

SW

452,000 lb + 110,200 lb		27.6 ft		32.2 ft/s		360°		ASME B30.5									
196.9 ft																	
78.7 ft			98.4 ft			118.1 ft			137.8 ft			157.5 ft					
SW_1																	
87°/85°			75°			65°			87°/85°			75°			65°		
ft			1,000 lb														
42.7	423.3	-	-	-	-	-	-	-	-	-	-	-	-	-			
45.9	396.8	-	-	381.4	-	-	-	-	-	-	-	-	-	-			
49.2	372.6	-	-	359.4	-	-	343.9	-	-	-	-	-	-	-			
52.5	352.7	-	-	339.5	-	-	326.3	-	-	-	-	-	-	-			
55.8	332.9	-	-	321.9	-	-	308.6	-	-	299.8	-	-	-	-			
59.1	317.5	-	-	304.2	-	-	293.2	-	-	284.4	-	-	271.2	-			
65.6	286.6	-	-	277.8	-	-	266.8	-	-	257.9	-	-	246.9	-			
72.2	262.4	-	-	253.5	-	-	244.7	-	-	235.9	-	-	227.1	-			
78.7	242.5	-	-	233.7	-	-	224.9	-	-	218.3	-	-	209.4	-			
85.3	224.9	-	-	217.2	-	-	208.3	-	-	201.7	-	-	194.0	-			
91.9	203.9	-	-	200.6	-	-	194.0	-	-	188.5	-	-	179.7	-			
98.4	178.6*	146.6	-	183.0	-	-	180.8	-	-	175.3	-	-	167.6	-			
108.3	-	128.4	-	162.3	124.6	-	160.1	-	-	158.7	-	-	152.7	-			
111.5	-	122.4	-	155.4	119.0	-	153.2	-	-	153.2	-	-	147.7	-			
114.8	-	118.1	-	143.3*	114.8	-	148.0	112.4	-	147.7	-	-	143.0	-			
118.1	-	113.8	-	137.8*	110.6	-	142.7	108.4	-	142.2	-	-	138.3	-			
124.7	-	105.6	-	-	102.1	-	132.3	100.3	-	131.2	98.8	-	129.0	-			
134.5	-	95.0	-	-	91.8	-	114.4*	89.7	-	118.8	88.2	-	115.7	83.8			
137.8	-	-	-	-	88.4	-	110.2*	86.2	-	114.6	84.7	-	111.3	80.5			
144.4	-	-	62.2	-	82.9	-	-	80.6	-	108.0	78.9	-	104.8	74.5			
150.9	-	-	58.0	-	77.4	-	-	75.0	-	101.4	73.2	-	98.3	69.2			
154.2	-	-	56.2	-	75.2	51.4	-	72.7	-	94.0*	70.8	-	95.6	66.9			
157.5	-	-	54.3	-	-	49.6	-	70.4	-	91.3*	68.3	-	92.8	64.6			
164.0	-	-	50.7	-	-	46.1	-	65.9	-	-	63.9	-	87.3	60.0			
167.3	-	-	49.2	-	-	44.6	-	63.9	41.9	-	62.1	-	85.0	58.0			
170.6	-	-	-	-	-	43.2	-	61.9	40.4	-	60.2	-	82.7	56.1			
177.2	-	-	-	-	-	40.3	-	-	37.5	-	56.4	35.5	74.3*	52.2			
187.0	-	-	-	-	-	37.0	-	-	33.8	-	51.8	31.7	-	47.5			
190.3	-	-	-	-	-	-	-	-	32.6	-	50.3	30.4	-	45.9	25.8		
203.4	-	-	-	-	-	-	-	-	28.7	-	-	26.2	-	40.6	21.6		
210.0	-	-	-	-	-	-	-	-	-	-	-	24.6	-	38.4	19.8		
216.5	-	-	-	-	-	-	-	-	-	-	-	22.9	-	-	18.1		
223.1	-	-	-	-	-	-	-	-	-	-	-	21.6	-	-	16.7		
229.7	-	-	-	-	-	-	-	-	-	-	-	-	-	-	15.2		
242.8	-	-	-	-	-	-	-	-	-	-	-	-	-	-	13.0		

* Main boom angle 85°

Main boom angle 87°, 85°, 75° and 65°, capacities for intermediate boom positions are calculated by the crane control system IC-1

Operation

SW

452,000 lb + 110,200 lb		27.6 ft			32.2 ft/s			360°		ASME B30.5			
196.9 ft													
177.2 ft			196.9 ft				216.5 ft			236.2 ft			
SW_1													
87°/85°			75°		65°		87°/85°		75°		65°		
ft			1,000 lb										
62.3	251.3	-	-	-	-	-	-	-	-	-	-	-	
65.6	240.3	-	-	222.7	-	-	-	-	-	-	-	-	
72.2	219.4	-	-	211.6	-	-	192.9	-	-	-	-	-	
75.5	210.5	-	-	203.4	-	-	190.7	-	-	168.7	-	-	
78.7	201.7	-	-	195.1	-	-	188.5	-	-	167.6	-	-	
85.3	187.4	-	-	180.8	-	-	174.2	-	-	165.3	-	-	
91.9	174.2	-	-	167.6	-	-	162.0	-	-	155.4	-	-	
98.4	162.0	-	-	156.5	-	-	151.0	-	-	144.4	-	-	
111.5	142.2	-	-	136.7	-	-	132.3	-	-	126.8	-	-	
124.7	125.7	-	-	121.3	-	-	116.8	-	-	111.3	-	-	
137.8	111.3	-	-	108.2	-	-	104.3	-	-	99.2	-	-	
141.1	108.1	76.9	-	105.3	-	-	101.6	-	-	96.5	-	-	
150.9	98.3	69.0	-	96.6	65.7	-	93.5	-	-	88.6	-	-	
157.5	92.7	64.3	-	90.8	61.3	-	88.6	58.0	-	84.1	-	-	
164.0	87.1	59.5	-	85.1	56.9	-	84.0	54.5	-	79.6	-	-	
167.3	84.8	57.6	-	82.7	55.0	-	81.6	52.6	-	77.6	48.1	-	
177.2	77.8	51.8	-	75.8	49.2	-	74.5	47.2	-	71.7	43.7	-	
190.3	66.1*	45.4	-	67.7	42.5	-	66.4	40.6	-	64.8	38.4	-	
193.6	64.4*	44.0	-	66.0	41.2	-	64.7	39.2	-	63.2	37.0	-	
200.1	-	41.2	22.0	62.7	38.4	-	61.2	36.4	-	59.9	34.4	-	
203.4	-	39.9	20.9	61.1	37.0	-	59.5	35.1	-	58.2	33.1	-	
210.0	-	37.5	19.2	54.4*	34.6	15.9	56.5	32.6	-	55.0	30.6	-	
213.3	-	36.3	18.3	52.9*	33.4	15.0	55.1	31.4	-	53.4	29.4	-	
216.5	-	35.1	17.4	-	32.2	14.1	53.6	30.2	-	51.8	28.2	-	
229.7	-	31.1	14.1	-	28.0	11.0	44.5*	26.0	-	46.3	24.0	-	
232.9	-	-	13.4	-	27.1	10.4	43.2*	25.1	-	45.1	23.1	-	
239.5	-	-	12.1	-	25.4	9.0	-	23.4	-	42.7	21.2	-	
242.8	-	-	11.5	-	24.7	-	-	22.5	-	41.4	20.3	-	
249.3	-	-	10.4	-	23.1	-	-	20.9	-	35.7*	18.6	-	
252.6	-	-	9.8	-	-	-	-	20.2	-	34.8*	17.8	-	
255.9	-	-	9.3	-	-	-	-	19.4	-	-	17.0	-	
265.7	-	-	-	-	-	-	-	17.2	-	-	14.8	-	
269.0	-	-	-	-	-	-	-	-	-	-	14.1	-	
282.2	-	-	-	-	-	-	-	-	-	-	11.7	-	
285.4	-	-	-	-	-	-	-	-	-	-	11.2	-	

* Main boom angle 85°

Main boom angle 87°, 85°, 75° and 65°, capacities for intermediate boom positions are calculated by the crane control system IC-1

Operation

SW

452,000 lb + 110,200 lb		27.6 ft			32.2 ft/s			360°		ASME B30.5			
196.9 ft													
255.9 ft			275.6 ft				295.3 ft			315.0 ft			
SW_1													
87°/85°			75°		65°		87°/85°		75°		65°		
ft			1,000 lb										
82.0	142.2	-	-	-	-	-	-	-	-	-	-	-	
85.3	141.1	-	-	123.5	-	-	-	-	-	-	-	-	
88.6	140.5	-	-	122.9	-	-	106.3	-	-	-	-	-	
91.9	140.0	-	-	122.4	-	-	105.6	-	-	-	-	-	
95.1	138.9	-	-	121.8	-	-	105.2	-	-	90.8	-	-	
98.4	137.8	-	-	121.3	-	-	104.7	-	-	90.4	-	-	
111.5	121.3	-	-	115.7	-	-	102.5	-	-	88.8	-	-	
124.7	107.4	-	-	102.3	-	-	98.1	-	-	86.9	-	-	
137.8	95.0	-	-	90.2	-	-	86.4	-	-	81.6	-	-	
150.9	84.7	-	-	80.0	-	-	76.3	-	-	71.9	-	-	
164.0	75.6	-	-	71.2	-	-	67.7	-	-	63.5	-	-	
173.9	69.8	41.2	-	65.6	-	-	62.0	-	-	57.9	-	-	
177.2	67.9	39.9	-	63.7	-	-	60.2	-	-	56.0	-	-	
183.7	64.5	37.3	-	60.3	32.6	-	56.9	-	-	52.8	-	-	
190.3	61.1	34.6	-	56.9	30.2	-	53.6	26.7	-	49.6	-	-	
200.1	56.6	31.3	-	52.6	26.9	-	49.3	23.4	-	45.3	19.0	-	
203.4	55.1	30.2	-	51.1	25.8	-	47.8	22.3	-	43.9	18.1	-	
216.5	49.8	26.0	-	45.9	21.8	-	42.5	18.5	-	38.8	14.3	-	
229.7	44.5	22.0	-	41.0	18.3	-	37.9	15.0	-	34.2	10.8	-	
236.2	42.0	20.2	-	38.8	16.5	-	35.8	13.4	-	32.1	9.3	-	
242.8	39.5	18.3	-	36.6	14.8	-	33.7	11.9	-	30.0	-	-	
255.9	35.3	15.0	-	32.2	11.7	-	30.0	9.0	-	26.2	-	-	
265.7	32.4	12.8	-	29.4	9.5	-	27.5	-	-	23.8	-	-	
269.0	28.2*	12.1	-	28.4	-	-	26.7	-	-	22.9	-	-	
272.3	27.3*	11.5	-	27.6	-	-	25.9	-	-	22.2	-	-	
282.2	-	9.5	-	24.9	-	-	23.4	-	-	19.8	-	-	
285.4	-	8.8	-	21.1*	-	-	22.6	-	-	19.1	-	-	
288.7	-	-	-	20.3*	-	-	21.8	-	-	18.4	-	-	
295.3	-	-	-	-	-	-	20.3	-	-	17.0	-	-	
308.4	-	-	-	-	-	-	14.3*	-	-	14.3	-	-	
321.5	-	-	-	-	-	-	-	-	-	12.1	-	-	

* Main boom angle 85°

Main boom angle 87°, 85°, 75° and 65°, capacities for intermediate boom positions are calculated by the crane control system IC-1

Operation

SW

452,000 lb + 110,200 lb		27.6 ft			32.2 ft/s			360°			ASME B30.5								
216.5 ft																			
78.7 ft				98.4 ft				118.1 ft				137.8 ft				157.5 ft			
SW_1																			
87°/85° 75° 65°				87°/85° 75° 65°				87°/85° 75° 65°				87°/85° 75° 65°							
ft		1,000 lb																	
42.7	405.7	-	-	-	-	-	-	-	-	-	-	-	-						
45.9	379.2	-	-	-	-	-	-	-	-	-	-	-	-						
49.2	357.1	-	-	343.9	-	-	-	-	-	-	-	-	-						
52.5	339.5	-	-	326.3	-	-	313.1	-	-	-	-	-	-						
55.8	319.7	-	-	308.6	-	-	297.6	-	-	286.6	-	-	-						
59.1	304.2	-	-	293.2	-	-	282.2	-	-	273.4	-	-	262.4						
65.6	277.8	-	-	266.8	-	-	257.9	-	-	249.1	-	-	238.1						
72.2	253.5	-	-	244.7	-	-	235.9	-	-	229.3	-	-	219.4						
78.7	233.7	-	-	224.9	-	-	217.2	-	-	210.5	-	-	201.7						
85.3	218.3	-	-	209.4	-	-	201.7	-	-	195.1	-	-	187.4						
91.9	201.7	-	-	195.1	-	-	187.4	-	-	181.9	-	-	174.2						
98.4	176.4*	-	-	181.9	-	-	175.3	-	-	169.8	-	-	162.0						
101.7	168.7*	-	-	174.7	-	-	169.5	-	-	164.8	-	-	157.1						
105.0	-	127.9	-	167.6	-	-	163.7	-	-	159.8	-	-	152.1						
111.5	-	116.8	-	153.2	-	-	152.1	-	-	149.9	-	-	142.2						
114.8	-	112.7	-	141.5*	109.1	-	146.9	-	-	145.0	-	-	138.3						
121.4	-	104.4	-	131.2*	100.6	-	136.4	98.3	-	135.0	-	-	130.6						
124.7	-	100.3	-	-	96.3	-	131.2	94.4	-	130.1	-	-	126.8						
131.2	-	93.6	-	-	89.5	-	122.4	87.5	-	121.8	85.5	-	118.5						
137.8	-	86.9	-	-	82.7	-	109.1*	80.7	-	113.5	79.1	-	110.2	75.0					
141.1	-	-	-	-	80.0	-	105.6*	77.8	-	110.2	76.1	-	107.0	72.2					
150.9	-	-	-	-	72.1	-	-	69.7	-	100.3	68.1	-	97.2	63.9					
154.2	-	-	48.1	-	69.7	-	-	67.5	-	92.3*	65.9	-	94.5	61.7					
157.5	-	-	46.4	-	67.7	-	-	65.3	-	89.5*	63.7	-	91.7	59.5					
164.0	-	-	43.2	-	-	38.6	-	60.8	-	-	59.3	-	86.2	55.1					
173.9	-	-	39.0	-	-	34.6	-	55.7	-	-	53.8	-	74.9*	49.7					
177.2	-	-	-	-	-	33.3	-	54.0	30.6	-	52.0	-	72.8*	47.8					
187.0	-	-	-	-	-	29.9	-	-	27.2	-	47.4	25.1	-	43.1					
190.3	-	-	-	-	-	28.9	-	-	26.0	-	45.9	24.0	-	41.7					
193.6	-	-	-	-	-	28.0	-	-	25.1	-	44.6	23.0	-	40.4					
196.9	-	-	-	-	-	-	-	-	24.1	-	43.4	22.0	-	39.1	17.4				
203.4	-	-	-	-	-	-	-	-	22.3	-	-	20.1	-	36.6	15.4				
213.3	-	-	-	-	-	-	-	-	20.1	-	-	17.6	-	33.5	13.1				
216.5	-	-	-	-	-	-	-	-	-	-	-	17.0	-	32.4	12.3				
229.7	-	-	-	-	-	-	-	-	-	-	-	14.6	-	-	9.5				
232.9	-	-	-	-	-	-	-	-	-	-	-	14.1	-	-	9.0				

* Main boom angle 85°

Main boom angle 87°, 85°, 75° and 65°, capacities for intermediate boom positions are calculated by the crane control system IC-1

Operation

SW

452,000 lb + 110,200 lb		27.6 ft		32.2 ft/s		360°		ASME B30.5											
216.5 ft																			
177.2 ft			196.9 ft			216.5 ft			236.2 ft										
SW_1																			
87°/85°			75°			65°			87°/85°			75°			65°				
ft				1,000 lb															
65.6	224.9	-	-	-	-	-	-	-	-	-	-	-	-	-	-	-	-	-	-
68.9	218.3	-	-	198.4	-	-	-	-	-	-	-	-	-	-	-	-	-	-	-
72.2	211.6	-	-	196.2	-	-	173.1	-	-	-	-	-	-	-	-	-	-	-	-
78.7	195.1	-	-	188.5	-	-	169.8	-	-	147.7	-	-	-	-	-	-	-	-	-
85.3	180.8	-	-	174.2	-	-	167.6	-	-	145.5	-	-	-	-	-	-	-	-	-
91.9	167.6	-	-	162.0	-	-	156.5	-	-	143.3	-	-	-	-	-	-	-	-	-
98.4	156.5	-	-	151.0	-	-	145.5	-	-	140.0	-	-	-	-	-	-	-	-	-
111.5	137.8	-	-	132.3	-	-	127.9	-	-	122.4	-	-	-	-	-	-	-	-	-
124.7	122.4	-	-	116.8	-	-	112.4	-	-	107.8	-	-	-	-	-	-	-	-	-
137.8	109.6	-	-	104.7	-	-	100.8	-	-	95.7	-	-	-	-	-	-	-	-	-
147.6	100.5	65.9	-	96.6	-	-	92.6	-	-	88.1	-	-	-	-	-	-	-	-	-
150.9	97.4	63.9	-	93.9	-	-	90.2	-	-	85.5	-	-	-	-	-	-	-	-	-
157.5	91.8	59.5	-	89.3	55.6	-	85.6	-	-	81.1	-	-	-	-	-	-	-	-	-
164.0	86.2	55.1	-	84.4	52.2	-	81.1	48.5	-	76.7	-	-	-	-	-	-	-	-	-
173.9	79.1	49.5	-	77.3	46.6	-	75.3	44.2	-	70.9	39.5	-	-	-	-	-	-	-	-
177.2	76.9	47.6	-	75.0	44.8	-	73.4	42.8	-	69.0	38.1	-	-	-	-	-	-	-	-
190.3	69.2	41.2	-	67.0	38.6	-	65.7	36.6	-	62.4	33.1	-	-	-	-	-	-	-	-
196.9	61.5*	38.6	-	63.6	35.9	-	62.3	34.0	-	59.3	30.9	-	-	-	-	-	-	-	-
203.4	-	35.9	-	60.2	33.3	-	58.9	31.3	-	56.4	28.9	-	-	-	-	-	-	-	-
210.0	-	33.7	13.2	53.1*	31.0	-	55.8	29.0	-	53.8	26.8	-	-	-	-	-	-	-	-
216.5	-	31.5	11.7	50.3*	28.7	-	52.7	26.7	-	51.1	24.7	-	-	-	-	-	-	-	-
226.4	-	28.5	9.5	-	25.7	-	48.7	23.7	-	46.8	21.6	-	-	-	-	-	-	-	-
229.7	-	27.6	-	-	24.7	-	43.2*	22.7	-	45.4	20.5	-	-	-	-	-	-	-	-
232.9	-	26.9	-	-	23.9	-	42.1*	21.8	-	44.3	19.6	-	-	-	-	-	-	-	-
236.2	-	-	-	-	23.0	-	41.0*	20.9	-	43.1	18.7	-	-	-	-	-	-	-	-
242.8	-	-	-	-	21.4	-	-	19.2	-	40.8	17.0	-	-	-	-	-	-	-	-
252.6	-	-	-	-	19.2	-	-	16.9	-	33.7*	14.7	-	-	-	-	-	-	-	-
255.9	-	-	-	-	-	-	-	16.1	-	-	13.9	-	-	-	-	-	-	-	-
269.0	-	-	-	-	-	-	-	13.7	-	-	11.2	-	-	-	-	-	-	-	-
272.3	-	-	-	-	-	-	-	13.0	-	-	10.6	-	-	-	-	-	-	-	-
282.2	-	-	-	-	-	-	-	-	-	-	8.8	-	-	-	-	-	-	-	-

* Main boom angle 85°

Main boom angle 87°, 85°, 75° and 65°, capacities for intermediate boom positions are calculated by the crane control system IC-1

Operation

SW

452,000 lb + 110,200 lb		27.6 ft		32.2 ft/s		360°		ASME B30.5			
216.5 ft											
255.9 ft		275.6 ft			295.3 ft			315.0 ft			
SW_1											
87°/85°		75°		65°		87°/85°		75°		65°	
ft				1,000 lb							
82.0	127.9	-	-	-	-	-	-	-	-	-	-
85.3	126.8	-	-	110.2	-	-	-	-	-	-	-
91.9	125.7	-	-	110.0	-	-	95.0	-	-	-	-
95.1	124.6	-	-	109.3	-	-	94.5	-	-	81.4	-
98.4	123.5	-	-	108.7	-	-	93.9	-	-	80.9	-
111.5	116.8	-	-	106.0	-	-	91.9	-	-	79.4	-
124.7	103.4	-	-	98.3	-	-	89.3	-	-	77.4	-
137.8	91.5	-	-	86.9	-	-	82.9	-	-	75.4	-
150.9	81.6	-	-	76.9	-	-	73.2	-	-	68.8	-
164.0	73.0	-	-	68.3	-	-	65.0	-	-	60.6	-
177.2	65.5	-	-	61.1	-	-	57.5	-	-	53.4	-
180.4	63.7	33.1	-	59.5	-	-	55.9	-	-	51.8	-
190.3	58.6	29.5	-	54.7	24.9	-	51.1	-	-	47.2	-
196.9	55.8	27.3	-	51.7	22.8	-	48.4	19.4	-	44.4	-
203.4	52.9	25.1	-	48.7	20.7	-	45.6	17.4	-	41.7	-
206.7	51.6	24.2	-	47.5	19.8	-	44.3	16.5	-	40.4	12.1
216.5	47.8	21.4	-	43.7	17.2	-	40.6	13.9	-	36.6	9.5
229.7	43.2	18.1	-	39.2	13.9	-	36.2	10.6	-	32.2	-
236.2	41.0	16.5	-	37.1	12.3	-	34.1	9.0	-	30.2	-
242.8	38.8	15.0	-	35.1	10.8	-	32.0	-	-	28.2	-
249.3	36.7	13.4	-	33.2	9.5	-	30.1	-	-	26.2	-
255.9	34.6	11.9	-	31.3	-	-	28.2	-	-	24.5	-
269.0	27.1*	9.3	-	27.8	-	-	24.9	-	-	21.2	-
272.3	26.2*	-	-	27.0	-	-	24.2	-	-	20.4	-
282.2	-	-	-	24.5	-	-	22.0	-	-	18.3	-
292.0	-	-	-	18.5*	-	-	19.9	-	-	16.1	-
295.3	-	-	-	-	-	-	19.2	-	-	15.4	-
308.4	-	-	-	-	-	-	13.2*	-	-	13.0	-
311.7	-	-	-	-	-	-	12.8*	-	-	12.5	-
321.5	-	-	-	-	-	-	-	-	-	10.8	-

* Main boom angle 85°

Main boom angle 87°, 85°, 75° and 65°, capacities for intermediate boom positions are calculated by the crane control system IC-1

Operation

SW

452,000 lb + 110,200 lb		27.6 ft		32.2 ft/s		360°		ASME B30.5	
236.2 ft									
SW_1									
ft									
1,000 lb									
59.1	262.4	-	-	-	-	-	-	-	-
62.3	251.3	-	-	231.5	-	-	-	-	-
65.6	240.3	-	-	229.3	-	-	-	-	-
72.2	220.5	-	-	210.5	-	-	-	-	-
78.7	202.8	-	-	194.0	-	-	-	-	-
85.3	188.5	-	-	179.7	-	-	-	-	-
91.9	175.3	-	-	167.6	-	-	-	-	-
98.4	164.2	-	-	156.5	-	-	-	-	-
111.5	144.4	-	-	137.8	-	-	-	-	-
124.7	129.0	-	-	122.4	-	-	-	-	-
137.8	112.4	72.5	-	109.8	-	-	-	-	-
144.4	105.7	67.2	-	103.0	62.8	-	-	-	-
150.9	99.0	61.9	-	96.1	58.0	-	-	-	-
160.8	85.3*	55.7	-	87.9	51.5	-	-	-	-
164.0	-	53.6	-	85.1	49.4	-	-	-	-
177.2	-	46.5	-	71.0*	42.5	-	-	-	-
180.4	-	45.1	-	69.2*	41.1	-	-	-	-
190.3	-	40.8	-	-	36.6	-	-	-	-
200.1	-	37.5	13.6	-	33.0	-	-	-	-
203.4	-	-	12.8	-	31.7	-	-	-	-
216.5	-	-	9.9	-	27.8	-	-	-	-
219.8	-	-	9.3	-	26.9	-	-	-	-

236.2 ft									
SW_1									
ft									
1,000 lb									
65.6	205.0	-	-	-	-	-	-	-	-
68.9	202.8	-	-	179.7	-	-	-	-	-
72.2	200.6	-	-	178.6	-	-	-	-	-
75.5	194.0	-	-	176.9	-	-	153.2	-	-
78.7	187.4	-	-	175.3	-	-	152.1	-	-
85.3	174.2	-	-	167.6	-	-	149.9	-	-
91.9	162.0	-	-	155.4	-	-	146.6	-	-
98.4	151.0	-	-	145.5	-	-	140.0	-	-
111.5	132.3	-	-	126.8	-	-	122.4	-	-
124.7	117.9	-	-	112.4	-	-	108.7	-	-
137.8	105.6	-	-	100.8	-	-	96.8	-	-
150.9	95.2	-	-	90.6	-	-	86.9	-	-
154.2	92.8	54.7	-	88.4	-	-	84.7	-	-
160.8	87.8	51.1	-	84.0	46.7	-	80.2	-	-
170.6	80.7	46.0	-	77.9	42.4	-	74.3	38.8	-
177.2	76.1	42.5	-	74.1	39.7	-	70.5	36.4	-
190.3	68.3	36.6	-	66.1	33.7	-	63.9	31.7	-
196.9	60.2*	34.1	-	62.8	31.2	-	61.0	29.2	-
203.4	-	31.5	-	59.5	28.7	-	58.0	26.7	-
216.5	-	27.1	-	48.7*	24.3	-	51.8	22.3	-
229.7	-	23.6	-	-	20.5	-	46.5	18.5	-
236.2	-	22.0	-	-	19.0	-	39.5*	17.0	-
239.5	-	21.2	-	-	18.2	-	-	16.2	-
242.8	-	-	-	-	17.4	-	-	15.4	-
255.9	-	-	-	-	14.8	-	-	12.6	-
259.2	-	-	-	-	14.1	-	-	12.0	-
269.0	-	-	-	-	-	-	-	10.1	-
275.6	-	-	-	-	-	-	-	9.0	-

For explanations see page 148

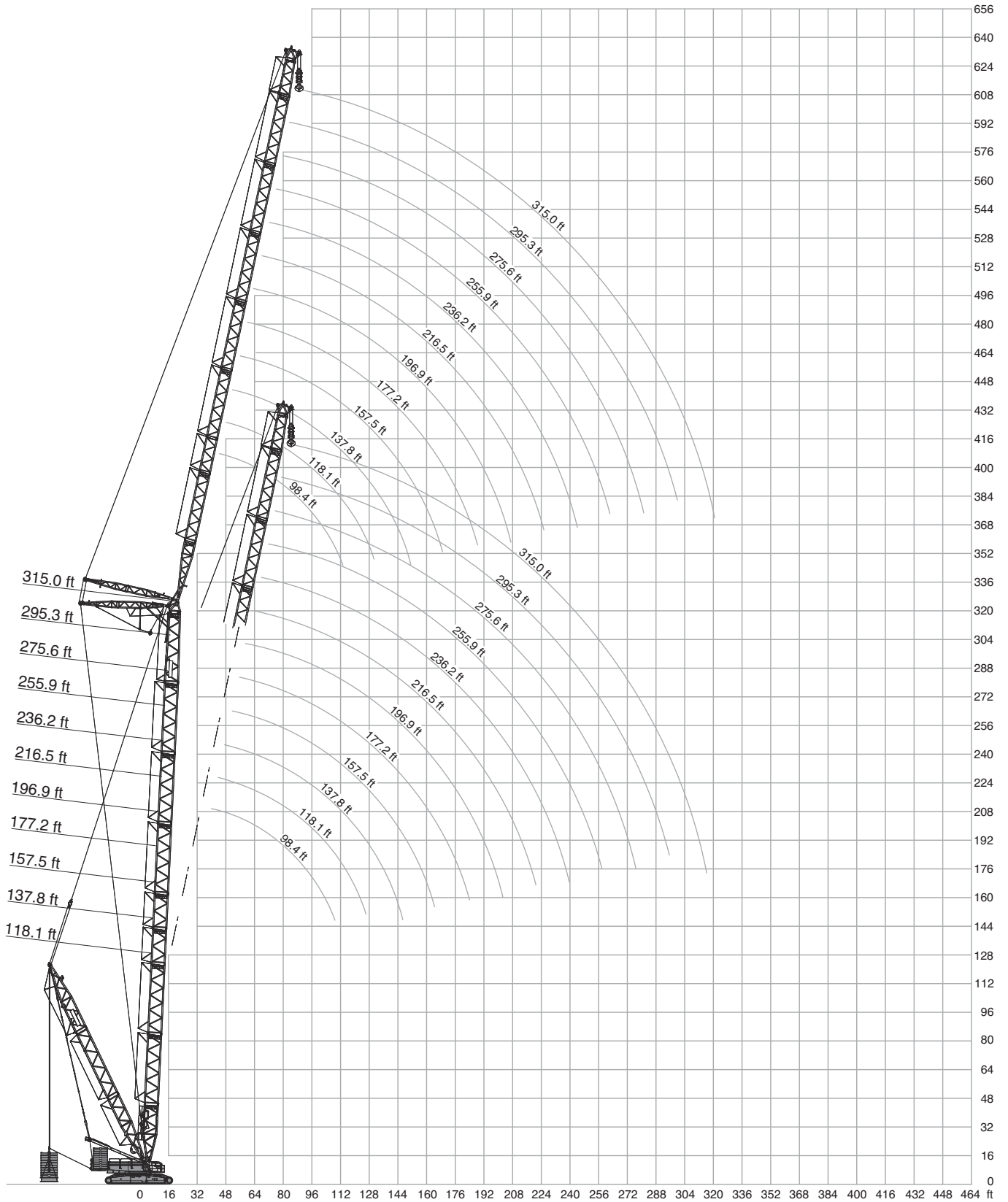

Operation

SWSL, SFSL

363,800 lb + 110,200 lb 36.1-62.3 ft						27.6 ft 32.2 ft/s 360° ASME B30.5					
118.1 ft + 78.7 ft						118.1 ft + 196.9 ft					
SWSL_1 SFSL_1						SWSL_1 SFSL_1					
0 lb 0 lb -716,600 lb						0 lb 0 lb -716,600 lb					
87°/85° 87°/85° 75° 65° 55° 15°						87°/85° 87°/85° 75° 65° 55° 15°					
ft	1,000 lb					ft	1,000 lb				
78.7	-	-	765.0	-	-	128.0	-	-	306.4	-	-
82.0	-	-	740.8	-	-	137.8	-	-	306.4	-	-
85.3	-	-	714.3	-	-	141.1	-	-	306.4	-	313.1
91.9	-	-	663.6	-	-	150.9	-	-	306.4	-	307.8
98.4	-	-	617.3	-	-	164.0	-	-	288.8	-	299.8
108.3	-	-	524.7	546.7	-	173.9	-	-	264.0	264.6	293.2
111.5	-	-	493.8	529.1	-	177.2	-	-	255.7	264.6	291.0
114.8	-	-	451.9	513.1	-	190.3	-	-	224.9	264.6	266.0
124.7	-	-	-	465.2	-	203.4	-	-	198.4	242.5	241.0
134.5	-	-	-	427.7	-	216.5	-	-	174.2	218.3	216.1
137.8	-	-	-	-	381.4	219.8	-	-	167.6	212.5	203.9
150.9	-	-	-	-	343.9	226.4	-	-	154.3	200.9	197.3
164.0	-	-	-	-	-	229.7	-	-	-	195.1	192.9
177.2	-	-	-	-	-	242.8	-	-	-	170.9	179.7
187.0	-	-	-	-	-	246.1	-	-	-	164.2	176.9
						255.9	-	-	-	168.7	152.1
						265.7	-	-	-	160.9	138.1
						269.0	-	-	-	-	133.4
						282.2	-	-	-	-	115.8
						295.3	-	-	-	-	98.3
						298.6	-	-	-	-	93.7

118.1 ft + 118.1 ft					
ft	1,000 lb				
95.1	-	-	632.7	-	-
98.4	-	-	610.7	-	-
101.7	-	-	591.9	-	590.8
111.5	-	-	535.7	-	536.6
124.7	-	-	445.3	-	469.6
131.2	-	-	405.7	434.3	438.7
137.8	-	-	366.0	410.1	407.9
150.9	-	-	295.4	368.2	357.9
164.0	-	-	-	335.1	306.4
170.6	-	-	-	310.9	291.7
177.2	-	-	-	-	280.0
190.3	-	-	-	-	255.7
203.4	-	-	-	-	202.5
216.5	-	-	-	-	170.9
223.1	-	-	-	-	155.4

118.1 ft + 157.5 ft					
ft	1,000 lb				
108.3	-	-	445.3	-	-
111.5	-	-	445.3	-	-
121.4	-	-	445.3	-	454.2
124.7	-	-	445.3	-	447.1
137.8	-	-	383.6	-	418.9
150.9	-	-	330.7	-	374.8
154.2	-	-	320.2	357.1	363.8
164.0	-	-	288.8	332.9	332.2
177.2	-	-	246.9	302.0	291.0
190.3	-	-	208.3	275.6	258.7
193.6	-	-	-	266.2	246.9
203.4	-	-	-	238.1	231.5
210.0	-	-	-	219.4	223.8
216.5	-	-	-	-	216.1
226.4	-	-	-	-	203.9
229.7	-	-	-	-	183.0
242.8	-	-	-	-	176.7
255.9	-	-	-	-	152.9
262.5	-	-	-	-	130.1
					117.9

118.1 ft + 236.2 ft					
ft	1,000 lb				
144.4	-	-	213.8	-	-
150.9	-	-	213.8	-	-
160.8	-	-	213.0	-	213.8
164.0	-	-	212.7	-	212.5
177.2	-	-	211.6	-	207.2
190.3	-	-	209.4	-	201.4
196.9	-	-	207.8	180.8	198.4
203.4	-	-	206.1	180.8	195.8
216.5	-	-	185.2	180.8	190.7
229.7	-	-	165.3	180.8	184.8
242.8	-	-	147.7	178.6	176.4
246.1	-	-	143.3	174.7	154.3
255.9	-	-	130.1	163.1	154.3
265.7	-	-	116.8	149.9	153.5
269.0	-	-	-	145.5	153.2
282.2	-	-	-	129.0	143.3
285.4	-	-	-	124.6	141.1
295.3	-	-	-	-	134.5
301.8	-	-	-	-	131.2
308.4	-	-	-	-	102.9
321.5	-	-	-	-	88.7
334.6	-	-	-	-	74.3
337.9	-	-	-	-	70.5

0 lb 143,300 lb 275,600 lb 363,800 lb			
452,000 lb 540,200 lb 628,400 lb 716,600 lb			

* Main boom angle 85°
Main boom angle 87°, 85°, 75°, 65° and 55°, capacities for intermediate boom positions are calculated by the crane control system IC-1

Operation

SWSL, SFSL

363,800 lb + 110,200 lb 36.1-62.3 ft						27.6 ft 32.2 ft/s 360° ASME B30.5					
118.1 ft + 275.6 ft						137.8 ft + 78.7 ft					
SWSL_1			SFSL_1			SWSL_1			SFSL_1		
0 lb			0 lb - 716,600 lb			0 lb			0 lb - 716,600 lb		
87°/85°		87°/85°		75°		65°		55°		15°	
ft	1,000 lb					ft	1,000 lb				
160.8	-	-	146.6	-	-	36.1	-	765.0	-	-	-
164.0	-	-	146.6	-	-	39.4	513.7	765.0	-	-	-
177.2	-	-	145.5	-	-	45.9	445.3	765.0*	-	-	-
180.4	-	-	145.2	-	-	52.5	390.2	765.0*	-	-	765.0
190.3	-	-	144.4	-	-	59.1	348.3	765.0*	-	-	765.0
203.4	-	-	143.3	-	-	65.6	315.3	765.0*	-	-	765.0
216.5	-	-	141.1	-	-	72.2	286.6	729.7*	-	-	765.0
219.8	-	-	140.8	121.3	-	78.7	253.5	641.5*	-	-	765.0
229.7	-	-	140.0	121.3	-	82.0	241.4	596.4*	734.1	-	736.3
242.8	-	-	138.9	121.3	-	85.3	229.3	551.2*	707.7	-	707.7
255.9	-	-	136.7	121.3	-	88.6	217.2	510.4*	681.2	-	680.1
269.0	-	-	123.5	121.3	-	91.9	202.8*	469.6*	654.8	-	652.6
275.6	-	-	116.8	121.3	104.9	95.1	194.0*	427.7*	632.7	-	628.3
282.2	-	-	110.2	121.3	104.9	98.4	-	-	610.7	-	604.1
295.3	-	-	97.9	121.3	104.9	111.5	-	-	537.9	-	529.1
305.1	-	-	87.5	113.0	104.9	118.1	-	-	469.6	491.6	491.6
308.4	-	-	-	110.2	104.9	124.7	-	-	-	465.2	464.4
321.5	-	-	-	97.9	104.9	137.8	-	-	-	416.7	410.1
324.8	-	-	-	94.4	104.9	141.1	-	-	-	405.7	397.9
334.6	-	-	-	-	104.9	150.9	-	-	-	-	363.8
341.2	-	-	-	-	102.1	164.0	-	-	-	-	330.7
347.8	-	-	-	-	-	177.2	-	-	-	-	271.2
360.9	-	-	-	-	-	190.3	-	-	-	-	234.4
374.0	-	-	-	-	-	203.4	-	-	-	-	205.0
377.3	-	-	-	-	50.3						

118.1 ft + 315.0 ft					
ft	1,000 lb				
177.2	-	-	102.5	-	-
190.3	-	-	101.6	-	-
200.1	-	-	101.0	-	101.6
203.4	-	-	100.8	-	100.9
216.5	-	-	99.6	-	97.9
229.7	-	-	98.3	-	95.1
242.8	-	-	97.2	83.6	92.2
255.9	-	-	96.1	83.6	89.3
269.0	-	-	94.8	83.6	86.5
282.2	-	-	93.9	83.6	83.8
295.3	-	-	93.0	83.6	81.1
301.8	-	-	92.6	83.6	80.0
308.4	-	-	92.2	83.6	78.8
321.5	-	-	83.6	83.6	76.6
334.6	-	-	73.6	83.6	74.5
341.2	-	-	68.1	83.6	73.7
347.8	-	-	-	83.6	70.1
360.9	-	-	-	74.1	70.1
374.0	-	-	-	-	70.1
380.6	-	-	-	-	70.1
387.1	-	-	-	-	56.9
400.3	-	-	-	-	46.9
413.4	-	-	-	-	36.6

137.8 ft + 118.1 ft					
ft	1,000 lb				
45.9	410.1	639.3	-	-	-
52.5	361.6	630.5	-	-	-
59.1	324.1	648.2*	-	-	-
65.6	291.0	639.3*	-	-	-
68.9	278.9	633.8*	-	-	628.3
72.2	266.8	628.3*	-	-	623.9
78.7	244.7	617.3*	-	-	621.7
85.3	224.9	588.6*	-	-	617.3
91.9	203.9	533.5*	-	-	615.1
98.4	185.2	478.4*	604.1	-	608.5
111.5	156.5	388.0*	531.3	-	533.5
124.7	135.6	313.1*	471.8	-	468.1
128.0	131.2	294.3*	451.4	-	454.2
131.2	123.5*	275.6*	431.0	-	440.2
137.8	-	-	390.2	-	412.3
141.1	-	-	372.6	399.0	401.2
150.9	-	-	319.7	368.2	368.2
157.5	-	-	282.2	351.6	346.1
164.0	-	-	-	335.1	329.2
177.2	-	-	-	306.4	295.4
180.4	-	-	-	297.6	288.8
190.3	-	-	-	-	271.2
200.1	-	-	-	-	255.7
203.4	-	-	-	-	229.6
216.5	-	-	-	-	206.1
229.7	-	-	-	-	178.2
239.5	-	-	-	-	163.1

	0 lb	143,300 lb	275,600 lb	363,800 lb
	452,000 lb	540,200 lb	628,400 lb	716,600 lb

* Main boom angle 85°

Main boom angle 87°, 85°, 75°, 65° and 55°, capacities for intermediate boom positions are calculated by the crane control system IC-1

Operation

SWSL, SFSL

 363,800 lb +
  110,200 lb
  36.1-62.3 ft
  27.6 ft
  32.2 ft/s
 360° ASME B30.5

137.8 ft + 157.5 ft

ft	SWSL_1					SFSL_1
	0 lb	0 lb - 716,600 lb				
	87°/85°	87°/85°	75°	65°	55°	15°
	1,000 lb					
55.8	317.5	447.5	-	-	-	-
59.1	299.8	447.5	-	-	-	-
65.6	271.2	451.9*	-	-	-	-
72.2	246.9	451.9*	-	-	-	-
78.7	227.1	449.7*	-	-	-	-
82.0	218.3	447.5*	-	-	-	443.1
85.3	209.4	445.3*	-	-	-	443.1
91.9	194.0	443.1*	-	-	-	443.1
98.4	180.8	436.5*	-	-	-	443.1
111.5	154.3	416.7*	-	-	-	436.5
114.8	148.8	400.1*	421.1	-	-	436.5
124.7	132.3	350.5*	421.1	-	-	429.9
137.8	115.7	297.6*	414.5	-	-	416.7
150.9	101.9	253.5*	352.7	-	-	372.6
164.0	90.6	213.8*	302.0	328.5	-	333.6
167.3	88.2	203.4*	291.6	321.9	-	325.2
170.6	83.3*	192.9*	281.1	314.5	-	316.7
177.2	-	-	260.1	299.8	-	299.8
190.3	-	-	220.5	275.6	-	273.4
193.6	-	-	210.5	270.6	-	266.8
203.4	-	-	-	255.7	-	248.4
206.7	-	-	-	246.9	242.5	242.5
216.5	-	-	-	220.5	229.3	224.9
229.7	-	-	-	-	213.8	199.2
239.5	-	-	-	-	202.8	181.0
242.8	-	-	-	-	-	176.8
255.9	-	-	-	-	-	158.7
269.0	-	-	-	-	-	138.2
278.9	-	-	-	-	-	126.8

137.8 ft + 236.2 ft

ft	SWSL_1					SFSL_1
	0 lb	0 lb - 716,600 lb				
	87°/85°	87°/85°	75°	65°	55°	15°
	1,000 lb					
72.2	216.1	231.5	-	-	-	-
78.7	198.4	229.3	-	-	-	-
85.3	183.0	229.3*	-	-	-	-
91.9	169.8	227.1*	-	-	-	-
98.4	157.6	227.1*	-	-	-	-
111.5	136.7	224.9*	-	-	-	224.9
124.7	120.2	220.5*	-	-	-	221.2
137.8	107.4	217.2*	-	-	-	218.3
147.6	98.8	213.8*	203.9	-	-	215.0
150.9	95.9	212.7*	203.9	-	-	213.8
164.0	84.7	208.3*	203.9	-	-	208.7
177.2	75.0	203.9*	203.9	-	-	202.8
190.3	66.8	187.4*	203.9	-	-	197.7
203.4	59.7	166.4*	202.8	-	-	191.4
206.7	58.2	161.5*	200.1	172.0	-	190.1
216.5	53.6	146.6*	191.8	172.0	-	186.3
229.7	48.1	129.0*	170.9	172.0	-	181.1
242.8	43.2	110.2*	152.1	172.0	-	176.0
246.1	39.9*	105.8*	147.7	172.0	-	174.7
255.9	-	-	134.5	172.0	-	170.9
259.2	-	-	130.1	167.8	145.5	169.8
269.0	-	-	116.8	155.4	145.5	161.2
272.3	-	-	111.3	151.0	145.5	158.3
282.2	-	-	-	137.8	145.5	147.7
292.0	-	-	-	124.6	144.7	136.1
295.3	-	-	-	-	144.4	132.3
308.4	-	-	-	-	135.6	121.3
315.0	-	-	-	-	129.0	115.7
321.5	-	-	-	-	-	108.8
334.6	-	-	-	-	-	96.3
347.8	-	-	-	-	-	84.6
354.3	-	-	-	-	-	78.7

137.8 ft + 196.9 ft

ft	SWSL_1					SFSL_1
	0 lb	0 lb - 716,600 lb				
	87°/85°	87°/85°	75°	65°	55°	15°
	1,000 lb					
65.6	253.5	319.7	-	-	-	-
72.2	231.5	317.5	-	-	-	-
78.7	212.7	319.7*	-	-	-	-
85.3	196.2	319.7*	-	-	-	-
91.9	181.9	317.5*	-	-	-	-
98.4	168.7	317.5*	-	-	-	317.5
111.5	147.7	313.1*	-	-	-	314.5
124.7	130.1	306.4*	-	-	-	310.9
131.2	121.3	304.2*	293.2	-	-	308.6
137.8	112.4	302.0*	293.2	-	-	306.4
150.9	99.2	266.8*	291.0	-	-	299.1
164.0	87.7	231.5*	291.0	-	-	289.5
177.2	78.3	202.8*	271.2	-	-	282.2
183.7	74.2	189.6*	253.5	249.1	-	274.8
190.3	70.1	176.4*	235.9	249.1	-	267.5
203.4	63.3	149.9*	208.3	249.1	-	249.9
210.0	58.2*	135.6*	195.1	241.4	-	239.6
216.5	-	-	181.9	233.7	-	229.3
229.7	-	-	156.5	210.5	-	211.6
232.9	-	-	149.9	204.2	206.1	207.2
242.8	-	-	-	185.2	195.1	192.9
255.9	-	-	-	159.8	181.9	173.1
269.0	-	-	-	-	170.9	153.7
275.6	-	-	-	-	165.3	147.7
282.2	-	-	-	-	-	139.6
295.3	-	-	-	-	-	123.5
308.4	-	-	-	-	-	109.0
318.2	-	-	-	-	-	98.8

0 lb
143,300 lb
275,600 lb
363,800 lb
452,000 lb
540,200 lb
628,400 lb
716,600 lb

* Main boom angle 85°
 Main boom angle 87°, 85°, 75°, 65° and 55°, capacities for intermediate boom positions are calculated by the crane control system IC-1

Operation

SWSL, SFSL

363,800 lb + 110,200 lb 36.1-62.3 ft							27.6 ft 32.2 ft/s 360° ASME B30.5						
137.8 ft + 275.6 ft							137.8 ft + 315.0 ft						
SWSL_1 SFSL_1							SWSL_1 SFSL_1						
0 lb 0 lb - 716,600 lb							0 lb 0 lb - 716,600 lb						
87°/85° 87°/85° 75° 65° 55° 15°							87°/85° 87°/85° 75° 65° 55° 15°						
ft	1,000 lb						ft	1,000 lb					
82.0	162.0	165.3	-	-	-	-	91.9	116.8	120.2	-	-	-	-
85.3	162.0	164.2	-	-	-	-	98.4	115.7	119.0	-	-	-	-
91.9	157.6	163.1	-	-	-	-	111.5	113.5	115.7*	-	-	-	-
98.4	145.5	162.0*	-	-	-	-	124.7	102.3	113.5*	-	-	-	-
111.5	126.8	159.8*	-	-	-	-	131.2	96.0	112.4*	-	-	-	-
118.1	119.0	158.2*	-	-	-	157.6	137.8	89.7	111.3*	-	-	-	111.3
124.7	111.3	156.5*	-	-	-	156.5	150.9	78.9	110.0*	-	-	-	109.7
137.8	98.3	154.3*	-	-	-	154.3	164.0	69.9	107.8*	-	-	-	107.3
150.9	87.1	151.0*	-	-	-	151.4	177.2	61.9	105.4*	-	-	-	104.5
164.0	77.6	148.8*	141.1	-	-	148.1	180.4	60.2	104.8*	98.5	-	-	103.8
177.2	69.4	145.5*	141.1	-	-	144.4	190.3	54.9	103.2*	98.1	-	-	101.7
190.3	62.4	142.2*	140.0	-	-	140.0	203.4	48.7	101.2*	97.7	-	-	98.8
203.4	56.0	140.0*	138.9	-	-	136.0	216.5	43.2	99.0*	96.8	-	-	95.9
216.5	49.8	137.8*	137.8	-	-	132.3	229.7	38.4	96.8*	95.9	-	-	93.0
229.7	44.1	135.6*	136.7	115.7	-	128.6	242.8	34.0	95.0*	95.0	-	-	90.1
242.8	39.0	122.4*	136.7	115.7	-	125.1	252.6	31.0	93.7*	94.2	79.4	-	88.0
255.9	34.4	109.3*	135.6	115.7	-	121.3	255.9	30.0	93.3*	93.9	79.4	-	87.3
269.0	30.4	96.1*	127.9	115.7	-	118.3	269.0	26.2	91.5*	93.0	79.4	-	84.7
278.9	27.8	85.9*	117.9	115.7	-	115.2	282.2	22.5	89.5*	92.2	79.4	-	82.0
282.2	25.1*	82.5*	114.6	115.7	-	114.3	295.3	19.4	80.9*	91.5	79.4	-	79.4
285.4	24.3*	78.7*	111.4	115.7	99.2	113.5	308.4	16.3	70.8*	90.8	79.4	-	77.0
295.3	-	-	101.6	115.7	99.2	111.3	315.0	15.0	65.4*	88.3	79.4	65.7	75.8
308.4	-	-	88.2	115.7	99.2	109.1	318.2	14.3	62.7*	87.0	79.4	65.7	75.3
321.5	-	-	-	105.2	99.2	106.8	321.5	11.9*	60.0*	85.8	79.4	65.7	74.7
331.4	-	-	-	95.2	99.2	104.9	334.6	-	-	75.8	79.4	65.7	72.5
334.6	-	-	-	-	99.2	104.3	347.8	-	-	65.3	79.4	65.7	70.8
347.8	-	-	-	-	99.2	95.2	360.9	-	-	-	79.1	65.7	69.1
351.1	-	-	-	-	99.2	92.4	370.7	-	-	-	71.4	65.7	67.9
360.9	-	-	-	-	-	83.8	374.0	-	-	-	-	65.7	67.5
374.0	-	-	-	-	-	75.6	387.1	-	-	-	-	65.7	66.3
387.1	-	-	-	-	-	64.4	390.4	-	-	-	-	65.7	66.0
393.7	-	-	-	-	-	58.9	400.3	-	-	-	-	-	62.6
							413.4	-	-	-	-	-	56.4
							426.5	-	-	-	-	-	46.6
							429.8	-	-	-	-	-	44.1

	0 lb	143,300 lb	275,600 lb	363,800 lb
	452,000 lb	540,200 lb	628,400 lb	716,600 lb

* Main boom angle 85°

Main boom angle 87°, 85°, 75°, 65° and 55°, capacities for intermediate boom positions are calculated by the crane control system IC-1

Operation

SWSL, SFSL

363,800 lb + 110,200 lb 36.1-68.9 ft 27.6 ft 32.2 ft/s 360° ASME B30.5															
157.5 ft + 78.7 ft					157.5 ft + 157.5 ft										
0 lb		SWSL_1			SFSL_1	SFSL_3									
0 lb - 716,600 lb		0 lb - 716,600 lb			0 lb - 716,600 lb										
ft	87°/85°	87°/85°	75°	65°	55°	15°	15°	ft	87°/85°	87°/85°	75°	65°	55°	15°	15°
1,000 lb															
39.4	489.4	765.0	-	-	-	-	-	55.8	304.2	416.7	-	-	-	-	-
45.9	425.5	765.0*	-	-	-	-	-	59.1	288.8	414.5	-	-	-	-	-
52.5	374.8	765.0*	-	-	-	765.0	765.0	65.6	262.4	421.1*	-	-	-	-	-
59.1	335.1	765.0*	-	-	-	765.0	765.0	72.2	238.1	421.1*	-	-	-	-	-
65.6	304.2	756.2*	-	-	-	765.0	765.0	78.7	220.5	416.7*	-	-	-	407.9	-
72.2	277.8	723.1*	-	-	-	765.0	765.0	85.3	202.8	414.5*	-	-	-	407.9	432.1
78.7	253.5	663.6*	-	-	-	760.6	765.0	91.9	188.5	410.1*	-	-	-	407.9	432.1
85.3	227.1	577.6*	-	-	-	703.3	760.6	98.4	175.3	405.7*	-	-	-	407.9	432.1
88.6	216.6	535.7*	672.4	-	-	675.7	733.0	111.5	153.2	394.6*	-	-	-	403.4	427.7
91.9	206.1	493.8*	648.2	-	-	648.2	705.5	121.4	136.7	368.2*	390.2	-	-	400.1	422.2
95.1	191.8*	454.2*	626.1	-	-	623.9	680.1	124.7	131.2	359.4*	390.2	-	-	399.0	421.1
98.4	-	-	604.1	-	-	599.7	654.8	137.8	114.6	306.4*	388.0	-	-	394.6	418.9
111.5	-	-	531.3	-	-	524.7	573.9	150.9	101.0	260.1*	372.6	-	-	362.3	395.4
124.7	-	-	451.9	-	-	460.0	503.4	164.0	89.9	220.5*	321.9	-	-	329.2	366.0
128.0	-	-	-	-	-	446.4	488.3	167.3	87.5	209.8*	310.3	-	-	320.8	357.1
137.8	-	-	-	410.1	-	405.7	443.1	170.6	82.2*	199.2*	298.7	308.6	-	312.3	348.3
150.9	-	-	-	368.2	-	361.6	399.0	173.9	79.8*	188.5*	287.2	302.0	-	303.9	339.5
160.8	-	-	-	-	330.7	331.1	366.7	177.2	-	-	275.6	295.4	-	295.4	330.7
164.0	-	-	-	-	321.9	322.6	356.4	190.3	-	-	235.9	271.2	-	269.0	301.3
173.9	-	-	-	-	302.0	297.3	325.5	200.1	-	-	206.1	254.6	-	250.2	281.1
177.2	-	-	-	-	-	288.8	315.3	203.4	-	-	-	249.1	-	244.7	275.6
190.3	-	-	-	-	-	253.5	274.1	216.5	-	-	-	231.5	222.7	222.7	253.5
203.4	-	-	-	-	-	218.3	242.1	226.4	-	-	-	218.3	211.3	210.0	235.9
216.5	-	-	-	-	-	191.8	207.2	229.7	-	-	-	-	207.2	205.8	230.0
219.8	-	-	-	-	-	183.0	201.7	242.8	-	-	-	-	194.0	189.6	206.1
								249.3	-	-	-	-	188.5	178.6	194.0
								255.9	-	-	-	-	-	167.6	184.1
								269.0	-	-	-	-	-	149.2	165.0
								282.2	-	-	-	-	-	133.4	144.8
								295.3	-	-	-	-	-	114.6	127.9

157.5 ft + 118.1 ft									
ft	1,000 lb								
45.9	392.4	582.0	-	-	-	-	-	-	-
52.5	348.3	575.4	-	-	-	-	-	-	-
59.1	310.9	593.0*	-	-	-	-	-	-	-
65.6	282.2	586.4*	-	-	-	571.0	-	-	-
72.2	257.9	577.6*	-	-	-	571.0	601.9	-	-
78.7	235.9	568.8*	-	-	-	568.8	595.2	-	-
85.3	218.3	551.2*	-	-	-	566.6	588.6	-	-
91.9	202.8	535.7*	-	-	-	562.2	586.4	-	-
98.4	185.2	496.0*	-	-	-	560.0	582.0	-	-
105.0	170.9	448.6*	560.0	-	-	534.3	565.9	-	-
111.5	156.5	401.2*	524.7	-	-	512.9	551.9	-	-
124.7	135.6	326.3*	467.4	-	-	464.4	508.5	-	-
128.0	130.1	307.9*	455.8	-	-	450.8	493.8	-	-
134.5	117.9*	271.2*	432.7	-	-	423.7	464.4	-	-
137.8	-	-	421.1	-	-	410.1	449.7	-	-
150.9	-	-	348.3	363.8	-	366.0	402.7	-	-
160.8	-	-	295.4	337.3	-	335.5	370.7	-	-
164.0	-	-	-	328.5	-	327.0	362.3	-	-
177.2	-	-	-	299.8	-	293.2	328.5	-	-
187.0	-	-	-	282.2	-	273.4	307.5	-	-
190.3	-	-	-	-	266.8	266.8	300.6	-	-
203.4	-	-	-	-	244.7	242.1	269.7	-	-
213.3	-	-	-	-	233.7	225.1	244.3	-	-
216.5	-	-	-	-	-	219.4	235.9	-	-
229.7	-	-	-	-	-	192.2	211.6	-	-
242.8	-	-	-	-	-	170.6	186.7	-	-
255.9	-	-	-	-	-	147.7	162.0	-	-
259.2	-	-	-	-	-	142.2	157.6	-	-

	0 lb	143,300 lb	275,600 lb	363,800 lb
	452,000 lb	540,200 lb	628,400 lb	716,600 lb

SWSL_1: 36.1 ft – 62.3 ft

SWSL_3/SFSL_3: 36.1 ft – 68.9 ft

SFSL_3: 496,100 lb + 110,200 lb

* Main boom angle 85°

Main boom angle 87°, 85°, 75°, 65° and 55°, capacities for intermediate boom positions are calculated by the crane control system IC-1

Operation

SWSL, SFSL

363,800 lb + 110,200 lb 36.1-68.9 ft 27.6 ft 32.2 ft/s 360° ASME B30.5									
157.5 ft + 196.9 ft					157.5 ft + 236.2 ft				
SWSL_1					SWSL_1				
SFSL_1					SFSL_1				
SFSL_3					SFSL_3				
0 lb					0 lb - 716,600 lb				
87°/85°					87°/85°				
75°					75°				
65°					65°				
55°					55°				
15°					15°				
15°					15°				
ft					ft				
1,000 lb					1,000 lb				
65.6	244.7	302.0	-	-	-	-	-	-	-
72.2	222.7	299.8	-	-	-	-	-	-	-
78.7	205.0	302.0*	-	-	-	-	-	-	-
85.3	189.6	302.0*	-	-	-	-	-	-	-
91.9	176.4	302.0*	-	-	-	-	-	-	-
95.1	169.8	300.9*	-	-	-	297.6	310.9	-	-
98.4	163.1	299.8*	-	-	-	297.6	310.9	-	-
111.5	143.3	295.4*	-	-	-	296.2	310.9	-	-
124.7	126.8	291.0*	-	-	-	293.9	309.4	-	-
137.8	112.4	284.4*	273.4	-	-	291.0	306.4	-	-
150.9	98.5	271.2*	273.4	-	-	282.9	299.1	-	-
164.0	87.1	235.9*	273.4	-	-	276.3	291.0	-	-
177.2	77.6	206.1*	273.4	-	-	269.0	282.2	-	-
190.3	69.4	179.7*	249.1	-	-	261.6	271.9	-	-
193.6	67.8	173.3*	241.7	233.7	-	259.8	269.3	-	-
203.4	62.8	154.3*	219.4	233.7	-	246.9	260.9	-	-
210.0	57.1*	140.0*	205.6	231.5	-	235.9	255.0	-	-
216.5	-	-	191.8	229.3	-	224.9	249.1	-	-
229.7	-	-	167.6	212.7	-	208.0	235.9	-	-
239.5	-	-	146.6	202.8	-	195.7	224.5	-	-
242.8	-	-	-	199.5	189.6	191.8	219.7	-	-
255.9	-	-	-	176.4	177.5	177.5	200.6	-	-
262.5	-	-	-	163.1	172.5	170.1	190.7	-	-
269.0	-	-	-	-	167.6	162.8	180.8	-	-
282.2	-	-	-	-	157.6	147.0	161.3	-	-
288.7	-	-	-	-	153.2	138.5	152.7	-	-
295.3	-	-	-	-	-	130.1	145.5	-	-
308.4	-	-	-	-	-	117.2	130.1	-	-
321.5	-	-	-	-	-	103.6	113.9	-	-
334.6	-	-	-	-	-	92.4	101.6	-	-
75.5	199.5	219.4	-	-	-	-	-	215.0	220.5
78.7	191.8	219.4	-	-	-	-	-	214.6	220.5
85.3	176.4	218.3	-	-	-	-	-	212.7	219.7
91.9	164.2	218.3*	-	-	-	-	-	210.5	218.3
98.4	152.1	218.3*	-	-	-	-	-	205.0	212.7
108.3	137.2	216.6*	-	-	-	-	-	201.7	209.1
111.5	132.3	216.1*	-	-	-	-	-	197.3*	203.9
124.7	116.8	212.7*	-	-	-	-	-	190.7*	198.4
137.8	103.8	209.4*	-	-	-	-	-	169.8*	193.6
150.9	92.8	205.0*	-	-	-	-	-	154.9*	189.8
154.2	90.4	203.9*	192.9	-	-	-	-	149.9*	188.5
164.0	83.1	200.6*	192.9	-	-	-	-	132.3*	183.4
177.2	74.3	197.3*	192.9	-	-	-	-	114.6*	178.2
190.3	66.1	190.7*	192.9	-	-	-	-	104.7*	175.6
203.4	59.3	169.8*	192.9	-	-	-	-	142.2	173.1
213.3	54.7	154.9*	192.9	159.8	-	-	-	124.6	165.7
216.5	53.1	149.9*	192.9	159.8	-	-	-	115.7	162.0
229.7	47.4	132.3*	179.7	159.8	-	-	-	148.8	158.4
242.8	42.5	114.6*	159.8	159.8	-	-	-	137.8	152.7
249.3	37.9*	104.7*	151.0	159.8	-	-	-	137.8	149.9
255.9	-	-	142.2	159.8	-	-	-	123.5	144.0
269.0	-	-	124.6	159.8	137.8	-	-	136.7	138.2
275.6	-	-	115.7	156.2	137.8	158.7	-	129.0	125.3
282.2	-	-	-	148.8	137.8	142.2	149.9	127.9	122.9
295.3	-	-	-	132.3	137.8	142.2	149.9	-	115.7
301.8	-	-	-	123.5	137.2	134.8	144.0	-	104.3
308.4	-	-	-	-	136.7	127.5	138.2	-	92.2
321.5	-	-	-	-	129.0	113.7	125.3	-	79.6
324.8	-	-	-	-	127.9	110.5	122.9	-	88.3
334.6	-	-	-	-	-	104.3	115.7	-	73.9
347.8	-	-	-	-	-	92.2	102.1	-	81.1
360.9	-	-	-	-	-	79.6	88.3	-	-
370.7	-	-	-	-	-	73.9	81.1	-	-

SWSL_1: 36.1 ft – 62.3 ft

SWSL_3/SFSL_3: 36.1 ft – 68.9 ft































SFSL_3: 496,100 lb + 110,200 lb

* Main boom angle 85°



Main boom angle 87°, 85°, 75°, 65° and 55°, capacities for intermediate boom positions are calculated by the crane control system IC-1

Operation

SWSL, SFSL

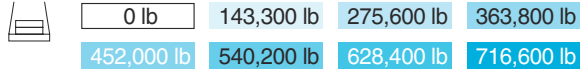
 363,800 lb + 110,200 lb  36.1-68.9 ft  27.6 ft  32.2 ft/s  360°  ASME B30.5									
 157.5 ft + 275.6 ft					 157.5 ft + 315.0 ft				
 SWSL_1  SFSL_1  SFSL_3					 SWSL_1  SFSL_1  SFSL_3				
 0 lb  0 lb - 716,600 lb					 0 lb  0 lb - 716,600 lb				
 87°/85°  87°/85°  75°  65°  55°  15°  15°					 87°/85°  87°/85°  75°  65°  55°  15° 15°				
ft					ft				
1,000 lb					1,000 lb				
82.0	155.4	158.7	-	-	-	-	-	-	-
85.3	155.4	157.6	-	-	-	-	-	-	-
91.9	152.1	156.5	-	-	-	-	-	-	-
98.4	141.1	155.4*	-	-	-	-	-	-	-
111.5	122.4	154.3*	-	-	-	-	-	-	-
121.4	111.3	152.7*	-	-	-	151.0	156.5	-	-
124.7	107.6	152.1*	-	-	-	150.6	156.1	-	-
137.8	95.0	148.8*	-	-	-	148.8	154.3	-	-
150.9	84.2	146.6*	-	-	-	145.9	151.4	-	-
164.0	75.0	144.4*	-	-	-	142.9	148.1	-	-
170.6	71.0	142.7*	134.5	-	-	141.5	146.2	-	-
177.2	67.0	141.1*	134.5	-	-	140.0	144.4	-	-
190.3	60.0	138.9*	134.5	-	-	136.3	140.7	-	-
203.4	53.8	136.7*	134.5	-	-	132.6	137.1	-	-
216.5	48.3	134.5*	133.4	-	-	129.0	133.4	-	-
229.7	43.4	132.3*	133.4	-	-	126.0	129.7	-	-
236.2	40.9	129.0*	132.8	110.2	-	124.6	127.9	-	-
242.8	38.4	125.7*	132.3	110.2	-	122.4	126.0	-	-
255.9	34.0	111.3*	132.3	110.2	-	119.0	122.4	-	-
269.0	30.0	99.0*	131.2	110.2	-	115.4	117.9	-	-
282.2	26.5	85.5*	120.2	110.2	-	112.3	114.6	-	-
285.4	23.4*	81.8*	117.0	110.2	-	111.7	113.5	-	-
295.3	-	-	107.6	110.2	-	109.8	110.2	-	-
298.6	-	-	104.4	110.2	93.9	108.9	109.5	-	-
308.4	-	-	94.6	110.2	93.9	106.9	107.1	-	-
315.0	-	-	87.3	110.2	93.9	105.6	105.6	-	-
321.5	-	-	-	110.2	93.9	104.3	103.8	-	-
334.6	-	-	-	101.2	93.9	101.6	100.1	-	-
341.2	-	-	-	94.4	93.9	98.8	98.0	-	-
347.8	-	-	-	-	93.9	96.3	95.8	-	-
360.9	-	-	-	-	93.9	88.8	91.3	-	-
364.2	-	-	-	-	93.9	87.0	90.1	-	-
374.0	-	-	-	-	-	81.4	86.2	-	-
387.1	-	-	-	-	-	70.5	76.9	-	-
400.3	-	-	-	-	-	60.1	67.2	-	-
410.1	-	-	-	-	-	55.3	61.1	-	-
91.9	112.4	114.6	-	-	-	-	-	-	-
98.4	111.3	113.5	-	-	-	-	-	-	-
111.5	109.8	111.3*	-	-	-	-	-	-	-
124.7	98.5	110.2*	-	-	-	-	-	-	-
134.5	89.5	108.9*	-	-	-	-	-	108.5	110.2
137.8	86.4	108.5*	-	-	-	-	-	108.0	110.2
150.9	76.1	106.5*	-	-	-	-	-	106.3	107.7
164.0	67.2	104.5*	-	-	-	-	-	104.1	105.4
177.2	59.5	102.5*	-	-	-	-	-	101.6	103.2
187.0	54.4	101.0*	94.1	-	-	-	-	99.6	101.4
190.3	52.7	100.5*	94.1	-	-	-	-	99.0	100.8
203.4	46.7	98.5*	93.9	-	-	-	-	96.2	98.4
216.5	41.4	96.6*	93.5	-	-	-	-	93.3	95.9
229.7	36.6	94.6*	92.8	-	-	-	-	90.6	93.3
242.8	32.2	92.8*	92.2	-	-	-	-	88.0	90.4
255.9	28.4	91.1*	91.3	-	-	-	-	85.3	87.3
259.2	27.6	90.7*	91.2	75.2	-	-	-	84.7	86.6
269.0	24.9	89.5*	90.6	75.2	-	-	-	82.7	84.3
282.2	21.6	87.7*	89.9	75.2	-	-	-	80.2	81.4
295.3	18.7	83.1*	89.5	75.2	-	-	-	77.8	78.3
308.4	15.9	73.0*	88.8	75.2	-	-	-	75.5	75.3
318.2	13.9	65.3*	88.5	75.2	-	-	-	73.7	73.2
321.5	11.2*	62.6*	88.4	75.2	-	-	-	73.2	72.6
324.8	10.6*	59.5*	86.4	75.2	61.9	-	-	72.6	72.0
334.6	-	-	80.5	75.2	61.9	71.0	-	70.1	-
347.8	-	-	70.3	75.2	61.9	69.1	-	67.6	-
351.1	-	-	67.7	75.2	61.9	68.6	-	67.0	-
360.9	-	-	-	75.2	61.9	67.3	-	65.1	-
374.0	-	-	-	75.2	61.9	65.7	-	62.6	-
377.3	-	-	-	73.6	61.9	65.3	-	61.8	-
387.1	-	-	-	-	61.9	64.2	-	60.0	-
400.3	-	-	-	-	61.9	62.5	-	58.3	-
403.5	-	-	-	-	61.9	62.1	-	58.0	-
413.4	-	-	-	-	-	60.6	-	56.9	-
426.5	-	-	-	-	-	51.4	-	52.8	-
439.6	-	-	-	-	-	43.7	-	47.4	-
449.5	-	-	-	-	-	38.4	-	43.2	-



SWSL_1:  **36.1 ft - 62.3 ft**
 SWSL_3/SFSL_3:  **36.1 ft - 68.9 ft**

SFSL_3:  **496,100 lb + 110,200 lb**

* Main boom angle 85°

Main boom angle 87°, 85°, 75°, 65° and 55°, capacities for intermediate boom positions are calculated by the crane control system IC-1

Operation

SWSL, SFSL

363,800 lb + 110,200 lb 36.1-68.9 ft 27.6 ft 32.2 ft/s 360° ASME B30.5																			
177.2 ft + 78.7 ft					177.2 ft + 118.1 ft														
SWSL_1					SFSL_1	SFSL_3	SWSL_1					SFSL_1	SFSL_3						
0 lb					0 lb - 716,600 lb					0 lb					0 lb - 716,600 lb				
87°/85°					87°/85°					87°/85°					87°/85°				
75°					75°					75°					75°				
65°					65°					65°					65°				
55°					55°					55°					55°				
15°					15°					15°					15°				
ft					1,000 lb					ft					1,000 lb				
39.4	467.4	731.9	-	-	-	-	-	-	-	49.2	352.7	524.7	-	-	-	-	-	-	-
45.9	407.9	712.1	-	-	-	-	-	-	-	52.5	332.9	522.5	-	-	-	-	-	-	-
52.5	361.6	743.0*	-	-	-	-	-	-	-	59.1	299.8	537.9*	-	-	-	-	-	-	-
55.8	341.7	734.1*	-	-	-	-	-	-	-	65.6	271.2	531.3*	-	-	-	-	-	-	-
59.1	324.1	725.3*	-	-	-	-	-	-	-	68.9	260.1	526.9*	-	-	-	-	-	-	-
65.6	293.2	696.7*	-	-	-	-	-	-	-	72.2	249.1	522.5*	-	-	-	-	-	-	-
72.2	266.8	670.2*	-	-	-	-	-	-	-	78.7	229.3	513.7*	-	-	-	-	-	-	-
78.7	246.9	632.7*	-	-	-	-	-	-	-	85.3	211.6	502.7*	-	-	-	-	-	-	-
85.3	227.1	604.1*	-	-	-	-	-	-	-	91.9	196.2	489.4*	-	-	-	-	-	-	-
91.9	205.0	520.3*	-	-	-	-	-	-	-	98.4	184.1	474.0*	-	-	-	-	-	-	-
95.1	190.7*	478.4*	617.3	-	-	-	-	-	-	108.3	163.4	431.0*	511.5	-	-	-	-	-	-
98.4	181.9*	436.5*	597.5	-	-	-	-	-	-	111.5	156.5	416.7*	511.5	-	-	-	-	-	-
111.5	-	-	524.7	-	-	-	-	-	-	124.7	134.5	339.5*	463.0	-	-	-	-	-	-
124.7	-	-	467.4	-	-	-	-	-	-	131.2	125.7	300.9*	439.8	-	-	-	-	-	-
128.0	-	-	456.4	-	-	-	-	-	-	137.8	113.5*	262.4*	416.7	-	-	-	-	-	-
137.8	-	-	-	403.4	-	-	-	-	-	150.9	-	-	374.8	-	-	-	-	-	-
150.9	-	-	-	361.6	-	-	-	-	-	157.5	-	-	341.7	339.5	-	-	-	-	-
157.5	-	-	-	343.9	-	-	-	-	-	164.0	-	-	308.6	324.1	-	-	-	-	-
164.0	-	-	-	-	-	-	-	-	-	167.3	-	-	291.0	316.9	-	-	-	-	-
173.9	-	-	-	-	295.4	-	-	-	-	177.2	-	-	-	295.4	-	-	-	-	-
177.2	-	-	-	-	288.8	286.6	319.7	-	-	190.3	-	-	-	271.2	-	-	-	-	-
183.7	-	-	-	-	275.6	273.4	305.0	-	-	196.9	-	-	-	262.4	-	-	-	-	-
190.3	-	-	-	-	-	260.1	290.3	-	-	200.1	-	-	-	-	244.7	-	-	-	-
203.4	-	-	-	-	-	233.3	257.9	-	-	203.4	-	-	-	-	240.3	-	-	-	-
216.5	-	-	-	-	-	206.1	224.9	-	-	216.5	-	-	-	-	222.7	-	-	-	-
229.7	-	-	-	-	-	179.1	196.9	-	-	223.1	-	-	-	-	216.1	-	-	-	-
236.2	-	-	-	-	-	168.7	183.0	-	-	229.7	-	-	-	-	-	-	-	-	-
										242.8	-	-	-	-	-	-	-	-	-
										255.9	-	-	-	-	-	-	-	-	-
										269.0	-	-	-	-	-	-	-	-	-
										275.6	-	-	-	-	-	-	-	-	-

0 lb 143,300 lb 275,600 lb 363,800 lb
 452,000 lb 540,200 lb 628,400 lb 716,600 lb

SWSL_1: 36.1 ft – 62.3 ft
SWSL_3/SFSL_3: 36.1 ft – 68.9 ft
SFSL_3: 496,100 lb + 110,200 lb

* Main boom angle 85°

Main boom angle 87°, 85°, 75°, 65° and 55°, capacities for intermediate boom positions are calculated by the crane control system IC-1

Operation

SWSL, SFSL

363,800 lb + 110,200 lb 36.1-68.9 ft 27.6 ft 32.2 ft/s 360° ASME B30.5																																		
177.2 ft + 157.5 ft					177.2 ft + 196.9 ft																													
SWSL_1					SFSL_1	SFSL_3	SWSL_1					SFSL_1	SFSL_3																					
0 lb					0 lb - 716,600 lb					0 lb					0 lb - 716,600 lb																			
87°/85°					87°/85°					75°					65°					55°					15°					15°				
ft										1,000 lb																								
55.8	293.2	383.6	-	-	-	-	-	-	-	65.6	235.9	282.2	-	-	-	-	-	-	-															
59.1	277.8	381.4	-	-	-	-	-	-	-	72.2	216.1	280.0	-	-	-	-	-	-	-															
65.6	253.5	377.0	-	-	-	-	-	-	-	78.7	198.4	282.2*	-	-	-	-	-	-	-															
72.2	231.5	385.8*	-	-	-	-	-	-	-	85.3	183.0	282.2*	-	-	-	-	-	-	-															
78.7	212.7	383.6*	-	-	-	-	-	-	-	91.9	169.8	280.0*	-	-	-	-	-	-	-															
82.0	204.5	381.4*	-	-	-	-	-	-	-	95.1	164.2	280.0*	-	-	-	-	-	275.6	-															
85.3	196.2	379.2*	-	-	-	-	-	-	-	98.4	158.7	280.0*	-	-	-	-	-	275.6	-															
88.6	189.6	378.1*	-	-	-	-	-	-	-	101.7	153.8	278.9*	-	-	-	-	-	275.6	291.0															
91.9	183.0	377.0*	-	-	-	-	-	-	-	111.5	138.9	275.6*	-	-	-	-	-	275.6	291.0															
98.4	169.8	370.4*	-	-	-	-	-	-	-	124.7	122.4	269.0*	-	-	-	-	-	274.8	291.0															
111.5	148.8	359.4*	-	-	-	-	-	-	-	137.8	109.3	262.4*	-	-	-	-	-	273.4	291.0															
124.7	131.2	348.3*	361.6	-	-	-	-	-	-	141.1	106.5	260.7*	255.7	-	-	-	-	270.4	287.7															
137.8	114.6	315.3*	359.4	-	-	-	-	-	-	150.9	97.9	255.7*	255.7	-	-	-	-	268.2	284.4															
150.9	101.2	269.0*	359.4	-	-	-	-	-	-	164.0	86.4	242.5*	255.7	-	-	-	-	261.6	277.0															
164.0	89.9	229.3*	335.1	-	-	-	-	-	-	177.2	76.9	212.7*	255.7	-	-	-	-	255.7	271.2															
167.3	87.5	218.6*	325.2	-	-	-	-	-	-	190.3	68.8	185.2*	255.7	-	-	-	-	248.4	260.9															
173.9	79.4*	197.3*	305.3	-	-	-	-	-	-	200.1	63.8	165.3*	237.5	219.4	-	-	-	241.0	253.5															
177.2	-	-	295.4	-	-	-	-	-	-	203.4	62.2	158.7*	231.5	219.4	-	-	-	237.4	251.3															
180.4	-	-	284.9	284.4	-	-	-	-	-	206.7	60.6	151.8*	224.6	218.3	-	-	-	233.7	249.1															
190.3	-	-	253.5	266.8	-	-	-	-	-	213.3	54.7*	137.8*	210.8	218.3	-	-	-	226.3	244.7															
203.4	-	-	215.0	246.9	-	-	-	-	-	216.5	-	-	203.9	218.3	-	-	-	222.7	242.5															
216.5	-	-	-	229.3	-	-	-	-	-	229.7	-	-	178.6	208.3	-	-	-	205.0	230.8															
229.7	-	-	-	213.8	202.8	-	-	-	-	242.8	-	-	152.1	195.1	-	-	-	189.2	217.2															
232.9	-	-	-	209.4	199.5	199.3	227.4	-	-	255.9	-	-	-	183.0	173.1	-	-	174.2	201.7															
242.8	-	-	-	-	189.6	187.8	213.5	-	-	269.0	-	-	-	168.7	162.0	-	-	161.7	186.7															
255.9	-	-	-	-	177.5	173.1	195.1	-	-	272.3	-	-	-	162.0	159.8	-	-	158.5	183.0															
262.5	-	-	-	-	173.1	165.7	184.1	-	-	282.2	-	-	-	-	153.2	-	-	149.9	171.2															
269.0	-	-	-	-	-	158.4	173.4	-	-	295.3	-	-	-	-	144.4	-	-	138.9	154.3															
282.2	-	-	-	-	-	141.5	154.7	-	-	298.6	-	-	-	-	142.2	-	-	135.2	150.1															
295.3	-	-	-	-	-	124.6	140.0	-	-	308.4	-	-	-	-	-	-	-	124.2	137.4															
308.4	-	-	-	-	-	109.9	120.6	-	-	321.5	-	-	-	-	-	-	-	109.5	122.0															
311.7	-	-	-	-	-	106.3	115.7	-	-	334.6	-	-	-	-	-	-	-	99.9	110.2															
										347.8	-	-	-	-	-	-	-	85.1	94.5															
										351.1	-	-	-	-	-	-	-	81.4	90.6															

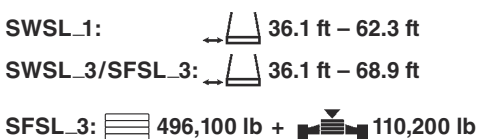

* Main boom angle 85°
 Main boom angle 87°, 85°, 75°, 65° and 55°, capacities for intermediate boom positions are calculated by the crane control system IC-1

Operation

SWSL, SFSL

363,800 lb + 110,200 lb 36.1-68.9 ft 27.6 ft 32.2 ft/s 360° ASME B30.5																																		
177.2 ft + 236.2 ft					177.2 ft + 275.6 ft																													
SWSL_1					SFSL_1					SFSL_3																								
0 lb					0 lb - 716,600 lb					0 lb					0 lb - 716,600 lb																			
87°/85°					87°/85°					75°					65°					55°					15°					15°				
ft										1,000 lb																								
75.5	192.9	207.2	-	-	-	-	-	-	-	85.3	147.7	151.0	-	-	-	-	-	-	-															
78.7	185.2	207.2	-	-	-	-	-	-	-	91.9	145.5	149.9	-	-	-	-	-	-	-															
85.3	170.9	206.1	-	-	-	-	-	-	-	98.4	135.6	148.8*	-	-	-	-	-	-	-															
91.9	157.6	206.1*	-	-	-	-	-	-	-	111.5	117.9	147.7*	-	-	-	-	-	-	-															
98.4	146.6	206.1*	-	-	-	-	-	-	-	121.4	107.4	146.1*	-	-	-	-	-	-	-															
108.3	132.6	204.5*	-	-	-	-	-	202.8	211.6	124.7	103.8	145.5*	-	-	-	-	145.5	151.0	150.6															
111.5	127.9	203.9*	-	-	-	-	-	202.8	211.6	137.8	91.5	143.3*	-	-	-	-	143.3	148.8	148.8															
124.7	112.4	201.7*	-	-	-	-	-	202.1	210.9	150.9	81.1	141.1*	-	-	-	-	141.1	145.9	145.9															
137.8	100.5	198.4*	-	-	-	-	-	200.6	209.4	164.0	72.3	138.9*	-	-	-	-	138.5	142.9	142.9															
150.9	89.7	195.1*	-	-	-	-	-	196.9	205.8	173.9	66.4	137.2*	127.9	-	-	-	136.3	140.7	140.7															
157.5	85.1	193.5*	181.9	-	-	-	-	195.1	203.9	177.2	64.4	136.7*	127.9	-	-	-	135.6	140.0	140.0															
164.0	80.5	191.8*	181.9	-	-	-	-	192.9	201.7	190.3	57.8	134.5*	127.9	-	-	-	132.6	136.3	136.3															
177.2	72.3	187.4*	181.9	-	-	-	-	188.5	197.3	203.4	51.6	131.2*	127.9	-	-	-	129.3	133.0	133.0															
190.3	65.5	184.1*	181.9	-	-	-	-	184.1	192.9	216.5	46.3	129.0*	127.9	-	-	-	125.7	130.1	130.1															
203.4	58.6	173.1*	181.9	-	-	-	-	178.6	187.4	229.7	41.7	127.9*	127.9	-	-	-	122.1	126.4	126.4															
216.5	52.5	153.2*	181.9	-	-	-	-	174.2	183.0	242.8	37.5	125.7*	127.9	-	-	-	119.4	122.7	122.7															
223.1	49.6	144.4*	181.9	151.0	-	-	-	172.0	180.4	246.1	36.5	122.9*	127.9	104.9	-	-	118.5	121.8	121.8															
229.7	46.7	135.6*	181.9	151.0	-	-	-	169.8	177.8	255.9	33.5	114.6*	127.9	104.9	-	-	115.7	119.0	119.0															
242.8	42.1	116.8*	167.6	151.0	-	-	-	165.1	173.1	269.0	29.5	101.4*	127.9	104.9	-	-	112.8	115.7	115.7															
249.3	36.8*	108.2*	158.7	151.0	-	-	-	162.5	170.9	282.2	26.0	88.0*	125.7	104.9	-	-	109.9	111.9	111.9															
255.9	-	-	149.9	151.0	-	-	-	159.8	168.7	288.7	21.8*	80.7*	119.0	104.9	-	-	108.4	110.3	110.3															
269.0	-	-	132.3	151.0	-	-	-	155.4	162.8	295.3	-	-	112.4	104.9	-	-	106.9	108.7	108.7															
282.2	-	-	113.5	151.0	130.1	-	-	148.4	155.8	308.4	-	-	100.3	104.9	88.4	-	104.1	105.1	105.1															
295.3	-	-	-	143.3	130.1	138.9	-	-	147.7	318.2	-	-	90.2	104.9	88.4	-	101.9	102.6	102.6															
308.4	-	-	-	126.8	130.1	129.3	-	-	140.4	321.5	-	-	-	104.9	88.4	-	101.2	101.7	101.7															
311.7	-	-	-	122.4	128.7	126.9	-	-	138.5	334.6	-	-	-	104.9	88.4	-	98.5	98.3	98.3															
321.5	-	-	-	-	124.6	119.4	-	-	131.2	347.8	-	-	-	96.8	88.4	-	96.0	94.9	94.9															
334.6	-	-	-	-	117.9	108.0	-	-	120.2	360.9	-	-	-	-	88.4	-	90.9	91.3	91.3															
337.9	-	-	-	-	-	116.8	-	-	104.9	374.0	-	-	-	-	88.4	-	83.1	86.2	86.2															
347.8	-	-	-	-	-	-	-	-	95.7	387.1	-	-	-	-	-	-	72.8	80.3	80.3															
360.9	-	-	-	-	-	-	-	-	85.0	400.3	-	-	-	-	-	-	65.5	72.1	72.1															
374.0	-	-	-	-	-	-	-	-	76.1	413.4	-	-	-	-	-	-	56.7	65.0	65.0															
387.1	-	-	-	-	-	-	-	-	63.9	426.5	-	-	-	-	-	-	47.0	53.8	53.8															
390.4	-	-	-	-	-	-	-	-	61.5																									

0 lb 143,300 lb 275,600 lb 363,800 lb 452,000 lb 540,200 lb 628,400 lb 716,600 lb

SWSL_1: 36.1 ft – 62.3 ft

SWSL_3/SFSL_3: 36.1 ft – 68.9 ft

SFSL_3: 496,100 lb + 110,200 lb

* Main boom angle 85°

Main boom angle 87°, 85°, 75°, 65° and 55°, capacities for intermediate boom positions are calculated by the crane control system IC-1

Operation

SWSL, SFSL

363,800 lb + 110,200 lb 36.1-68.9 ft							27.6 ft 32.2 ft/s 360° ASME B30.5								
177.2 ft + 315.0 ft							196.9 ft + 78.7 ft								
SWSL_1 SFSL_1 SFSL_3							SWSL_1 SFSL_1 SFSL_3 SFSL_4								
0 lb 0 lb -716,600 lb							0 lb 0 lb -716,600 lb								
87°/85° 87°/85° 75° 65° 55° 15° 15°							87°/85° 87°/85° 75° 65° 55° 15° 15° 15°								
ft							ft								
1,000 lb							1,000 lb								
91.9	108.0	110.2	-	-	-	-	39.4	-	659.2	-	-	-	-	-	
98.4	107.1	109.3	-	-	-	-	42.7	416.7	652.6	-	-	-	-	-	
111.5	105.2	107.6*	-	-	-	-	45.9	390.2	643.8	-	-	-	-	-	
124.7	94.8	106.0*	-	-	-	-	52.5	346.1	670.2*	-	-	-	-	-	
134.5	85.9	104.7*	-	-	-	104.3	55.8	328.5	663.6*	-	-	643.8	-	723.1	
137.8	82.9	104.3*	-	-	-	103.8	59.1	310.9	654.8*	-	-	643.8	-	723.1	
150.9	73.0	102.5*	-	-	-	102.2	62.3	295.4	646.0*	-	-	643.8	696.7	723.1	
164.0	64.4	100.8*	-	-	-	100.4	65.6	282.2	637.1*	-	-	643.8	692.3	718.7	
177.2	56.9	99.0*	-	-	-	98.3	72.2	257.9	617.3*	-	-	639.3	685.6	718.7	
190.3	50.3	97.0*	89.7	-	-	95.8	78.7	238.1	586.4*	-	-	630.5	681.2	714.3	
203.4	44.5	95.2*	89.7	-	-	93.3	85.3	220.5	562.2*	-	-	626.1	676.8	707.7	
216.5	39.2	93.3*	89.7	-	-	90.6	91.9	205.0	533.5*	-	-	619.5	674.6	694.5	
229.7	34.6	91.5*	89.5	-	-	88.2	98.4	180.8*	449.7*	590.8	-	593.0	643.8	643.8	
242.8	30.4	89.7*	89.1	-	-	85.6	111.5	-	-	518.1	-	516.6	562.9	562.9	
255.9	26.7	88.2*	88.4	-	-	83.1	124.7	-	-	463.0	-	451.9	493.1	493.1	
269.0	23.4	86.6*	88.0	71.0	-	80.6	134.5	-	-	427.7	-	412.3	449.0	449.0	
282.2	20.1	85.1*	87.5	71.0	-	78.3	137.8	-	-	-	-	399.0	434.3	434.3	
295.3	17.4	83.3*	86.9	71.0	-	75.8	144.4	-	-	-	374.8	-	377.0	411.5	412.3
308.4	14.8	75.0*	86.6	71.0	-	73.6	150.9	-	-	-	357.1	-	354.9	388.7	390.2
321.5	12.6	64.6*	86.2	71.0	-	71.4	164.0	-	-	-	324.1	-	316.0	349.1	350.5
324.8	9.3*	61.9*	85.9	71.0	-	70.9	167.3	-	-	-	315.3	-	307.5	340.6	341.7
334.6	-	-	84.9	71.0	-	69.2	177.2	-	-	-	-	-	282.2	315.3	315.3
337.9	-	-	82.4	71.0	58.0	68.7	183.7	-	-	-	-	269.0	269.7	301.3	301.3
347.8	-	-	75.0	71.0	58.0	67.3	190.3	-	-	-	-	257.9	257.2	287.3	287.3
357.6	-	-	67.0	71.0	58.0	65.9	196.9	-	-	-	-	249.1	244.7	273.4	273.4
360.9	-	-	-	71.0	58.0	65.5	203.4	-	-	-	-	-	233.7	262.4	262.4
374.0	-	-	-	71.0	58.0	63.9	216.5	-	-	-	-	-	212.7	240.3	240.3
387.1	-	-	-	71.0	58.0	62.3	229.7	-	-	-	-	-	190.7	210.2	210.2
400.3	-	-	-	-	58.0	60.8	242.8	-	-	-	-	-	166.4	186.3	184.1
413.4	-	-	-	-	58.0	59.5	252.6	-	-	-	-	-	153.2	167.6	166.4
426.5	-	-	-	-	-	55.3									
439.6	-	-	-	-	-	48.1									
452.8	-	-	-	-	-	39.5									
465.9	-	-	-	-	-	33.1									

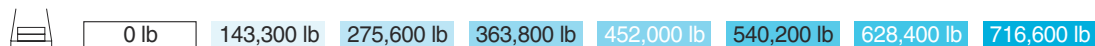

SWSL_1: 36.1 ft – 62.3 ft

SWSL_3/SFSL_3, SWSL_4/SFSL_4: 36.1 ft – 68.9 ft

SFSL_3 + SFSL_4: 496,100 lb + 110,200 lb

* Main boom angle 85°

Main boom angle 87°, 85°, 75°, 65° and 55°, capacities for intermediate boom positions are calculated by the crane control system IC-1

Operation

SWSL, SFSL

363,800 lb + 110,200 lb 36.1-68.9 ft 27.6 ft 32.2 ft/s 360° ASME B30.5										
196.9 ft + 118.1 ft					196.9 ft + 157.5 ft					
SWSL_1					SFSL_1	SFSL_3	SFSL_4			
0 lb					0 lb - 716,600 lb					
87°/85° 87°/85° 75° 65° 55°					15° 15° 15°					
ft	1,000 lb									
49.2	339.5	478.4	-	-	-	-	-	-	-	
52.5	319.7	476.2	-	-	-	-	-	-	-	
59.1	288.8	489.4*	-	-	-	-	-	-	-	
65.6	262.4	485.0*	-	-	-	-	-	-	-	
68.9	251.3	481.7*	-	-	-	467.4	-	-	-	
72.2	240.3	478.4*	-	-	-	467.4	-	-	-	
75.5	230.4	474.0*	-	-	-	467.4	520.3	535.7	-	
78.7	220.5	469.6*	-	-	-	467.4	520.3	535.7	-	
85.3	205.0	458.6*	-	-	-	467.4	513.7	531.3	-	
91.9	190.7	447.5*	-	-	-	467.4	513.7	526.9	-	
98.4	177.5	436.5*	-	-	-	465.2	509.3	526.9	-	
111.5	155.4	410.1*	-	-	-	458.6	500.4	520.3	-	
114.8	149.9	393.0*	467.4	-	-	458.6	500.4	520.3	-	
124.7	133.4	341.7*	456.4	-	-	440.2	480.6	493.8	-	
131.2	124.6	304.2*	433.2	-	-	421.8	460.8	467.4	-	
137.8	112.4*	266.8*	410.1	-	-	403.4	440.9	440.9	-	
150.9	-	-	370.4	-	-	359.4	396.8	395.4	-	
164.0	-	-	330.7	-	-	320.4	356.4	354.9	-	
167.3	-	-	312.0	310.9	-	312.0	347.2	346.1	-	
170.6	-	-	293.2	302.0	-	303.5	338.0	337.3	-	
177.2	-	-	-	288.8	-	286.6	319.7	319.7	-	
190.3	-	-	-	266.8	-	260.1	293.2	291.7	-	
203.4	-	-	-	246.9	-	236.6	268.2	266.8	-	
213.3	-	-	-	-	220.5	221.2	250.6	250.2	-	
216.5	-	-	-	-	216.1	216.1	244.7	244.7	-	
229.7	-	-	-	-	201.7	197.9	226.3	225.6	-	
232.9	-	-	-	-	198.4	193.7	221.7	220.8	-	
242.8	-	-	-	-	-	182.2	207.5	205.9	-	
255.9	-	-	-	-	-	167.6	186.3	185.2	-	
269.0	-	-	-	-	-	147.7	163.5	162.4	-	
282.2	-	-	-	-	-	129.0	145.1	144.0	-	
292.0	-	-	-	-	-	119.0	131.2	130.1	-	
59.1	266.8	352.7	-	-	-	-	-	-	-	
65.6	242.5	348.3	-	-	-	-	-	-	-	
72.2	222.7	357.1*	-	-	-	-	-	-	-	
78.7	205.0	354.9*	-	-	-	-	-	-	-	
82.0	197.3	352.7*	-	-	-	-	-	346.1	-	
85.3	189.6	350.5*	-	-	-	-	-	346.1	-	
88.6	183.0	349.4*	-	-	-	-	-	346.1	381.4	
91.9	176.4	348.3*	-	-	-	-	-	346.1	381.4	
98.4	164.2	343.9*	-	-	-	-	-	346.1	381.4	
111.5	144.4	332.9*	-	-	-	-	-	346.1	379.2	
124.7	127.9	321.9*	-	-	-	-	-	341.7	374.8	
131.2	120.7	315.3*	337.3	-	-	-	-	341.7	374.8	
137.8	113.5	308.6*	335.1	-	-	-	-	341.7	374.8	
150.9	100.3	269.0*	335.1	-	-	-	-	334.4	368.9	
164.0	89.1	229.3*	330.7	-	-	-	-	318.9	354.2	
170.6	84.2	207.8*	316.4	-	-	-	-	305.0	340.2	
177.2	76.1*	186.3*	302.0	-	-	-	-	291.0	326.3	
187.0	-	-	273.9	266.8	-	-	-	270.1	304.2	
190.3	-	-	264.6	260.1	-	-	-	263.1	296.9	
203.4	-	-	224.9	240.3	-	-	-	238.8	270.4	
210.0	-	-	205.0	231.5	-	-	-	228.5	258.7	
216.5	-	-	-	222.7	-	-	-	218.3	246.9	
229.7	-	-	-	208.3	-	-	-	199.9	229.3	
239.5	-	-	-	198.4	186.3	-	-	188.1	216.4	
242.8	-	-	-	195.1	183.0	-	-	184.5	212.4	
255.9	-	-	-	-	172.0	-	-	169.8	196.2	
269.0	-	-	-	-	162.0	-	-	156.5	181.2	
272.3	-	-	-	-	159.8	-	-	153.2	177.7	
282.2	-	-	-	-	-	-	-	143.7	164.6	
295.3	-	-	-	-	-	-	-	131.2	145.5	
308.4	-	-	-	-	-	-	-	114.6	129.0	
321.5	-	-	-	-	-	-	-	101.5	114.5	
331.4	-	-	-	-	-	-	-	91.9	102.7	

0 lb 143,300 lb 275,600 lb 363,800 lb 452,000 lb 540,200 lb 628,400 lb 716,600 lb

SWSL_1: 36.1 ft – 62.3 ft

SWSL_3/SFSL_3, SWSL_4/SFSL_4: 36.1 ft – 68.9 ft

SFSL_3 + SFSL_4: 496,100 lb + 110,200 lb

* Main boom angle 85°

Main boom angle 87°, 85°, 75°, 65° and 55°, capacities for intermediate boom positions are calculated by the crane control system IC-1

Operation

SWSL, SFSL

363,800 lb + 110,200 lb 36.1-68.9 ft 27.6 ft 32.2 ft/s 360° ASME B30.5										
196.9 ft + 196.9 ft					196.9 ft + 236.2 ft					
SWSL_1					SWSL_1					
0 lb					0 lb - 716,600 lb					
87°/85° 87°/85° 75° 65° 55°					15° 15° 15°					
ft	1,000 lb				ft	1,000 lb				
65.6	227.1	262.4	-	-	-	75.5	185.2	195.1	-	-
72.2	207.2	260.1	-	-	-	78.7	177.5	195.1	-	-
78.7	190.7	257.9	-	-	-	85.3	164.2	194.0	-	-
85.3	176.4	262.4*	-	-	-	91.9	152.1	195.1*	-	-
91.9	164.2	262.4*	-	-	-	98.4	141.1	194.0*	-	-
98.4	153.2	260.1*	-	-	257.9	111.5	123.5	192.9*	-	-
105.0	143.3	257.9*	-	-	257.9	124.7	109.1	190.7*	190.7	207.2
111.5	133.4	255.7*	-	-	257.9	137.8	96.8	187.4*	190.7	206.1
124.7	117.9	251.3*	-	-	257.2	150.9	86.4	184.1*	187.0	203.2
137.8	105.8	244.7*	-	-	255.7	164.0	77.4	180.8*	180.8	202.1
147.6	97.6	239.8*	238.1	-	253.5	177.2	69.7	176.4*	172.0	196.2
150.9	94.8	238.1*	238.1	-	252.8	190.3	62.8	173.1*	172.0	192.9
164.0	85.5	231.5*	238.1	-	249.1	203.4	56.9	169.8*	172.0	186.3
177.2	76.7	211.6*	238.1	-	244.7	216.5	51.8	153.2*	172.0	181.9
190.3	68.8	184.1*	238.1	-	236.6	229.7	46.7	135.6*	172.0	179.7
203.4	61.9	157.6*	238.1	-	229.3	242.8	41.9	116.8*	172.0	174.9
206.7	60.4	151.0*	231.2	-	227.1	246.1	40.8	112.1*	167.6	173.6
210.0	55.5*	144.4*	224.3	206.1	224.9	252.6	35.3*	102.7*	158.7	171.0
213.3	54.0*	137.8*	217.4	206.1	222.7	255.9	-	154.3	142.2	169.8
216.5	-	-	210.5	206.1	220.5	269.0	-	-	136.7	166.4
229.7	-	-	184.1	203.9	202.8	282.2	-	-	119.0	159.8
242.8	-	-	158.7	190.7	186.3	285.4	-	-	114.6	157.6
249.3	-	-	145.5	184.1	178.6	295.3	-	-	142.2	151.0
255.9	-	-	-	178.6	170.9	308.4	-	-	135.6	141.5
265.7	-	-	-	170.3	159.8	318.2	-	-	122.4	134.3
269.0	-	-	-	167.6	157.6	321.5	-	-	120.2	131.9
282.2	-	-	-	155.4	147.7	334.6	-	-	114.6	122.4
295.3	-	-	-	-	140.0	347.8	-	-	108.9	112.5
308.4	-	-	-	-	132.3	360.9	-	-	-	100.5
311.7	-	-	-	-	130.1	374.0	-	-	-	88.2
321.5	-	-	-	-	114.8	387.1	-	-	-	78.3
334.6	-	-	-	-	101.9	400.3	-	-	-	68.1
347.8	-	-	-	-	89.3	406.8	-	-	-	62.2
360.9	-	-	-	-	79.4					
367.5	-	-	-	-	73.2					

0 lb 143,300 lb 275,600 lb 363,800 lb 452,000 lb 540,200 lb 628,400 lb 716,600 lb

SWSL_1: 36.1 ft – 62.3 ft

SWSL_3/SFSL_3, SWSL_4/SFSL_4: 36.1 ft – 68.9 ft

SFSL_3 + SFSL_4: 496,100 lb + 110,200 lb

* Main boom angle 85°

Main boom angle 87°, 85°, 75°, 65° and 55°, capacities for intermediate boom positions are calculated by the crane control system IC-1

Operation

SWSL, SFSL

363,800 lb + 110,200 lb 36.1-68.9 ft 27.6 ft 32.2 ft/s 360° ASME B30.5									
196.9 ft + 275.6 ft					196.9 ft + 315.0 ft				
SWSL_1					SWSL_1				
0 lb					0 lb - 716,600 lb				
87°/85° 87°/85° 75° 65° 55°					87°/85° 87°/85° 75° 65° 55°				
15° 15° 15°					15° 15° 15°				
ft	1,000 lb								
85.3	140.0	143.3	-	-	-	-	-	-	-
91.9	138.9	142.2	-	-	-	-	-	-	-
98.4	130.1	141.1	-	-	-	-	-	-	-
111.5	113.5	140.0*	-	-	-	-	-	-	-
124.7	99.6	138.9*	-	-	-	137.8	147.7	149.9	-
137.8	88.0	136.7*	-	-	-	136.7	146.6	147.7	-
150.9	77.8	135.6*	-	-	-	135.2	144.4	145.5	-
164.0	69.2	133.4*	-	-	-	133.0	141.8	142.9	-
177.2	61.7	131.2*	-	-	-	130.1	138.9	140.0	-
180.4	60.1	130.6*	121.3	-	-	129.5	138.2	139.3	-
190.3	55.1	129.0*	121.3	-	-	127.9	136.0	137.1	-
203.4	49.4	125.7*	121.3	-	-	124.9	133.0	134.1	-
216.5	44.3	124.6*	121.3	-	-	121.3	130.1	131.2	-
229.7	39.7	122.4*	121.3	-	-	118.5	126.4	127.5	-
242.8	35.5	120.2*	121.3	-	-	115.4	122.7	123.8	-
252.6	32.7	115.2*	121.3	99.4	-	113.2	120.0	121.1	-
255.9	31.7	113.5*	121.3	99.4	-	112.4	119.0	120.2	-
269.0	28.4	100.1*	121.3	99.4	-	109.8	116.3	116.4	-
282.2	25.4	86.9*	121.3	99.4	-	106.9	112.9	113.1	-
288.7	20.7*	79.6*	118.5	99.4	-	105.5	111.1	111.6	-
295.3	-	-	115.7	99.4	-	104.1	109.3	110.0	-
308.4	-	-	102.7	99.4	-	101.0	105.7	106.0	-
321.5	-	-	89.3	99.4	83.6	98.3	102.4	102.7	-
324.8	-	-	85.8	99.4	83.6	97.7	101.6	102.0	-
334.6	-	-	-	99.4	83.6	95.7	99.2	99.6	-
347.8	-	-	-	99.4	83.6	93.1	96.0	96.5	-
357.6	-	-	-	92.8	83.6	90.9	93.8	94.2	-
360.9	-	-	-	-	83.6	89.9	93.0	93.5	-
374.0	-	-	-	-	83.6	85.8	89.7	90.4	-
387.1	-	-	-	-	83.6	76.7	83.8	84.4	-
400.3	-	-	-	-	-	67.1	76.4	76.4	-
413.4	-	-	-	-	-	57.8	67.2	66.4	-
426.5	-	-	-	-	-	50.7	59.7	58.7	-
439.6	-	-	-	-	-	42.3	50.7	49.8	-
442.9	-	-	-	-	-	39.9	48.1	47.2	-
95.1	102.5	104.7	-	-	-	-	-	-	-
98.4	102.3	104.3	-	-	-	-	-	-	-
111.5	100.3	102.7*	-	-	-	-	-	-	-
124.7	90.8	101.4*	-	-	-	-	-	-	-
137.8	79.4	99.9*	-	-	-	99.4	105.6	106.5	-
150.9	69.9	98.3*	-	-	-	98.1	103.9	104.6	-
164.0	61.5	96.8*	-	-	-	96.5	102.1	102.6	-
177.2	54.2	95.0*	-	-	-	94.6	100.1	100.5	-
190.3	47.8	93.3*	-	-	-	92.4	97.7	98.3	-
196.9	45.0	92.4*	85.3	-	-	91.3	96.6	97.2	-
203.4	42.1	91.5*	85.3	-	-	90.1	95.3	96.0	-
216.5	37.3	89.7*	85.3	-	-	87.7	92.8	93.7	-
229.7	32.6	88.0*	85.3	-	-	85.4	90.3	91.1	-
242.8	28.7	86.4*	85.3	-	-	83.0	87.7	88.4	-
255.9	24.9	84.9*	85.1	-	-	80.5	85.1	85.8	-
269.0	21.6	83.3*	84.7	-	-	78.3	82.5	83.0	-
275.6	20.1	82.6*	84.5	67.0	-	77.2	81.1	81.6	-
282.2	18.5	81.8*	84.4	67.0	-	76.0	79.7	80.2	-
295.3	15.7	80.2*	84.0	67.0	-	73.9	76.9	77.4	-
308.4	13.2	73.9*	83.8	67.0	-	71.7	74.1	74.6	-
321.5	11.0	63.5*	83.6	67.0	-	69.5	71.4	71.8	-
328.1	-	57.8*	83.2	67.0	-	68.5	70.0	70.4	-
334.6	-	-	83.1	67.0	-	67.5	68.6	69.0	-
347.8	-	-	76.7	67.0	54.2	65.6	66.4	66.8	-
360.9	-	-	66.1	67.0	54.2	63.7	64.2	64.6	-
374.0	-	-	-	67.0	54.2	61.9	61.9	62.4	-
387.1	-	-	-	67.0	54.2	60.5	59.9	60.4	-
393.7	-	-	-	67.0	54.2	59.7	58.9	59.3	-
400.3	-	-	-	-	54.2	59.0	57.7	58.0	-
413.4	-	-	-	-	54.2	57.5	55.3	55.6	-
423.2	-	-	-	-	54.2	55.6	52.7	53.0	-
426.5	-	-	-	-	-	54.9	52.0	52.2	-
439.6	-	-	-	-	-	48.1	49.0	48.9	-
452.8	-	-	-	-	-	42.3	46.1	45.6	-
465.9	-	-	-	-	-	34.8	39.2	38.7	-
479.0	-	-	-	-	-	26.8	34.3	33.1	-
482.3	-	-	-	-	-	24.7	32.2	31.3	-

0 lb 143,300 lb 275,600 lb 363,800 lb 452,000 lb 540,200 lb 628,400 lb 716,600 lb

SWSL_1: 36.1 ft – 62.3 ft

SWSL_3/SFSL_3, SWSL_4/SFSL_4: 36.1 ft – 68.9 ft

SFSL_3 + SFSL_4: 496,100 lb + 110,200 lb

* Main boom angle 85°

Main boom angle 87°, 85°, 75°, 65° and 55°, capacities for intermediate boom positions are calculated by the crane control system IC-1

Operation

SWSL, SFSL

363,800 lb + 110,200 lb 36.1-68.9 ft 27.6 ft 32.2 ft/s 360° ASME B30.5										
216.5 ft + 78.7 ft					216.5 ft + 118.1 ft					
SWSL_1					SFSL_1	SFSL_3	SFSL_4			
0 lb					0 lb - 716,600 lb					
87°/85° 87°/85° 75° 65° 55°					15° 15° 15°					
ft	1,000 lb									
42.7	396.8	568.8	-	-	-	-	-	-	-	
45.9	372.6	562.2	-	-	-	-	-	-	-	
52.5	332.9	588.6*	-	-	-	-	-	-	-	
59.1	299.8	575.4*	-	-	-	562.2	-	659.2	-	
62.3	284.4	568.8*	-	-	-	562.2	630.5	659.2	-	
65.6	271.2	562.2*	-	-	-	562.2	630.5	659.2	-	
72.2	249.1	544.5*	-	-	-	562.2	623.9	654.8	-	
78.7	229.3	529.1*	-	-	-	555.6	619.5	654.8	-	
85.3	213.8	511.5*	-	-	-	555.6	615.1	650.4	-	
91.9	199.5	493.8*	-	-	-	551.2	610.7	646.0	-	
95.1	194.0	479.5*	-	-	-	544.5	608.5	642.6	-	
98.4	178.6*	471.8*	-	-	-	544.5	608.5	641.5	-	
101.7	172.0*	432.1*	-	-	-	531.3	593.4	621.0	-	
105.0	-	-	546.7	-	-	520.3	578.3	600.4	-	
111.5	-	-	513.7	-	-	498.2	548.2	559.2	-	
124.7	-	-	458.6	-	-	449.7	489.4	489.4	-	
137.8	-	-	412.3	-	-	396.8	432.1	432.1	-	
150.9	-	-	-	-	-	352.7	386.5	388.0	-	
154.2	-	-	-	341.7	-	341.7	375.2	377.0	-	
164.0	-	-	-	317.5	-	314.5	346.9	348.3	-	
173.9	-	-	-	297.6	-	290.3	321.5	321.9	-	
177.2	-	-	-	-	-	282.2	313.1	313.1	-	
190.3	-	-	-	-	-	255.7	285.1	285.1	-	
196.9	-	-	-	-	242.5	242.5	271.2	271.2	-	
203.4	-	-	-	-	233.7	231.5	259.4	259.4	-	
206.7	-	-	-	-	229.3	226.0	253.5	253.5	-	
216.5	-	-	-	-	-	210.5	235.9	235.9	-	
229.7	-	-	-	-	-	192.9	217.5	217.5	-	
242.8	-	-	-	-	-	174.9	195.5	195.5	-	
255.9	-	-	-	-	-	156.5	169.8	169.8	-	
269.0	-	-	-	-	-	136.2	150.4	149.0	-	
272.3	-	-	-	-	-	133.4	145.5	144.4	-	

27.6 ft 32.2 ft/s 360° ASME B30.5										
216.5 ft + 78.7 ft					216.5 ft + 118.1 ft					
SWSL_1					SFSL_1	SFSL_3	SFSL_4			
0 lb					0 lb - 716,600 lb					
87°/85° 87°/85° 75° 65° 55°					15° 15° 15°					
ft	1,000 lb									
49.2	324.1	425.5	-	-	-	-	-	-	-	
52.5	308.6	421.1	-	-	-	-	-	-	-	
59.1	277.8	414.5	-	-	-	-	-	-	-	
65.6	251.3	429.9*	-	-	-	-	-	-	-	
72.2	231.5	423.3*	-	-	-	-	-	414.5	-	
78.7	213.8	416.7*	-	-	-	-	-	414.5	471.8	
85.3	198.4	407.9*	-	-	-	-	-	414.5	471.8	
91.9	184.1	399.0*	-	-	-	-	-	414.5	465.2	
98.4	172.0	388.0*	-	-	-	-	-	414.5	465.2	
111.5	152.1	368.2*	-	-	-	-	-	410.1	458.6	
118.1	142.7	359.4*	412.3	-	-	-	-	410.1	458.6	
124.7	133.4	350.5*	412.3	-	-	-	-	402.7	448.3	
131.2	124.6	315.3*	407.9	-	-	-	-	402.0	442.4	
137.8	111.3*	280.0*	405.7	-	-	-	-	401.2	436.5	
141.1	108.5*	260.1*	396.3	-	-	-	-	390.6	425.5	
150.9	-	-	368.2	-	-	-	-	358.6	392.4	
164.0	-	-	332.9	-	-	-	-	320.4	352.7	
177.2	-	-	288.8	284.4	-	-	-	286.6	317.5	
190.3	-	-	-	262.4	-	-	-	258.7	289.5	
203.4	-	-	-	242.5	-	-	-	234.4	263.8	
213.3	-	-	-	229.3	-	-	-	219.0	246.2	
216.5	-	-	-	-	-	-	-	213.8	240.3	
223.1	-	-	-	-	-	-	203.9	205.0	231.1	
229.7	-	-	-	-	-	-	197.3	196.2	221.9	
242.8	-	-	-	-	-	-	184.1	180.0	203.9	
246.1	-	-	-	-	-	-	181.9	176.4	200.1	
255.9	-	-	-	-	-	-	-	165.3	188.5	
269.0	-	-	-	-	-	-	-	152.9	170.9	
282.2	-	-	-	-	-	-	-	138.2	152.1	
295.3	-	-	-	-	-	-	-	121.3	133.4	
308.4	-	-	-	-	-	-	-	108.5	119.0	

0 lb 143,300 lb 275,600 lb 363,800 lb 452,000 lb 540,200 lb 628,400 lb 716,600 lb

SWSL_1: 36.1 ft – 62.3 ft

SWSL_3/SFSL_3, SWSL_4/SFSL_4: 36.1 ft – 68.9 ft

SFSL_3 + SFSL_4: 496,100 lb + 110,200 lb

* Main boom angle 85°

Main boom angle 87°, 85°, 75°, 65° and 55°, capacities for intermediate boom positions are calculated by the crane control system IC-1

Operation

SWSL, SFSL

363,800 lb + 110,200 lb 36.1-68.9 ft										27.6 ft 32.2 ft/s 360° ASME B30.5									
216.5 ft + 157.5 ft										216.5 ft + 196.9 ft									
SWSL_1					SFSL_1	SFSL_3	SFSL_4	SWSL_1					SFSL_1	SFSL_3	SFSL_4				
0 lb					0 lb - 716,600 lb					0 lb					0 lb - 716,600 lb				
87°/85° 87°/85° 75° 65° 55°					15° 15° 15°					87°/85° 87°/85° 75° 65° 55°					15° 15° 15°				
ft										ft									
1,000 lb										1,000 lb									
59.1	257.9	315.3	-	-	-	-	-	-	-	68.9	208.3	235.9	-	-	-	-	-	-	-
65.6	233.7	313.1	-	-	-	-	-	-	-	72.2	199.5	235.9	-	-	-	-	-	-	-
72.2	215.0	319.7*	-	-	-	-	-	-	-	78.7	184.1	233.7	-	-	-	-	-	-	-
78.7	198.4	317.5*	-	-	-	-	-	-	-	85.3	170.9	238.1*	-	-	-	-	-	-	-
85.3	183.0	315.3	-	-	-	-	308.6	-	359.4	91.9	158.7	235.9*	-	-	-	-	-	-	-
91.9	170.9	310.9*	-	-	-	-	308.6	350.5	359.4	98.4	147.7	233.7*	-	-	-	231.5	260.1	266.8	-
98.4	158.7	306.4*	-	-	-	-	308.6	350.5	359.4	111.5	129.0	231.5*	-	-	-	231.5	260.1	266.8	-
111.5	140.0	297.6*	-	-	-	-	308.6	350.5	359.4	124.7	114.6	224.9*	-	-	-	230.8	260.1	266.8	-
124.7	124.6	286.6*	-	-	-	-	306.4	346.1	355.7	137.8	102.3	220.5*	-	-	-	229.3	260.1	266.8	-
134.5	114.6	278.3*	299.8	-	-	-	306.4	346.1	354.9	150.9	91.7	215.0*	218.3	-	-	229.3	258.7	263.8	-
137.8	111.3	275.6*	299.8	-	-	-	306.4	346.1	354.9	164.0	82.9	208.3*	218.3	-	-	227.1	255.0	259.4	-
150.9	100.5	264.6*	299.8	-	-	-	301.3	339.5	347.6	177.2	75.2	201.7*	218.3	-	-	222.7	249.1	253.5	-
164.0	89.3	235.9*	299.8	-	-	-	294.7	333.6	337.3	190.3	68.3	189.6*	218.3	-	-	216.8	243.2	246.2	-
170.6	84.4	215.5*	296.5	-	-	-	291.7	327.8	328.5	203.4	61.7	163.1*	217.2	-	-	211.6	235.9	238.1	-
177.2	75.6*	195.1*	295.4	-	-	-	288.8	321.9	319.7	206.7	60.2	156.3*	216.9	-	-	210.5	233.7	235.9	-
190.3	-	-	275.6	-	-	-	262.4	293.9	291.7	216.5	52.0*	135.6*	216.1	187.4	-	207.2	227.1	229.3	-
196.9	-	-	260.1	246.9	-	-	249.1	280.0	277.8	229.7	-	-	196.2	187.4	-	199.9	217.5	219.7	-
203.4	-	-	244.7	238.1	-	-	238.5	268.2	266.0	242.8	-	-	170.9	187.4	-	184.5	206.6	207.5	-
216.5	-	-	202.8	220.5	-	-	217.2	244.7	242.5	252.6	-	-	151.0	178.3	-	173.4	197.3	196.2	-
229.7	-	-	-	205.0	-	-	198.4	226.3	224.9	255.9	-	-	-	175.3	-	169.8	194.0	192.9	-
242.8	-	-	-	191.8	-	-	182.2	208.3	207.2	269.0	-	-	-	164.2	-	156.5	180.0	178.9	-
249.3	-	-	-	186.3	-	-	174.9	199.5	199.2	278.9	-	-	-	157.6	145.5	147.2	169.9	168.8	-
252.6	-	-	-	-	170.9	-	171.2	195.7	195.5	282.2	-	-	-	155.4	143.3	144.4	166.8	165.7	-
255.9	-	-	-	-	167.6	167.6	167.6	191.8	191.8	288.7	-	-	-	151.0	139.3	138.9	160.6	159.5	-
269.0	-	-	-	-	157.6	155.1	177.8	177.8	177.8	295.3	-	-	-	-	135.6	133.4	154.3	153.2	-
282.2	-	-	-	-	148.8	143.3	164.6	164.2	164.2	308.4	-	-	-	-	127.9	123.5	144.0	142.9	-
295.3	-	-	-	-	-	132.3	152.1	151.0	151.0	321.5	-	-	-	-	121.3	114.7	132.3	131.5	-
308.4	-	-	-	-	-	121.3	135.2	134.1	134.1	334.6	-	-	-	-	-	106.0	119.0	119.0	-
321.5	-	-	-	-	-	108.4	119.0	117.9	117.9	347.8	-	-	-	-	-	94.6	106.0	105.2	-
334.6	-	-	-	-	-	93.7	105.8	104.5	104.5	360.9	-	-	-	-	-	82.7	92.7	91.6	-
347.8	-	-	-	-	-	83.8	92.4	91.5	91.5	374.0	-	-	-	-	-	72.8	82.2	80.9	-
										383.9	-	-	-	-	-	65.9	74.1	73.0	-

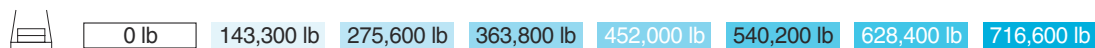

SWSL_1: 36.1 ft – 62.3 ft

SWSL_3/SFSL_3, SWSL_4/SFSL_4: 36.1 ft – 68.9 ft

SFSL_3 + SFSL_4: 496,100 lb + 110,200 lb

* Main boom angle 85°

Main boom angle 87°, 85°, 75°, 65° and 55°, capacities for intermediate boom positions are calculated by the crane control system IC-1

Operation

SWSL, SFSL

363,800 lb + 110,200 lb 36.1-68.9 ft 27.6 ft 32.2 ft/s 360° ASME B30.5										
216.5 ft + 236.2 ft					216.5 ft + 275.6 ft					
SWSL_1					SFSL_1	SFSL_3	SFSL_4			
0 lb					0 lb - 716,600 lb					
87°/85° 87°/85° 75° 65° 55°					15° 15° 15°					
ft	1,000 lb									
78.7	170.9	177.5	-	-	-	-	-	-	-	
85.3	157.6	176.4	-	-	-	-	-	-	-	
91.9	146.6	178.6*	-	-	-	-	-	-	-	
98.4	136.7	177.5*	-	-	-	-	-	-	-	
111.5	119.0	176.4*	-	-	-	174.2	194.0	197.3	-	
124.7	105.4	174.2*	-	-	-	174.2	194.0	197.3	-	
137.8	93.5	170.9*	-	-	-	174.2	194.0	197.3	-	
150.9	83.3	167.6*	-	-	-	172.0	191.8	194.4	-	
164.0	74.7	164.2*	-	-	-	169.8	189.2	191.4	-	
167.3	72.9	163.4*	155.4	-	-	169.2	188.5	190.7	-	
177.2	67.2	160.9*	155.4	-	-	167.6	186.3	188.5	-	
190.3	60.6	157.6*	155.4	-	-	163.9	182.6	184.1	-	
203.4	54.7	153.2*	155.4	-	-	160.2	177.8	180.0	-	
216.5	49.6	149.9*	155.4	-	-	156.5	174.2	176.4	-	
229.7	45.2	137.8*	155.4	-	-	152.7	169.4	171.6	-	
239.5	42.2	124.6*	155.4	131.2	-	150.1	166.6	168.7	-	
242.8	41.2	120.2*	155.4	131.2	-	149.2	165.7	167.6	-	
246.1	40.1	115.4*	155.4	131.2	-	148.3	164.8	166.4	-	
252.6	34.4*	106.0*	155.4	131.2	-	146.4	163.0	164.2	-	
255.9	-	-	155.4	131.2	-	145.5	162.0	163.1	-	
269.0	-	-	144.4	131.2	-	140.7	158.4	159.5	-	
282.2	-	-	126.8	131.2	-	137.1	152.9	154.7	-	
292.0	-	-	112.4	131.2	-	134.3	149.0	150.3	-	
295.3	-	-	-	131.2	-	133.4	147.7	148.8	-	
305.1	-	-	-	131.2	112.4	126.8	141.1	141.6	-	
308.4	-	-	-	131.2	112.4	124.6	138.9	139.3	-	
321.5	-	-	-	126.8	112.4	114.8	130.1	130.1	-	
328.1	-	-	-	120.2	111.2	110.5	125.7	125.7	-	
334.6	-	-	-	-	110.0	106.3	121.3	121.3	-	
347.8	-	-	-	-	104.3	98.2	112.9	112.3	-	
360.9	-	-	-	-	99.0	90.2	103.8	102.8	-	
374.0	-	-	-	-	-	82.2	93.7	92.8	-	
387.1	-	-	-	-	-	71.9	82.4	81.5	-	
400.3	-	-	-	-	-	61.6	71.1	70.2	-	
413.4	-	-	-	-	-	55.3	63.1	61.7	-	
423.2	-	-	-	-	-	47.4	55.6	54.7	-	
85.3	129.0	132.3	-	-	-	-	-	-	-	
91.9	129.0	131.2	-	-	-	-	-	-	-	
98.4	125.7	130.1	-	-	-	-	-	-	-	
111.5	109.6	130.1*	-	-	-	-	-	-	-	
124.7	95.9	129.0*	-	-	-	127.9	141.1	143.3	-	
137.8	84.4	127.9*	-	-	-	126.8	140.0	142.2	-	
150.9	74.7	125.7*	-	-	-	126.0	138.5	140.7	-	
164.0	66.6	123.5*	-	-	-	124.6	136.3	138.5	-	
177.2	59.3	121.3*	-	-	-	122.4	133.4	135.6	-	
183.7	56.1	120.2*	111.3	-	-	121.3	132.3	134.1	-	
190.3	52.9	119.0*	111.3	-	-	120.2	131.2	132.6	-	
203.4	47.2	116.8*	111.3	-	-	117.6	128.6	129.7	-	
216.5	42.1	114.6*	111.3	-	-	114.6	125.7	126.8	-	
229.7	37.7	112.4*	111.3	-	-	111.7	122.7	123.1	-	
242.8	33.7	110.2*	111.3	-	-	109.1	118.8	119.9	-	
255.9	30.0	108.7*	111.3	-	-	106.7	115.7	116.8	-	
262.5	28.3	105.5*	111.3	91.9	-	105.2	114.0	113.9	-	
269.0	26.7	102.3*	111.3	91.9	-	103.8	112.7	112.1	-	
282.2	23.8	89.1*	111.3	91.9	-	101.2	110.2	108.8	-	
285.4	23.1	85.5*	111.3	91.9	-	100.3	109.7	108.0	-	
292.0	18.3*	78.3*	111.3	91.9	-	99.0	108.6	106.6	-	
295.3	-	-	111.3	91.9	-	98.3	108.0	105.8	-	
308.4	-	-	108.0	91.9	-	95.5	105.5	102.1	-	
321.5	-	-	95.0	91.9	-	93.0	101.9	98.5	-	
328.1	-	-	88.2	91.9	-	91.8	99.5	97.1	-	
334.6	-	-	-	91.9	76.9	90.6	97.2	95.7	-	
347.8	-	-	-	91.7	76.7	88.2	92.7	92.7	-	
360.9	-	-	-	91.7	76.7	85.7	90.0	89.9	-	
364.2	-	-	-	91.7	76.7	85.0	89.4	89.2	-	
374.0	-	-	-	-	76.7	82.9	87.5	87.1	-	
387.1	-	-	-	-	76.7	76.4	84.7	84.0	-	
397.0	-	-	-	-	76.7	71.1	81.5	80.7	-	
400.3	-	-	-	-	-	69.1	79.7	78.9	-	
413.4	-	-	-	-	-	60.8	71.2	70.3	-	
426.5	-	-	-	-	-	52.0	61.5	60.8	-	
439.6	-	-	-	-	-	44.8	51.8	51.1	-	
452.8	-	-	-	-	-	38.1	45.4	44.5	-	
462.6	-	-	-	-	-	31.3	38.6	37.9	-	

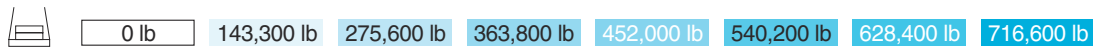

SWSL_1: 36.1 ft – 62.3 ft

SWSL_3/SFSL_3, SWSL_4/SFSL_4: 36.1 ft – 68.9 ft

SFSL_3 + SFSL_4: 496,100 lb + 110,200 lb

* Main boom angle 85°

Main boom angle 87°, 85°, 75°, 65° and 55°, capacities for intermediate boom positions are calculated by the crane control system IC-1

Operation

SWSL, SFSL

363,800 lb + 110,200 lb 36.1-68.9 ft 27.6 ft 32.2 ft/s 360° ASME B30.5										
216.5 ft + 315.0 ft					236.2 ft + 78.7 ft					
SWSL_1					SFSL_1	SFSL_3	SFSL_4			
0 lb					0 lb - 716,600 lb					
87°/85° 87°/85° 75° 65° 55°					15° 15° 15°					
ft	1,000 lb									
95.1	95.0	97.2	-	-	-	-	-	-	-	
98.4	94.8	96.8	-	-	-	-	-	-	-	
111.5	93.7	95.7*	-	-	-	-	-	-	-	
124.7	86.9	94.6*	-	-	-	-	-	-	-	
137.8	76.1	93.5*	-	-	-	92.8	100.1	101.2	-	
150.9	66.8	91.9*	-	-	-	91.8	98.8	99.5	-	
164.0	58.6	90.6*	-	-	-	90.5	97.3	98.0	-	
177.2	51.6	89.1*	-	-	-	89.1	95.7	96.3	-	
190.3	45.4	87.5*	-	-	-	87.2	93.8	94.3	-	
203.4	39.9	86.0*	78.9	-	-	85.2	91.9	92.3	-	
216.5	35.1	84.2*	78.9	-	-	83.1	89.9	90.4	-	
229.7	30.6	82.7*	78.9	-	-	80.9	87.6	88.2	-	
242.8	26.7	81.1*	78.9	-	-	78.8	85.2	85.9	-	
255.9	23.1	79.6*	78.9	-	-	76.7	82.9	83.6	-	
269.0	20.1	78.3*	78.9	-	-	74.5	80.4	81.1	-	
282.2	17.0	76.9*	78.9	-	-	72.5	77.8	78.3	-	
285.4	16.3	76.5*	78.9	61.7	-	72.0	77.2	77.6	-	
295.3	14.3	75.6*	78.9	61.7	-	70.5	75.2	75.6	-	
308.4	11.9	74.3*	78.7	61.7	-	68.5	72.5	73.0	-	
321.5	9.7	65.3*	78.7	61.7	-	66.4	69.7	70.1	-	
331.4	-	56.7*	78.7	61.7	-	65.0	67.7	68.1	-	
334.6	-	-	78.7	61.7	-	64.6	67.0	67.5	-	
347.8	-	-	78.7	61.7	-	62.6	64.8	65.1	-	
360.9	-	-	70.8	61.7	49.6	60.9	62.7	62.9	-	
367.5	-	-	65.3	61.7	49.6	60.1	61.6	61.9	-	
374.0	-	-	-	61.7	49.6	59.3	60.6	60.8	-	
387.1	-	-	-	61.7	49.6	57.6	58.6	58.8	-	
400.3	-	-	-	61.7	49.6	56.0	56.3	56.7	-	
403.5	-	-	-	61.7	49.6	55.6	55.8	56.2	-	
413.4	-	-	-	-	49.6	54.5	54.2	54.7	-	
426.5	-	-	-	-	49.6	53.1	51.7	51.9	-	
436.4	-	-	-	-	49.6	50.9	49.1	49.3	-	
439.6	-	-	-	-	-	49.2	48.1	48.3	-	
452.8	-	-	-	-	-	42.8	44.3	44.3	-	
465.9	-	-	-	-	-	35.1	40.5	40.2	-	
479.0	-	-	-	-	-	30.4	34.9	34.5	-	
492.1	-	-	-	-	-	23.1	29.1	28.4	-	
498.7	-	-	-	-	-	19.2	26.0	25.4	-	

27.6 ft 32.2 ft/s 360° ASME B30.5										
236.2 ft + 78.7 ft					216.5 ft + 315.0 ft					
SWSL_1					SFSL_1	SFSL_3	SFSL_4			
0 lb					0 lb - 716,600 lb					
87°/85° 87°/85° 75° 65° 55°					15° 15° 15°					
ft	1,000 lb									
42.7	379.2	511.5	-	-	-	-	-	-	-	
45.9	357.1	507.1	-	-	-	-	-	-	-	
52.5	317.5	529.1*	-	-	-	-	-	-	-	
59.1	286.6	520.3*	-	-	-	504.9	-	621.7	-	
65.6	262.4	507.1*	-	-	-	504.9	590.8	621.7	-	
72.2	240.3	491.6*	-	-	-	504.9	579.8	617.3	-	
78.7	222.7	478.4*	-	-	-	504.9	579.8	617.3	-	
85.3	206.1	463.0*	-	-	-	504.9	575.4	612.9	-	
91.9	192.9	447.5*	-	-	-	498.2	571.0	610.7	-	
95.1	187.4	440.9*	-	-	-	493.8	566.6	608.5	-	
98.4	170.9*	434.3*	-	-	-	493.8	566.6	608.5	-	
105.0	160.9*	412.3*	-	-	-	481.3	548.2	576.9	-	
108.3	-	-	502.7	-	-	479.5	540.1	561.1	-	
111.5	-	-	502.7	-	-	477.7	532.0	545.3	-	
124.7	-	-	451.9	-	-	446.8	486.5	484.3	-	
137.8	-	-	405.7	-	-	392.4	427.7	425.5	-	
144.4	-	-	388.0	-	-	371.1	405.7	403.4	-	
150.9	-	-	-	-	-	349.8	383.6	381.4	-	
160.8	-	-	-	319.7	-	320.0	352.7	350.5	-	
164.0	-	-	-	310.9	-	311.6	343.9	341.7	-	
177.2	-	-	-	284.4	-	277.8	308.6	306.4	-	
183.7	-	-	-	273.4	-	264.6	294.7	292.5	-	
190.3	-	-	-	-	-	251.3	280.7	278.5	-	
203.4	-	-	-	-	-	227.1	255.7	253.5	-	
206.7	-	-	-	-	222.7	222.1	250.2	248.0	-	
216.5	-	-	-	-	210.5	207.2	233.7	231.5	-	
219.8	-	-	-	-	207.2	202.8	228.9	226.0	-	
229.7	-	-	-	-	-	189.6	214.6	211.6	-	
242.8	-	-	-	-	-	173.8	196.9	194.4	-	
255.9	-	-	-	-	-	159.8	180.8	177.5	-	
269.0	-	-	-	-	-	142.2	158.0	154.7	-	
282.2	-	-	-	-	-	123.5	138.3	134.5	-	
288.7	-	-	-	-	-	115.7	130.1	126.8	-	

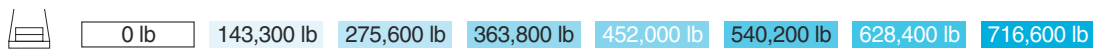

SWSL_1: 36.1 ft – 62.3 ft

SWSL_3/SFSL_3, SWSL_4/SFSL_4: 36.1 ft – 68.9 ft





































SFSL_3 + SFSL_4: 496,100 lb + 110,200 lb







* Main boom angle 85°

Main boom angle 87°, 85°, 75°, 65° and 55°, capacities for intermediate boom positions are calculated by the crane control system IC-1

Operation

SWSL, SFSL

 363,800 lb + 110,200 lb  36.1-68.9 ft  27.6 ft  32.2 ft/s  360°  ASME B30.5									
 236.2 ft + 118.1 ft					 236.2 ft + 157.5 ft				
 SWSL_1  SFSL_1  SFSL_3  SFSL_4					 SWSL_1  SFSL_1  SFSL_3  SFSL_4				
 0 lb  0 lb - 716,600 lb					 0 lb  0 lb - 716,600 lb				
 87°/85°  87°/85°  75°  65°  55°  15°  15°  15°					 87°/85°  87°/85°  75°  65°  55°  15°  15°  15°				
ft					ft				
1,000 lb					1,000 lb				
52.5	295.4	383.6	-	-	-	-	-	-	-
59.1	266.8	377.0	-	-	-	-	-	-	-
65.6	242.5	390.2*	-	-	-	-	-	-	-
72.2	222.7	383.6*	-	-	-	374.8	-	-	-
78.7	206.1	377.0*	-	-	-	374.8	443.1	467.4	-
85.3	190.7	370.4*	-	-	-	374.8	443.1	465.2	-
91.9	177.5	361.6*	-	-	-	374.8	440.9	463.0	-
98.4	166.4	352.7*	-	-	-	374.8	438.7	460.8	-
111.5	146.6	335.1*	-	-	-	372.6	432.1	456.4	-
124.7	131.2	317.5*	374.8	-	-	367.4	425.5	446.1	-
134.5	120.2	299.3*	371.5	-	-	366.3	425.5	433.9	-
137.8	111.3*	293.2*	370.4	-	-	366.0	425.5	429.9	-
141.1	107.8*	273.4*	366.0	-	-	359.0	415.6	418.9	-
150.9	-	-	359.4	-	-	344.7	385.8	385.8	-
164.0	-	-	328.5	-	-	317.5	349.1	346.9	-
177.2	-	-	299.8	-	-	282.2	315.3	313.1	-
183.7	-	-	282.2	266.8	-	269.0	301.3	299.1	-
190.3	-	-	-	255.7	-	255.7	287.3	285.1	-
203.4	-	-	-	238.1	-	231.5	261.6	259.4	-
216.5	-	-	-	220.5	-	211.6	238.1	235.9	-
219.8	-	-	-	217.2	-	207.2	233.5	231.3	-
229.7	-	-	-	-	-	194.0	219.7	217.4	-
236.2	-	-	-	-	185.2	185.2	210.5	208.3	-
242.8	-	-	-	-	178.6	177.5	202.5	200.3	-
255.9	-	-	-	-	167.6	162.0	186.3	184.1	-
269.0	-	-	-	-	-	149.5	172.3	170.1	-
282.2	-	-	-	-	-	137.8	157.3	154.7	-
295.3	-	-	-	-	-	127.9	141.1	137.8	-
308.4	-	-	-	-	-	111.7	122.7	120.2	-
321.5	-	-	-	-	-	95.8	109.7	105.9	-
324.8	-	-	-	-	-	93.7	106.7	103.2	-
59.1	246.9	288.8	-	-	-	-	-	-	-
65.6	224.9	286.6	-	-	-	-	-	-	-
72.2	206.1	282.2	-	-	-	-	-	-	-
78.7	190.7	291.0*	-	-	-	-	-	-	-
85.3	176.4	288.8*	-	-	-	-	-	-	-
88.6	170.3	286.6*	-	-	-	282.2	332.9	350.5	-
91.9	164.2	284.4*	-	-	-	282.2	332.9	350.5	-
98.4	153.2	280.0*	-	-	-	282.2	332.9	350.5	-
111.5	134.5	271.2*	-	-	-	282.2	332.9	350.5	-
124.7	120.2	262.4*	-	-	-	282.2	328.5	346.1	-
137.8	107.6	251.3*	-	-	-	282.2	328.5	346.1	-
141.1	105.0	248.6*	275.6	-	-	279.3	325.2	342.5	-
150.9	97.2	240.3*	275.6	-	-	277.0	324.1	338.8	-
164.0	88.4	231.5*	273.4	-	-	271.9	320.4	330.0	-
170.6	83.6	216.6*	272.3	-	-	270.4	318.9	322.6	-
177.2	74.3*	201.7*	271.2	-	-	269.0	317.5	315.3	-
180.4	72.3*	189.6*	267.9	-	-	264.9	310.5	308.3	-
190.3	-	-	264.6	-	-	252.8	289.5	287.3	-
203.4	-	-	251.3	-	-	234.1	263.8	261.6	-
206.7	-	-	243.6	227.1	-	228.7	257.9	255.7	-
216.5	-	-	220.5	215.0	-	212.7	240.3	238.1	-
219.8	-	-	209.4	211.3	-	208.3	235.5	233.3	-
229.7	-	-	-	199.5	-	195.1	221.2	219.0	-
242.8	-	-	-	187.4	-	178.9	203.3	201.4	-
255.9	-	-	-	175.3	-	164.2	187.4	185.2	-
259.2	-	-	-	173.1	-	160.9	183.9	181.7	-
262.5	-	-	-	-	156.5	157.6	180.4	178.2	-
269.0	-	-	-	-	151.0	151.0	173.4	171.2	-
282.2	-	-	-	-	143.3	139.1	160.6	158.4	-
295.3	-	-	-	-	135.6	129.0	148.8	146.6	-
308.4	-	-	-	-	-	118.7	137.1	134.8	-
321.5	-	-	-	-	-	108.5	124.2	121.6	-
334.6	-	-	-	-	-	98.5	109.3	106.9	-
347.8	-	-	-	-	-	84.9	95.3	92.2	-
360.9	-	-	-	-	-	73.9	84.4	81.7	-
364.2	-	-	-	-	-	72.1	81.4	78.9	-

SWSL_1:  **36.1 ft – 62.3 ft**

SWSL_3/SFSL_3, SWSL_4/SFSL_4:  **36.1 ft – 68.9 ft**

SFSL_3 + SFSL_4:  **496,100 lb + 110,200 lb**

* Main boom angle 85°

Main boom angle 87°, 85°, 75°, 65° and 55°, capacities for intermediate boom positions are calculated by the crane control system IC-1

Operation

SWSL, SFSL

363,800 lb + 110,200 lb 36.1-68.9 ft										27.6 ft 32.2 ft/s 360° ASME B30.5									
236.2 ft + 196.9 ft					236.2 ft + 236.2 ft														
SWSL_1					SFSL_1					SFSL_3					SFSL_4				
0 lb					0 lb - 716,600 lb					0 lb					0 lb - 716,600 lb				
87°/85° 87°/85° 75° 65° 55°					15° 15° 15°					87°/85° 87°/85° 75° 65° 55°					15° 15° 15°				
ft					1,000 lb					ft					1,000 lb				
68.9	200.6	219.4	-	-	-	-	-	-	-	78.7	160.9	165.3	-	-	-	-	-	-	-
72.2	191.8	218.3	-	-	-	-	-	-	-	85.3	152.1	164.2	-	-	-	-	-	-	-
78.7	177.5	216.1	-	-	-	-	-	-	-	91.9	141.1	163.1	-	-	-	-	-	-	-
85.3	164.2	220.5*	-	-	-	-	-	-	-	98.4	131.2	165.3*	-	-	-	-	-	-	-
91.9	152.1	219.4*	-	-	-	-	-	-	-	111.5	114.6	163.1*	-	-	-	-	-	-	-
98.4	142.2	217.2*	-	-	-	-	-	-	-	114.8	111.3	162.6*	-	-	-	159.8	187.4	194.0	-
101.7	137.8	216.3*	-	-	-	-	213.8	-	260.1	124.7	101.2	160.9*	-	-	-	159.8	187.4	194.0	-
108.3	129.0	214.7*	-	-	-	-	213.8	251.3	260.1	137.8	89.7	158.7*	-	-	-	159.8	187.4	194.0	-
111.5	124.6	213.8*	-	-	-	-	213.8	251.3	260.1	150.9	80.0	155.4*	-	-	-	158.4	185.9	191.8	-
124.7	110.2	208.3*	-	-	-	-	213.5	251.3	260.1	164.0	71.7	152.1*	-	-	-	156.5	184.1	189.2	-
137.8	98.5	202.8*	-	-	-	-	212.7	251.3	260.1	173.9	66.2	149.6*	144.4	-	-	154.9	182.4	187.0	-
150.9	88.4	197.3*	-	-	-	-	212.0	249.1	258.7	177.2	64.4	148.8*	144.4	-	-	154.3	181.9	186.3	-
157.5	84.0	194.0*	201.7	-	-	-	211.6	249.1	257.9	190.3	58.0	144.4*	144.4	-	-	151.4	177.8	182.6	-
164.0	79.6	190.7*	201.7	-	-	-	209.1	246.9	254.3	203.4	52.2	141.1*	144.4	-	-	148.6	174.5	178.9	-
177.2	72.3	184.1*	201.7	-	-	-	206.1	242.5	249.1	216.5	47.4	136.7*	144.4	-	-	145.5	170.9	175.3	-
190.3	65.7	178.6*	201.7	-	-	-	202.5	238.1	244.7	229.7	43.0	133.4*	144.4	-	-	142.6	166.4	170.5	-
203.4	60.2	166.4*	201.7	-	-	-	197.7	230.8	237.4	242.8	39.0	122.4*	144.4	-	-	138.5	162.6	167.0	-
210.0	57.8	153.2*	200.6	-	-	-	195.8	226.3	232.2	246.1	38.1	117.7*	144.4	-	-	137.8	161.8	166.2	-
216.5	50.0*	140.0*	200.6	-	-	-	194.0	222.7	227.1	249.3	32.7*	113.1*	144.4	122.4	-	137.1	160.9	165.3	-
226.4	-	-	198.1	174.2	-	-	189.6	215.5	218.8	255.9	31.1*	103.8*	144.4	122.4	-	135.6	158.7	163.1	-
229.7	-	-	197.3	174.2	-	-	188.5	213.1	216.1	269.0	-	-	144.4	122.4	-	131.9	155.8	158.7	-
242.8	-	-	180.8	173.1	-	-	179.7	203.9	203.9	282.2	-	-	133.4	122.4	-	128.6	152.5	153.2	-
255.9	-	-	154.3	170.9	-	-	166.4	189.6	187.4	295.3	-	-	115.7	122.4	-	125.7	148.8	146.6	-
259.2	-	-	147.7	168.1	-	-	163.1	186.1	183.9	308.4	-	-	-	122.4	-	119.3	137.8	134.8	-
269.0	-	-	-	159.8	-	-	153.2	175.6	173.4	318.2	-	-	-	122.4	104.9	113.5	129.8	126.8	-
282.2	-	-	-	151.0	-	-	141.1	162.4	160.2	321.5	-	-	-	122.4	104.9	111.3	127.3	124.6	-
292.0	-	-	-	144.4	132.3	-	132.8	153.0	150.8	334.6	-	-	-	116.8	104.1	102.3	117.9	114.6	-
295.3	-	-	-	142.2	130.1	-	130.1	149.9	147.7	347.8	-	-	-	-	98.5	94.2	109.0	105.8	-
298.6	-	-	-	141.1	128.1	-	127.5	147.3	145.1	360.9	-	-	-	-	93.5	86.5	100.3	97.2	-
308.4	-	-	-	-	122.4	119.8	119.8	139.6	137.4	370.7	-	-	-	-	89.9	81.1	94.0	90.9	-
321.5	-	-	-	-	115.7	110.5	109.5	129.3	126.8	374.0	-	-	-	-	-	79.4	91.9	88.8	-
331.4	-	-	-	-	111.3	104.2	104.2	122.4	119.3	387.1	-	-	-	-	-	72.2	83.7	81.1	-
334.6	-	-	-	-	-	102.1	102.1	120.2	116.8	400.3	-	-	-	-	-	63.8	74.4	72.2	-
347.8	-	-	-	-	-	94.0	108.5	106.0	106.0	413.4	-	-	-	-	-	54.2	63.9	61.9	-
360.9	-	-	-	-	-	85.2	96.6	94.4	94.4	426.5	-	-	-	-	-	46.2	53.5	51.6	-
374.0	-	-	-	-	-	74.3	84.2	82.0	82.0	439.6	-	-	-	-	-	39.0	47.2	44.3	-
387.1	-	-	-	-	-	63.1	73.1	70.0	70.0										
400.3	-	-	-	-	-	55.4	63.8	61.4	61.4										
403.5	-	-	-	-	-	53.4	61.1	58.9	58.9										

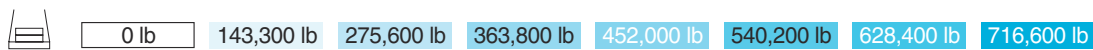

SWSL_1: 36.1 ft – 62.3 ft

SWSL_3/SFSL_3, SWSL_4/SFSL_4: 36.1 ft – 68.9 ft

SFSL_3 + SFSL_4: 496,100 lb + 110,200 lb

* Main boom angle 85°

Main boom angle 87°, 85°, 75°, 65° and 55°, capacities for intermediate boom positions are calculated by the crane control system IC-1

Operation

SWSL, SFSL

363,800 lb + 110,200 lb 36.1-68.9 ft										27.6 ft 32.2 ft/s 360° ASME B30.5									
236.2 ft + 275.6 ft										236.2 ft + 315.0 ft									
SWSL_1					SFSL_1	SFSL_3	SFSL_4	SWSL_1					SFSL_1	SFSL_3	SFSL_4				
0 lb					0 lb - 716,600 lb					0 lb					0 lb - 716,600 lb				
87°/85° 87°/85° 75° 65° 55°					15° 15° 15°					87°/85° 87°/85° 75° 65° 55°					15° 15° 15°				
ft										ft									
1,000 lb										1,000 lb									
88.6	120.2	123.5	-	-	-	-	-	-	-	95.1	89.3	91.3	-	-	-	-	-	-	-
91.9	120.2	122.4	-	-	-	-	-	-	-	98.4	89.1	91.1	-	-	-	-	-	-	-
98.4	117.9	122.4	-	-	-	-	-	-	-	111.5	88.2	89.7	-	-	-	-	-	-	-
111.5	104.9	121.3*	-	-	-	-	-	-	-	124.7	82.9	89.1*	-	-	-	-	-	-	-
124.7	91.7	120.2*	-	-	-	-	-	-	-	137.8	72.3	88.4*	-	-	-	-	-	-	-
128.0	89.0	119.9*	-	-	-	119.0	137.8	141.1	-	141.1	70.1	88.1*	-	-	-	87.5	98.3	101.2	
137.8	80.9	119.0*	-	-	-	119.0	136.7	141.1	-	150.9	63.3	87.1*	-	-	-	86.7	97.5	100.5	
150.9	71.4	116.8*	-	-	-	118.3	136.0	139.6	-	164.0	55.6	85.8*	-	-	-	85.7	96.4	99.1	
164.0	63.3	115.7*	-	-	-	116.8	134.5	137.8	-	177.2	48.7	84.4*	-	-	-	84.7	95.2	97.7	
177.2	56.4	113.5*	-	-	-	114.6	132.3	135.6	-	190.3	42.8	82.9*	-	-	-	82.9	93.2	95.5	
190.3	50.3	111.3*	104.9	-	-	113.2	129.3	132.6	-	203.4	37.5	81.4*	-	-	-	81.1	91.1	93.3	
203.4	44.8	109.3*	104.9	-	-	111.2	126.4	129.7	-	206.7	36.3	81.0*	73.6	-	-	80.7	90.6	92.7	
216.5	39.9	107.1*	104.9	-	-	108.9	123.5	126.8	-	216.5	32.8	79.8*	73.6	-	-	79.6	89.1	91.1	
229.7	35.5	104.7*	104.9	-	-	106.4	120.5	123.8	-	229.7	28.7	78.3*	73.6	-	-	77.5	86.9	88.7	
242.8	31.5	102.3*	104.9	-	-	103.9	117.9	121.3	-	242.8	24.7	76.9*	73.6	-	-	75.5	84.7	86.4	
255.9	28.0	100.1*	104.9	-	-	101.4	114.6	117.9	-	255.9	21.2	75.4*	73.6	-	-	73.4	82.5	84.0	
269.0	24.9	97.9*	104.9	85.8	-	99.1	112.4	114.3	-	269.0	18.1	73.9*	73.6	-	-	71.5	80.2	81.6	
282.2	22.0	92.2*	104.9	85.8	-	96.3	109.9	111.2	-	282.2	15.2	72.5*	73.6	-	-	69.6	77.7	79.1	
285.4	21.4	88.6*	104.9	85.8	-	95.7	109.2	110.6	-	292.0	13.2	71.5*	73.6	57.5	-	68.2	75.8	77.2	
292.0	16.1*	81.6*	104.9	85.8	-	94.5	107.8	109.3	-	295.3	12.6	71.2*	73.6	57.5	-	67.7	75.2	76.5	
295.3	-	-	104.9	85.8	-	93.9	107.1	108.7	-	308.4	10.1	70.1*	73.6	57.5	-	65.8	72.7	74.0	
308.4	-	-	104.9	85.8	-	91.6	104.5	105.6	-	315.0	9.0	68.5*	73.6	57.5	-	64.8	71.4	72.8	
321.5	-	-	101.6	85.8	-	89.1	101.6	102.3	-	321.5	-	66.8*	73.6	57.5	-	63.9	70.2	71.4	
334.6	-	-	87.7	85.8	-	86.9	97.9	98.1	-	324.8	-	64.1*	73.6	57.5	-	63.5	69.6	70.8	
344.5	-	-	-	85.8	71.9	84.9	94.7	94.6	-	331.4	-	58.6*	73.6	57.5	-	62.6	68.3	69.4	
347.8	-	-	-	85.8	71.9	84.4	93.6	93.4	-	334.6	-	-	73.6	57.5	-	62.2	67.7	68.8	
360.9	-	-	-	85.8	71.9	82.2	89.4	88.7	-	347.8	-	-	73.6	57.5	-	60.2	65.2	66.1	
374.0	-	-	-	85.5	71.9	79.8	85.1	84.0	-	360.9	-	-	73.6	57.5	-	58.5	63.0	63.9	
387.1	-	-	-	-	71.7	73.3	80.8	79.3	-	370.7	-	-	67.0	57.5	-	57.3	61.5	62.4	
400.3	-	-	-	-	71.7	67.1	75.8	73.6	-	374.0	-	-	-	57.5	46.1	56.9	60.8	61.9	
410.1	-	-	-	-	71.7	62.6	71.4	68.7	-	387.1	-	-	-	57.5	46.1	55.2	59.0	59.8	
413.4	-	-	-	-	-	61.1	69.9	67.0	-	400.3	-	-	-	57.5	46.1	53.5	57.0	57.9	
426.5	-	-	-	-	-	53.7	62.7	60.5	-	410.1	-	-	-	57.5	45.9	52.4	55.6	56.5	
439.6	-	-	-	-	-	45.9	54.6	52.6	-	413.4	-	-	-	-	45.9	52.0	55.1	56.0	
452.8	-	-	-	-	-	37.7	45.6	43.7	-	426.5	-	-	-	-	45.9	50.7	53.1	54.1	
465.9	-	-	-	-	-	31.4	36.7	34.7	-	439.6	-	-	-	-	45.9	48.0	50.3	51.0	
479.0	-	-	-	-	-	24.5	31.1	28.9	-	446.2	-	-	-	-	45.9	46.0	48.3	48.9	
										452.8	-	-	-	-	-	43.2	46.3	46.7	
										465.9	-	-	-	-	-	36.0	41.4	41.4	
										479.0	-	-	-	-	-	28.8	35.9	35.2	
										492.1	-	-	-	-	-	23.1	29.5	28.0	
										515.1	-	-	-	-	-	12.1	18.5	15.9	

SWSL_1: 36.1 ft – 62.3 ft

SWSL_3/SFSL_3, SWSL_4/SFSL_4: 36.1 ft – 68.9 ft

SFSL_3 + SFSL_4: 496,100 lb + 110,200 lb

* Main boom angle 85°

Main boom angle 87°, 85°, 75°, 65° and 55°, capacities for intermediate boom positions are calculated by the crane control system IC-1

Operation

SWSL, SFSL

363,800 lb + 110,200 lb 36.1-68.9 ft 27.6 ft 32.2 ft/s 360° ASME B30.5										
255.9 ft + 78.7 ft					255.9 ft + 118.1 ft					
SWSL_1					SFSL_1	SFSL_3	SFSL_4			
0 lb					0 lb - 716,600 lb					
87°/85° 87°/85° 75° 65° 55°					15° 15° 15°					
ft	1,000 lb									
42.7	363.8	429.9	-	-	-	-	-	-	-	
45.9	341.7	423.3	-	-	-	-	-	-	-	
52.5	306.4	412.3	-	-	-	-	-	-	-	
59.1	277.8	427.7*	-	-	-	-	-	-	-	
62.3	264.6	423.3*	-	-	-	418.9	-	564.4	-	
65.6	251.3	416.7*	-	-	-	418.9	-	564.4	-	
68.9	241.4	410.1*	-	-	-	418.9	533.5	564.4	-	
72.2	231.5	403.4*	-	-	-	418.9	533.5	564.4	-	
78.7	215.0	390.2*	-	-	-	418.9	526.9	560.0	-	
85.3	199.5	377.0*	-	-	-	416.7	526.9	560.0	-	
91.9	186.3	363.8*	-	-	-	414.5	522.5	557.8	-	
95.1	180.8	358.3*	-	-	-	412.3	513.7	555.6	-	
98.4	164.2*	352.7*	-	-	-	410.1	513.7	555.6	-	
105.0	154.3*	341.7*	-	-	-	407.1	507.1	537.2	-	
111.5	-	-	405.7	-	-	404.2	507.1	523.2	-	
124.7	-	-	392.4	-	-	392.4	479.1	479.9	-	
137.8	-	-	372.6	-	-	383.6	423.3	421.1	-	
150.9	-	-	346.1	-	-	346.9	379.2	377.0	-	
164.0	-	-	-	-	-	311.6	340.2	338.0	-	
170.6	-	-	-	293.2	-	294.7	323.3	321.1	-	
177.2	-	-	-	280.0	-	277.8	306.4	304.2	-	
190.3	-	-	-	257.9	-	251.3	278.5	276.3	-	
203.4	-	-	-	-	-	226.4	253.5	250.6	-	
216.5	-	-	-	-	-	206.1	231.5	227.1	-	
219.8	-	-	-	-	201.7	201.7	224.9	222.7	-	
229.7	-	-	-	-	191.8	188.5	211.6	209.4	-	
242.8	-	-	-	-	-	172.3	194.7	192.5	-	
255.9	-	-	-	-	-	157.6	178.6	176.4	-	
269.0	-	-	-	-	-	145.1	163.1	160.2	-	
282.2	-	-	-	-	-	130.8	145.1	142.0	-	
295.3	-	-	-	-	-	114.6	124.6	122.4	-	
305.1	-	-	-	-	-	102.5	114.6	111.3	-	
52.5	282.2	321.9	-	-	-	-	-	-	-	
59.1	255.7	315.3	-	-	-	-	-	-	-	
65.6	233.7	326.3*	-	-	-	-	-	-	-	
72.2	215.0	319.7*	-	-	-	-	-	-	-	
75.5	206.7	316.4*	-	-	-	-	-	313.1	-	
78.7	198.4	313.1*	-	-	-	-	-	313.1	-	
82.0	191.3	309.7*	-	-	-	-	-	313.1	403.4	
85.3	184.1	306.4*	-	-	-	-	-	313.1	403.4	
91.9	172.0	297.6*	-	-	-	-	-	313.1	403.4	
98.4	160.9	291.0*	-	-	-	-	-	313.1	401.2	
111.5	142.2	273.4*	-	-	-	-	-	308.6	394.6	
124.7	126.8	257.9*	-	-	-	-	-	305.0	388.0	
128.0	123.8	254.6*	304.2	-	-	-	-	304.2	388.0	
134.5	117.9	248.0*	304.2	-	-	-	-	302.8	388.0	
137.8	107.1*	244.7*	302.0	-	-	-	-	302.0	388.0	
144.4	102.3*	238.1*	297.6	-	-	-	-	296.9	377.7	
150.9	-	-	293.2	-	-	-	-	293.9	369.6	
164.0	-	-	280.0	-	-	-	-	285.1	344.7	
177.2	-	-	264.6	-	-	-	-	277.8	310.9	
187.0	-	-	253.5	-	-	-	-	260.1	289.9	
190.3	-	-	-	253.5	-	-	-	254.3	282.9	
203.4	-	-	-	233.7	-	-	-	231.5	257.2	
216.5	-	-	-	217.2	-	-	-	210.5	233.7	
229.7	-	-	-	202.8	-	-	-	192.9	215.0	
242.8	-	-	-	-	-	-	-	176.4	198.0	
246.1	-	-	-	-	-	-	-	172.0	194.0	
255.9	-	-	-	-	-	-	-	163.1	181.9	
269.0	-	-	-	-	-	-	-	154.3	167.9	
282.2	-	-	-	-	-	-	-	137.1	155.1	
295.3	-	-	-	-	-	-	-	125.7	143.3	
308.4	-	-	-	-	-	-	-	115.4	128.2	
321.5	-	-	-	-	-	-	-	103.3	112.2	
334.6	-	-	-	-	-	-	-	89.5	97.7	
344.5	-	-	-	-	-	-	-	80.2	89.5	

0 lb 143,300 lb 275,600 lb 363,800 lb 452,000 lb 540,200 lb 628,400 lb 716,600 lb

SWSL_1: 36.1 ft – 62.3 ft

SWSL_3/SFSL_3, SWSL_4/SFSL_4: 36.1 ft – 68.9 ft

SFSL_3 + SFSL_4: 496,100 lb + 110,200 lb

* Main boom angle 85°

Main boom angle 87°, 85°, 75°, 65° and 55°, capacities for intermediate boom positions are calculated by the crane control system IC-1

Operation

SWSL, SFSL

363,800 lb + 110,200 lb 36.1-68.9 ft										27.6 ft 32.2 ft/s 360° ASME B30.5									
255.9 ft + 157.5 ft										255.9 ft + 196.9 ft									
SWSL_1					SFSL_1	SFSL_3	SFSL_4	SWSL_1					SFSL_1	SFSL_3	SFSL_4				
0 lb					0 lb - 716,600 lb					0 lb					0 lb - 716,600 lb				
87°/85° 87°/85° 75° 65° 55°					15° 15° 15°					87°/85° 87°/85° 75° 65° 55°					15° 15° 15°				
ft										ft									
1,000 lb										1,000 lb									
62.3	227.1	244.7	-	-	-	-	-	-	-	68.9	184.1	188.5	-	-	-	-	-	-	-
65.6	217.2	242.5	-	-	-	-	-	-	-	72.2	181.9	187.4	-	-	-	-	-	-	-
72.2	199.5	238.1	-	-	-	-	-	-	-	78.7	170.9	185.2	-	-	-	-	-	-	-
78.7	184.1	246.9*	-	-	-	-	-	-	-	85.3	157.6	188.5*	-	-	-	-	-	-	-
85.3	170.9	244.7*	-	-	-	-	-	-	-	91.9	146.6	187.4*	-	-	-	-	-	-	-
88.6	164.8	242.5*	-	-	-	-	235.9	-	-	98.4	136.7	185.2*	-	-	-	-	-	-	-
91.9	158.7	240.3*	-	-	-	-	235.9	-	-	101.7	132.6	184.1*	-	-	-	181.9	231.5	242.5	-
95.1	153.2	238.1*	-	-	-	-	235.9	306.4	321.9	111.5	120.2	180.8*	-	-	-	181.9	231.5	242.5	-
98.4	147.7	235.9*	-	-	-	-	235.9	306.4	321.9	124.7	106.7	176.4*	-	-	-	181.5	231.5	242.5	-
111.5	130.1	227.1*	-	-	-	-	235.9	306.4	321.9	137.8	95.0	169.8*	-	-	-	180.8	231.5	242.5	-
124.7	115.7	217.2*	-	-	-	-	234.4	303.5	317.5	150.9	85.3	164.2*	-	-	-	178.6	231.5	239.6	-
137.8	104.1	207.2*	-	-	-	-	231.5	302.0	317.5	160.8	79.0	159.3*	172.0	-	-	176.9	229.3	237.4	-
147.6	96.6	199.8*	229.3	-	-	-	229.3	297.6	314.2	164.0	76.9	157.6*	172.0	-	-	176.4	228.5	236.6	-
150.9	94.1	197.3*	229.3	-	-	-	228.5	297.6	313.8	172.2	69.7	151.0*	172.0	-	-	174.2	227.1	233.7	-
164.0	85.5	189.6*	227.1	-	-	-	224.9	295.4	310.9	190.3	63.3	145.5*	172.0	-	-	171.2	221.9	229.3	-
170.6	81.8	185.7*	223.8	-	-	-	222.7	295.4	308.6	203.4	57.8	140.0*	169.8	-	-	167.6	216.1	223.0	-
177.2	71.7*	181.9*	220.5	-	-	-	220.5	295.4	306.4	210.0	55.3	137.8*	167.6	-	-	165.3	212.7	219.0	-
180.4	70.1*	179.7*	219.1	-	-	-	219.4	291.4	300.2	216.5	47.6*	135.6*	165.3	-	-	163.1	209.4	216.1	-
190.3	-	-	215.0	-	-	-	216.1	279.3	281.5	219.8	46.5*	134.5*	164.2	-	-	162.0	207.6	213.7	-
203.4	-	-	207.2	-	-	-	208.9	260.1	257.9	229.7	-	-	160.9	-	-	158.7	202.1	206.5	-
213.3	-	-	200.3	197.3	-	-	204.5	243.6	241.4	236.2	-	-	158.2	144.4	-	156.5	198.4	201.7	-
216.5	-	-	198.4	197.3	-	-	202.8	238.1	235.9	242.8	-	-	155.4	144.4	-	154.3	194.2	196.7	-
226.4	-	-	190.7	195.8	-	-	193.5	223.8	221.3	255.9	-	-	149.9	144.4	-	149.9	186.3	185.2	-
229.7	-	-	-	195.1	-	-	190.3	219.0	216.5	262.5	-	-	146.6	144.4	-	148.1	179.3	178.2	-
242.8	-	-	-	183.0	-	-	176.7	201.0	198.8	269.0	-	-	-	144.4	-	146.2	172.3	171.2	-
255.9	-	-	-	170.9	-	-	162.0	184.1	181.9	282.2	-	-	-	143.3	-	139.1	159.1	157.6	-
269.0	-	-	-	160.9	-	-	148.8	170.1	167.9	295.3	-	-	-	140.0	-	129.0	146.6	144.4	-
275.6	-	-	-	-	142.2	-	142.2	163.1	160.9	301.8	-	-	-	135.6	121.3	123.8	141.1	138.5	-
282.2	-	-	-	-	137.8	-	137.1	157.3	155.1	305.1	-	-	-	133.4	120.2	121.3	138.3	135.6	-
295.3	-	-	-	-	130.1	-	125.7	145.5	143.3	308.4	-	-	-	-	117.9	118.7	135.6	132.6	-
305.1	-	-	-	-	125.7	-	117.9	136.9	135.0	321.5	-	-	-	-	111.3	109.1	125.2	121.6	-
308.4	-	-	-	-	-	-	115.4	134.0	132.3	334.6	-	-	-	-	106.3	100.1	114.6	111.3	-
321.5	-	-	-	-	-	-	106.0	123.8	121.3	344.5	-	-	-	-	102.1	94.0	107.8	104.6	-
334.6	-	-	-	-	-	-	97.7	113.5	110.2	347.8	-	-	-	-	-	92.0	105.5	102.4	-
347.8	-	-	-	-	-	-	88.8	100.3	97.6	360.9	-	-	-	-	-	84.2	96.7	93.5	-
360.9	-	-	-	-	-	-	77.5	86.9	84.6	374.0	-	-	-	-	-	77.2	88.2	84.9	-
374.0	-	-	-	-	-	-	65.3	74.7	71.2	387.1	-	-	-	-	-	67.6	77.0	74.4	-
380.6	-	-	-	-	-	-	61.5	71.0	67.7	400.3	-	-	-	-	-	57.7	65.6	63.5	-
										413.4	-	-	-	-	-	49.2	55.1	52.0	-
										419.9	-	-	-	-	-	46.1	52.2	48.9	-

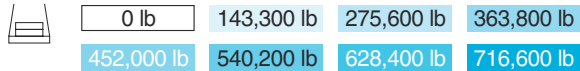

SWSL_1: 36.1 ft – 62.3 ft
 SWSL_3/SFSL_3, SWSL_4/SFSL_4: 36.1 ft – 68.9 ft
 SFSL_3 + SFSL_4: 496,100 lb + 110,200 lb

* Main boom angle 85°
 Main boom angle 87°, 85°, 75°, 65° and 55°, capacities for intermediate boom positions are calculated by the crane control system IC-1

Operation

SWSL, SFSL

363,800 lb + 110,200 lb 36.1-68.9 ft										27.6 ft 32.2 ft/s 360° ASME B30.5									
255.9 ft + 236.2 ft										255.9 ft + 275.6 ft									
SWSL_1					SFSL_1	SFSL_3	SFSL_4	SWSL_1					SFSL_1	SFSL_3	SFSL_4				
0 lb					0 lb - 716,600 lb					0 lb					0 lb - 716,600 lb				
87°/85° 87°/85° 75° 65° 55°					15° 15° 15°					87°/85° 87°/85° 75° 65° 55°					15° 15° 15°				
ft										ft									
1,000 lb										1,000 lb									
78.7	138.9	142.2	-	-	-	-	-	-	-	88.6	104.9	107.6	-	-	-	-	-	-	-
85.3	137.8	141.1	-	-	-	-	-	-	-	91.9	104.7	107.1	-	-	-	-	-	-	-
91.9	135.6	140.0	-	-	-	-	-	-	-	98.4	104.1	106.3	-	-	-	-	-	-	-
98.4	125.7	141.1*	-	-	-	-	-	-	-	111.5	100.5	106.0*	-	-	-	-	-	-	-
111.5	110.2	138.9*	-	-	-	-	-	-	-	124.7	88.0	104.9*	-	-	-	-	-	-	-
114.8	107.0	138.3*	-	-	-	136.7	-	180.8	128.0	85.3	104.5*	-	-	103.6	129.0	133.4	-	-	-
121.4	100.6	137.2*	-	-	-	136.7	174.0	180.6	137.8	77.4	103.2*	-	-	103.2	129.0	133.4	-	-	-
124.7	97.4	136.7*	-	-	-	136.7	174.2	180.4	150.9	68.3	101.2*	-	-	102.6	128.2	131.9	-	-	-
137.8	86.4	133.4*	-	-	-	136.7	173.1	179.7	164.0	60.6	99.2*	-	-	101.6	126.8	130.1	-	-	-
150.9	76.9	130.1*	-	-	-	135.2	171.6	177.5	177.2	53.8	97.0*	-	-	100.1	124.6	127.9	-	-	-
164.0	68.8	126.8*	-	-	-	133.7	169.8	175.3	190.3	47.8	94.4*	-	-	98.5	122.4	125.7	-	-	-
177.2	61.7	122.4*	125.7	-	-	132.3	167.6	173.1	196.9	45.2	93.1*	91.5	-	97.7	121.3	124.6	-	-	-
190.3	55.6	119.0*	125.7	-	-	130.1	164.6	169.4	203.4	42.5	91.9*	91.5	-	96.8	120.2	123.5	-	-	-
203.4	50.0	114.6*	125.7	-	-	127.5	161.7	166.1	216.5	37.9	89.5*	91.5	-	94.8	117.9	121.3	-	-	-
216.5	45.2	110.2*	125.7	-	-	124.6	158.7	163.1	229.7	33.5	86.9*	91.5	-	92.7	115.7	118.6	-	-	-
229.7	41.0	107.4*	124.6	-	-	122.4	154.3	158.4	242.8	29.8	84.2*	91.5	-	90.6	113.1	115.7	-	-	-
242.8	37.3	103.8*	123.5	-	-	119.8	151.0	154.3	255.9	26.5	81.8*	91.5	-	88.4	110.2	112.4	-	-	-
249.3	35.5	102.2*	122.4	-	-	118.3	148.8	152.1	269.0	23.1	79.4*	91.5	-	86.3	108.0	110.4	-	-	-
255.9	28.9*	100.5*	121.3	-	-	116.8	146.6	149.9	282.2	20.5	77.2*	91.3	74.5	-	84.1	105.7	108.0	-	-
259.2	-	-	120.4	105.6	-	115.2	145.9	149.0	285.4	19.8	76.6*	90.9	74.5	-	83.6	105.2	107.4	-	-
269.0	-	-	117.9	105.6	-	113.5	143.7	146.2	295.3	13.7*	74.7*	89.7	74.5	-	82.0	103.4	105.4	-	-
282.2	-	-	115.7	105.6	-	110.3	140.4	142.2	308.4	-	-	88.2	74.5	-	79.6	100.8	102.7	-	-
295.3	-	-	111.3	105.6	-	107.6	136.7	137.8	321.5	-	-	86.2	74.5	-	77.5	98.4	99.9	-	-
301.8	-	-	110.2	105.4	-	105.6	133.0	133.4	334.6	-	-	84.2	74.3	-	75.4	95.9	97.4	-	-
308.4	-	-	-	105.4	-	104.0	129.3	129.0	337.9	-	-	83.8	74.3	-	74.4	94.5	96.2	-	-
321.5	-	-	-	105.4	-	100.9	121.0	118.8	347.8	-	-	-	74.3	-	72.8	91.1	92.3	-	-
328.1	-	-	-	-	88.8	99.3	116.2	114.2	357.6	-	-	-	74.3	61.3	71.0	87.6	88.4	-	-
334.6	-	-	-	104.7	88.2	97.7	111.3	109.6	360.9	-	-	-	74.3	61.1	70.2	86.4	87.0	-	-
344.5	-	-	-	104.5	88.2	93.0	105.3	103.0	374.0	-	-	-	74.3	61.1	67.9	81.6	81.6	-	-
347.8	-	-	-	-	88.2	91.5	103.2	100.8	380.6	-	-	-	74.3	61.1	66.9	79.2	78.4	-	-
360.9	-	-	-	-	88.2	84.7	95.1	92.2	387.1	-	-	-	-	61.1	65.8	76.9	75.3	-	-
374.0	-	-	-	-	84.7	77.6	86.9	84.0	400.3	-	-	-	-	60.6	63.5	71.3	68.7	-	-
383.9	-	-	-	-	81.6	72.6	81.1	78.3	413.4	-	-	-	-	60.6	58.6	64.8	62.2	-	-
387.1	-	-	-	-	-	71.0	79.3	76.4	419.9	-	-	-	-	60.6	55.9	61.5	59.0	-	-
400.3	-	-	-	-	-	64.7	72.1	69.1	426.5	-	-	-	-	-	53.2	58.4	55.9	-	-
413.4	-	-	-	-	-	57.8	65.0	62.2	439.6	-	-	-	-	-	47.1	52.5	49.8	-	-
426.5	-	-	-	-	-	48.9	56.4	53.8	452.8	-	-	-	-	-	39.9	46.7	44.1	-	-
439.6	-	-	-	-	-	40.0	46.7	44.8	465.9	-	-	-	-	-	32.3	38.8	37.2	-	-
452.8	-	-	-	-	-	34.6	37.0	35.1	479.0	-	-	-	-	-	25.2	30.4	29.5	-	-
456.0	-	-	-	-	-	32.6	35.7	32.8	492.1	-	-	-	-	-	20.1	22.3	20.7	-	-
									495.4	-	-	-	-	-	18.1	21.2	18.5	-	-

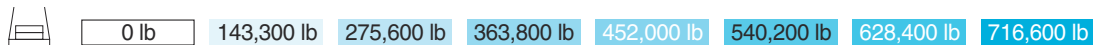

SWSL_1: 36.1 ft – 62.3 ft

SWSL_3/SFSL_3, SWSL_4/SFSL_4: 36.1 ft – 68.9 ft









SFSL_3 + SFSL_4: 496,100 lb + 110,200 lb

* Main boom angle 85°



Main boom angle 87°, 85°, 75°, 65° and 55°, capacities for intermediate boom positions are calculated by the crane control system IC-1

Operation

SWSL, SFSL

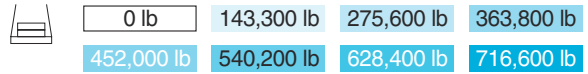
 363,800 lb + 110,200 lb  36.1-68.9 ft										 27.6 ft  32.2 ft/s  360°  ASME B30.5														
 255.9 ft + 315.0 ft										 275.6 ft + 78.7 ft														
SWSL_1					SFSL_1	SFSL_3	SFSL_4						SWSL_1					SFSL_1	SFSL_3	SFSL_4				
0 lb					0 lb - 716,600 lb					0 lb					0 lb - 716,600 lb									
87°/85° 87°/85° 75° 65° 55°					15° 15° 15°					87°/85° 87°/85° 75° 65° 55°					15° 15° 15°									
ft										1,000 lb														
98.4	77.2	79.4	-	-	-	-	-	-	-	45.9	326.3	383.6	-	-	-	-	-	-	-					
111.5	76.3	78.0	-	-	-	-	-	-	-	52.5	293.2	372.6	-	-	-	-	-	-	-					
124.7	75.0	77.4*	-	-	-	-	-	-	-	59.1	264.6	385.8*	-	-	-	-	-	-	-					
137.8	69.0	76.7*	-	-	-	-	-	-	-	62.3	253.5	381.4*	-	-	-	374.8	-	522.5	-					
141.1	66.9	76.4*	-	-	-	-	75.8	92.8	95.9	65.6	242.5	377.0*	-	-	-	374.8	-	522.5	-					
150.9	60.4	75.4*	-	-	-	-	75.3	92.2	95.2	68.9	232.6	371.5*	-	-	-	374.8	493.8	522.5	-					
164.0	52.7	74.3*	-	-	-	-	74.6	91.3	94.2	72.2	222.7	366.0*	-	-	-	374.8	493.8	522.5	-					
177.2	46.3	72.8*	-	-	-	-	73.9	90.4	93.0	78.7	206.1	352.7*	-	-	-	372.6	487.2	520.3	-					
190.3	40.6	71.4*	-	-	-	-	72.4	88.5	91.3	85.3	191.8	341.7*	-	-	-	372.6	487.2	518.1	-					
203.4	35.3	69.7*	-	-	-	-	70.9	86.6	89.4	91.9	179.7	330.7*	-	-	-	370.4	482.8	515.9	-					
213.3	32.0	68.5*	64.2	-	-	-	69.8	85.1	88.0	98.4	169.8	319.7*	-	-	-	366.0	482.8	515.9	-					
216.5	30.9	68.1*	64.2	-	-	-	69.4	84.7	87.5	108.3	143.3*	304.2*	-	-	-	361.6	471.8	501.6	-					
229.7	26.7	66.4*	64.2	-	-	-	67.8	82.9	85.5	111.5	-	-	-	-	-	360.1	471.8	499.7	-					
242.8	22.9	64.8*	64.2	-	-	-	66.1	81.0	83.3	118.1	-	-	361.6	-	-	357.1	471.8	496.0	-					
255.9	19.6	63.1*	64.2	-	-	-	64.4	78.9	81.1	124.7	-	-	354.9	-	-	350.5	454.2	469.6	-					
269.0	16.5	61.3*	64.2	-	-	-	62.6	76.7	79.0	137.8	-	-	335.1	-	-	341.7	418.9	416.7	-					
282.2	13.7	59.5*	64.2	-	-	-	60.8	74.6	76.6	150.9	-	-	315.3	-	-	331.4	374.8	372.6	-					
295.3	11.0	58.0*	64.2	-	-	-	59.1	72.3	74.3	154.2	-	-	308.6	-	-	328.9	363.8	361.6	-					
301.8	9.8	57.2*	64.2	49.6	-	-	58.4	71.2	72.9	164.0	-	-	-	-	-	309.4	335.1	332.9	-					
305.1	9.3	56.8*	64.2	49.6	-	-	58.0	70.7	72.3	177.2	-	-	-	273.4	-	275.6	299.8	297.6	-					
308.4	-	56.4*	64.2	49.6	-	-	57.5	70.1	71.7	190.3	-	-	-	251.3	-	249.1	273.4	269.7	-					
321.5	-	54.9*	63.7	49.6	-	-	55.8	67.9	69.4	200.1	-	-	-	238.1	-	230.4	254.4	250.2	-					
324.8	-	54.6*	63.6	49.6	-	-	55.3	67.4	68.8	203.4	-	-	-	-	-	224.9	248.7	244.7	-					
334.6	-	53.6*	63.3	49.6	-	-	54.0	65.7	66.8	216.5	-	-	-	-	-	202.8	224.9	222.7	-					
347.8	-	-	62.8	49.6	-	-	52.5	63.5	64.4	229.7	-	-	-	-	-	185.9	206.5	204.3	-					
360.9	-	-	61.9	49.6	-	-	50.7	61.0	61.9	232.9	-	-	-	-	181.9	181.7	201.9	199.7	-					
374.0	-	-	61.3	49.6	-	-	49.2	59.1	59.7	242.8	-	-	-	-	174.2	170.1	189.6	187.0	-					
377.3	-	-	61.1	49.6	-	-	48.6	58.6	59.2	255.9	-	-	-	-	-	155.4	174.2	170.9	-					
383.9	-	-	-	49.6	38.8	-	47.8	57.8	58.1	269.0	-	-	-	-	-	142.2	160.2	157.6	-					
387.1	-	-	-	49.6	38.8	-	47.5	57.3	57.5	282.2	-	-	-	-	-	130.1	147.3	144.4	-					
400.3	-	-	-	49.6	38.8	-	45.9	55.5	55.3	295.3	-	-	-	-	-	119.0	130.1	127.9	-					
413.4	-	-	-	49.6	38.8	-	44.3	53.6	53.1	308.4	-	-	-	-	-	104.2	112.7	110.2	-					
419.9	-	-	-	49.6	38.8	-	43.7	52.7	52.0	321.5	-	-	-	-	-	88.6	99.6	95.5	-					
426.5	-	-	-	-	38.8	-	42.4	51.8	50.9															
439.6	-	-	-	-	38.8	-	40.8	49.3	47.9															
452.8	-	-	-	-	38.8	-	39.2	45.4	43.0															
459.3	-	-	-	-	38.8	-	37.3	42.8	40.4															
465.9	-	-	-	-	-	-	35.3	40.3	37.8															
479.0	-	-	-	-	-	-	30.1	35.2	32.6															
492.1	-	-	-	-	-	-	23.4	30.4	27.8															
518.4	-	-	-	-	-	-	12.3	16.2	14.4															
524.9	-	-	-	-	-	-	9.7	12.3	10.6															
528.2	-	-	-	-	-	-	-	10.4	-															



SWSL_1:  **36.1 ft – 62.3 ft**
 SWSL_3/SFSL_3, SWSL_4/SFSL_4:  **36.1 ft – 68.9 ft**
 SFSL_3 + SFSL_4:  **496,100 lb + 110,200 lb**

* Main boom angle 85°
 Main boom angle 87°, 85°, 75°, 65° and 55°, capacities for intermediate boom positions are calculated by the crane control system IC-1

Operation

SWSL, SFSL

363,800 lb + 110,200 lb 36.1-68.9 ft 27.6 ft 32.2 ft/s 360° ASME B30.5										
275.6 ft + 118.1 ft					275.6 ft + 157.5 ft					
SWSL_1					SFSL_1	SFSL_3	SFSL_4			
0 lb					0 lb - 716,600 lb					
87°/85° 87°/85° 75° 65° 55°					15° 15° 15°					
ft	1,000 lb									
52.5	271.2	293.2	-	-	-	-	-	-	-	
59.1	244.7	286.6	-	-	-	-	-	-	-	
65.6	224.9	282.2	-	-	-	-	-	-	-	
72.2	206.1	291.0	-	-	-	-	-	-	-	
75.5	198.4	287.7*	-	-	-	282.2	-	-	-	
78.7	190.7	284.4*	-	-	-	282.2	-	-	-	
82.0	184.1	281.1*	-	-	-	282.2	372.6	399.0	-	
85.3	177.5	277.8*	-	-	-	282.2	377.0	401.2	-	
91.9	165.3	271.2*	-	-	-	282.2	377.0	399.0	-	
98.4	155.4	264.6*	-	-	-	282.2	377.0	399.0	-	
111.5	136.7	249.1*	-	-	-	277.8	368.2	394.6	-	
124.7	122.4	235.9*	-	-	-	273.4	363.8	390.2	-	
134.5	113.5	226.0*	271.2	-	-	270.1	363.8	390.2	-	
137.8	102.3*	222.7*	271.2	-	-	269.0	363.8	390.2	-	
144.4	97.4*	218.3*	267.5	-	-	266.0	357.9	378.5	-	
150.9	-	-	264.6	-	-	263.1	354.2	366.7	-	
164.0	-	-	253.5	-	-	256.5	335.8	337.3	-	
177.2	-	-	240.3	-	-	249.1	306.4	302.0	-	
190.3	-	-	224.9	-	-	240.3	278.5	274.1	-	
193.6	-	-	222.7	-	-	238.1	271.5	267.1	-	
200.1	-	-	-	229.3	-	231.5	258.7	254.6	-	
203.4	-	-	-	227.1	-	227.1	252.8	249.1	-	
216.5	-	-	-	211.6	-	207.2	229.3	227.1	-	
229.7	-	-	-	197.3	-	188.9	211.1	208.0	-	
236.2	-	-	-	190.7	-	179.7	201.7	198.4	-	
242.8	-	-	-	-	-	172.3	193.6	190.3	-	
255.9	-	-	-	-	-	157.6	177.5	174.2	-	
259.2	-	-	-	-	154.3	154.5	174.0	170.7	-	
269.0	-	-	-	-	147.7	145.1	163.5	160.2	-	
278.9	-	-	-	-	141.1	136.0	153.6	150.2	-	
282.2	-	-	-	-	-	133.0	150.6	147.2	-	
295.3	-	-	-	-	-	121.3	138.9	135.6	-	
308.4	-	-	-	-	-	111.7	127.9	124.6	-	
321.5	-	-	-	-	-	102.2	115.5	112.1	-	
334.6	-	-	-	-	-	92.8	101.9	98.1	-	
347.8	-	-	-	-	-	79.5	87.3	83.6	-	
360.9	-	-	-	-	-	67.2	76.1	72.3	-	

275.6 ft + 157.5 ft										
SWSL_1					SFSL_1	SFSL_3	SFSL_4			
0 lb					0 lb - 716,600 lb					
87°/85° 87°/85° 75° 65° 55°					15° 15° 15°					
ft	1,000 lb									
62.3	216.1	222.7	-	-	-	-	-	-	-	
65.6	207.2	220.5	-	-	-	-	-	-	-	
72.2	190.7	218.3	-	-	-	-	-	-	-	
78.7	176.4	222.7*	-	-	-	-	-	-	-	
85.3	163.1	220.5*	-	-	-	-	-	-	-	
91.9	152.1	217.2*	-	-	-	216.1	-	304.2	-	
98.4	142.2	213.8*	-	-	-	216.1	291.0	304.2	-	
111.5	125.7	205.0*	-	-	-	215.3	291.0	304.2	-	
124.7	111.3	196.2*	-	-	-	213.5	288.8	302.0	-	
137.8	100.1	187.4*	-	-	-	210.5	288.8	302.0	-	
150.9	90.4	178.6*	206.1	-	-	207.6	282.2	297.6	-	
164.0	82.2	170.9*	203.9	-	-	203.9	277.8	291.7	-	
173.9	76.9	165.1*	200.6	-	-	200.6	275.9	286.2	-	
177.2	67.9*	163.1*	199.5	-	-	199.5	275.6	284.4	-	
183.7	65.0*	159.8*	196.2	-	-	197.3	271.2	277.8	-	
190.3	-	-	192.9	-	-	195.1	266.8	271.2	-	
203.4	-	-	185.2	-	-	189.6	252.8	253.5	-	
216.5	-	-	178.6	-	-	184.1	233.7	231.5	-	
223.1	-	-	174.2	176.4	-	180.0	223.4	221.2	-	
229.7	-	-	169.8	175.3	-	177.1	213.5	211.6	-	
242.8	-	-	-	174.2	-	169.4	195.8	194.4	-	
255.9	-	-	-	167.6	-	159.8	179.7	177.5	-	
269.0	-	-	-	157.6	-	146.6	165.7	163.5	-	
275.6	-	-	-	153.2	-	140.0	158.7	156.5	-	
282.2	-	-	-	-	-	134.9	152.5	150.3	-	
285.4	-	-	-	-	130.1	132.1	149.4	147.2	-	
295.3	-	-	-	-	124.6	123.5	140.0	137.8	-	
308.4	-	-	-	-	117.9	113.3	129.5	126.8	-	
318.2	-	-	-	-	113.5	106.0	122.0	118.6	-	
321.5	-	-	-	-	-	103.7	119.4	116.0	-	
334.6	-	-	-	-	-	94.6	109.1	105.6	-	
347.8	-	-	-	-	-	86.6	99.6	96.0	-	
360.9	-	-	-	-	-	78.0	89.0	86.9	-	
374.0	-	-	-	-	-	68.8	76.9	74.7	-	
387.1	-	-	-	-	-	57.5	64.6	62.4	-	
397.0	-	-	-	-	-	50.9	57.5	54.0	-	

0 lb 143,300 lb 275,600 lb 363,800 lb 452,000 lb 540,200 lb 628,400 lb 716,600 lb

SWSL_1: 36.1 ft – 62.3 ft

SWSL_3/SFSL_3, SWSL_4/SFSL_4: 36.1 ft – 68.9 ft

SFSL_3 + SFSL_4: 496,100 lb + 110,200 lb

* Main boom angle 85°

Main boom angle 87°, 85°, 75°, 65° and 55°, capacities for intermediate boom positions are calculated by the crane control system IC-1

Operation

SWSL, SFSL

363,800 lb + 110,200 lb 36.1-68.9 ft										27.6 ft 32.2 ft/s 360° ASME B30.5									
275.6 ft + 196.9 ft										275.6 ft + 236.2 ft									
SWSL_1					SFSL_1	SFSL_3	SFSL_4	SWSL_1					SFSL_1	SFSL_3	SFSL_4				
0 lb					0 lb - 716,600 lb					0 lb					0 lb - 716,600 lb				
87°/85° 87°/85° 75° 65° 55°					15° 15° 15°					87°/85° 87°/85° 75° 65° 55°					15° 15° 15°				
ft										ft									
1,000 lb										1,000 lb									
72.2	168.7	172.0	-	-	-	-	-	-	-	78.7	127.9	131.2	-	-	-	-	-	-	-
78.7	163.1	169.8	-	-	-	-	-	-	-	85.3	126.8	130.1	-	-	-	-	-	-	-
85.3	151.0	167.6	-	-	-	-	-	-	-	91.9	125.7	127.9	-	-	-	-	-	-	-
91.9	141.1	170.9*	-	-	-	-	-	-	-	98.4	120.2	130.1*	-	-	-	-	-	-	-
98.4	131.2	169.8*	-	-	-	-	-	-	-	111.5	105.6	127.9*	-	-	-	-	-	-	-
105.0	122.9	167.6*	-	-	-	166.4	220.5	231.5	-	118.1	99.3	126.2*	-	-	125.7	-	-	174.2	
111.5	114.6	165.3*	-	-	-	165.9	220.5	231.5	-	124.7	93.0	124.6*	-	-	125.3	167.6	173.8	-	
124.7	102.3	159.8*	-	-	-	165.0	220.5	231.5	-	137.8	82.5	122.4*	-	-	124.6	166.4	173.1	-	
137.8	91.3	154.3*	-	-	-	164.2	220.5	231.5	-	150.9	73.4	119.0*	-	-	123.1	165.7	171.6	-	
150.9	81.8	148.8*	-	-	-	162.0	220.5	230.0	-	164.0	65.7	114.6*	-	-	121.6	164.2	169.8	-	
164.0	73.6	143.3*	-	-	-	159.8	219.4	227.8	-	177.2	58.9	111.3*	-	-	120.2	162.0	167.6	-	
167.3	71.9	141.6*	153.2	-	-	159.3	218.8	227.1	-	183.7	55.9	109.6*	114.6	-	119.0	160.9	166.1	-	
177.2	66.6	136.7*	153.2	-	-	157.6	217.2	224.9	-	190.3	52.9	107.8*	114.6	-	117.9	159.8	164.6	-	
190.3	60.6	131.2*	152.1	-	-	154.7	213.5	221.2	-	203.4	47.6	103.8*	114.6	-	116.2	157.3	161.7	-	
203.4	55.3	126.8*	149.9	-	-	151.2	209.4	216.1	-	216.5	43.0	100.1*	113.5	-	113.5	154.3	158.7	-	
210.0	52.9	124.6*	147.7	-	-	149.5	207.2	213.1	-	229.7	38.8	96.6*	113.5	-	111.2	150.8	155.4	-	
216.5	44.5*	122.4*	145.5	-	-	147.7	205.0	210.5	-	242.8	35.1	93.0*	111.3	-	108.5	147.0	151.0	-	
219.8	43.4*	121.3*	144.4	-	-	146.8	202.6	208.1	-	249.3	33.5	91.5*	110.2	-	107.1	145.1	148.8	-	
229.7	-	-	141.1	-	-	144.0	196.0	200.8	-	255.9	26.5*	89.9*	109.1	-	105.6	143.3	146.6	-	
242.8	-	-	135.6	130.1	-	139.3	187.8	191.1	-	259.2	25.6*	89.1*	108.4	-	104.9	142.4	145.5	-	
255.9	-	-	130.1	130.1	-	135.6	179.7	180.8	-	265.7	-	-	106.8	95.0	103.5	140.5	143.3	-	
269.0	-	-	124.6	130.1	-	130.8	167.2	166.8	-	269.0	-	-	106.0	95.0	102.7	139.6	142.2	-	
282.2	-	-	-	126.8	-	126.8	154.3	152.9	-	282.2	-	-	103.0	95.0	-	99.9	136.0	137.8	-
295.3	-	-	-	123.5	-	122.4	141.1	138.9	-	295.3	-	-	99.2	95.0	-	97.0	132.3	133.4	-
308.4	-	-	-	119.0	-	114.0	130.1	127.5	-	305.1	-	-	96.3	95.0	-	94.6	128.1	127.0	-
311.7	-	-	-	117.4	107.4	111.9	127.3	124.9	-	308.4	-	-	-	95.0	-	93.8	126.8	124.3	-
315.0	-	-	-	115.7	107.4	109.8	124.6	122.4	-	321.5	-	-	-	94.6	-	90.1	116.4	114.1	-
321.5	-	-	-	-	105.6	105.2	119.8	117.3	-	334.6	-	-	-	93.3	-	86.9	106.7	104.1	-
334.6	-	-	-	-	99.9	96.1	110.2	107.1	-	341.2	-	-	-	91.9	78.5	85.1	102.4	99.8	-
347.8	-	-	-	-	94.6	88.0	101.0	97.9	-	347.8	-	-	-	90.6	77.8	83.3	98.2	95.5	-
354.3	-	-	-	-	92.2	84.0	96.3	93.3	-	351.1	-	-	-	89.7	77.8	82.6	96.0	93.4	-
360.9	-	-	-	-	-	80.4	92.0	88.8	-	360.9	-	-	-	-	77.8	79.1	89.9	87.3	-
374.0	-	-	-	-	-	73.2	83.6	80.5	-	374.0	-	-	-	-	77.8	73.6	82.0	79.1	-
387.1	-	-	-	-	-	66.7	75.8	72.7	-	387.1	-	-	-	-	75.0	67.1	74.7	71.8	-
400.3	-	-	-	-	-	58.8	67.0	65.3	-	393.7	-	-	-	-	73.0	63.9	71.0	68.1	-
413.4	-	-	-	-	-	49.4	56.9	54.9	-	400.3	-	-	-	-	-	60.9	67.5	64.6	-
426.5	-	-	-	-	-	40.0	46.3	44.3	-	413.4	-	-	-	-	-	54.9	60.6	57.8	-
436.4	-	-	-	-	-	36.4	40.1	37.0	-	426.5	-	-	-	-	-	48.1	54.3	51.4	-
										439.6	-	-	-	-	-	40.7	47.0	45.0	-
										452.8	-	-	-	-	-	32.6	38.4	37.9	-
										465.9	-	-	-	-	-	26.2	29.2	28.7	-
										475.7	-	-	-	-	-	21.6	23.8	21.8	-

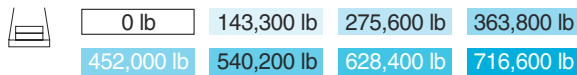

SWSL_1: 36.1 ft – 62.3 ft
 SWSL_3/SFSL_3, SWSL_4/SFSL_4: 36.1 ft – 68.9 ft
 SFSL_3 + SFSL_4: 496,100 lb + 110,200 lb

* Main boom angle 85°

Main boom angle 87°, 85°, 75°, 65° and 55°, capacities for intermediate boom positions are calculated by the crane control system IC-1

Operation

SWSL, SFSL

363,800 lb + 110,200 lb 36.1-68.9 ft										27.6 ft 32.2 ft/s 360° ASME B30.5									
275.6 ft + 275.6 ft										275.6 ft + 315.0 ft									
SWSL_1					SFSL_1	SFSL_3	SFSL_4	SWSL_1					SFSL_1	SFSL_3	SFSL_4				
0 lb					0 lb - 716,600 lb					0 lb					0 lb - 716,600 lb				
87°/85° 87°/85° 75° 65° 55°					15° 15° 15°					87°/85° 87°/85° 75° 65° 55°					15° 15° 15°				
1,000 lb										1,000 lb									
88.6	96.3	99.2	-	-	-	-	-	-	-	98.4	70.5	72.8	-	-	-	-	-	-	-
91.9	96.1	98.8	-	-	-	-	-	-	-	111.5	69.7	71.7	-	-	-	-	-	-	-
98.4	95.5	97.9	-	-	-	-	-	-	-	124.7	68.8	71.0*	-	-	-	-	-	-	-
111.5	93.3	97.4*	-	-	-	-	-	-	-	137.8	65.9	70.1*	-	-	-	-	-	-	-
124.7	83.8	96.1*	-	-	-	-	-	-	-	144.4	61.6	69.4*	-	-	-	-	-	-	-
131.2	78.7	95.2*	-	-	-	-	94.6	124.6	129.0	150.9	57.3	68.8*	-	-	-	69.0	89.9	92.2	-
137.8	73.6	94.4*	-	-	-	-	94.1	124.6	129.0	164.0	50.3	67.7*	-	-	-	68.0	88.7	91.8	-
150.9	65.0	92.6*	-	-	-	-	93.5	123.9	128.2	177.2	43.7	66.1*	-	-	-	67.2	88.0	91.1	-
164.0	57.3	90.4*	-	-	-	-	92.6	122.7	126.8	190.3	38.1	64.6*	-	-	-	66.0	86.3	89.3	-
177.2	50.9	88.2*	-	-	-	-	91.3	121.3	124.6	203.4	33.1	63.1*	-	-	-	64.6	84.7	87.5	-
190.3	45.2	85.5*	-	-	-	-	89.8	119.0	122.4	216.5	28.7	61.3*	58.0	-	-	63.3	83.1	85.5	-
200.1	41.2	83.7*	83.3	-	-	-	88.7	117.4	120.7	229.7	24.7	59.7*	58.0	-	-	61.8	81.6	83.6	-
203.4	39.9	83.1*	83.3	-	-	-	88.3	116.8	120.2	242.8	21.2	58.0*	58.0	-	-	60.3	79.9	81.7	-
216.5	35.5	80.7*	83.3	-	-	-	86.6	114.6	117.9	255.9	17.6	56.2*	58.0	-	-	58.6	78.3	79.8	-
229.7	31.3	78.0*	83.3	-	-	-	84.7	112.9	116.1	269.0	14.8	54.5*	58.0	-	-	57.1	76.7	77.7	-
242.8	27.6	75.4*	83.3	-	-	-	82.7	110.4	113.2	282.2	12.1	52.7*	58.0	-	-	55.4	74.6	75.5	-
255.9	24.3	73.0*	83.1	-	-	-	80.7	108.5	110.2	295.3	9.5	50.9*	57.8	-	-	53.8	72.1	73.4	-
269.0	21.4	70.5*	82.2	-	-	-	78.6	106.0	108.3	298.6	8.8	50.5*	57.8	-	-	53.2	71.5	72.9	-
282.2	18.5	68.3*	81.4	-	-	-	76.5	103.8	106.2	308.4	-	49.4*	57.8	-	-	52.2	69.7	71.3	-
288.7	17.4	67.2*	80.6	66.8	-	-	75.4	102.6	104.9	311.7	-	49.0*	57.8	44.1	-	51.8	69.2	70.8	-
295.3	11.5*	66.1*	79.8	66.8	-	-	74.3	101.4	103.8	321.5	-	47.8*	57.1	44.1	-	50.6	67.5	69.1	-
298.6	10.8*	65.5*	79.4	66.8	-	-	73.8	100.8	103.2	324.8	-	47.5*	56.8	44.1	-	50.3	66.9	68.6	-
308.4	-	-	78.0	66.8	-	-	72.2	99.1	101.3	334.6	-	46.3*	56.0	44.1	-	48.9	65.3	66.8	-
321.5	-	-	76.1	66.8	-	-	70.2	96.6	98.7	347.8	-	-	54.9	44.1	-	47.4	63.0	64.6	-
334.6	-	-	73.9	66.8	-	-	68.1	94.4	96.3	360.9	-	-	53.8	44.1	-	45.6	60.8	62.5	-
344.5	-	-	72.1	66.8	-	-	66.1	91.7	92.6	374.0	-	-	52.5	44.1	-	44.1	58.4	60.4	-
347.8	-	-	-	66.8	-	-	65.5	90.8	91.3	383.9	-	-	51.6	44.1	-	42.9	56.2	57.8	-
360.9	-	-	-	66.8	-	-	63.2	86.3	85.2	387.1	-	-	-	44.1	-	42.5	55.6	57.0	-
367.5	-	-	-	66.8	53.6	-	62.0	83.3	81.5	397.0	-	-	-	44.1	33.5	41.2	53.6	54.7	-
374.0	-	-	-	66.8	53.6	-	60.8	80.0	77.8	400.3	-	-	-	44.1	33.5	40.8	52.9	53.9	-
387.1	-	-	-	66.1	53.6	-	57.9	73.1	70.8	413.4	-	-	-	44.1	33.5	38.8	50.3	50.7	-
390.4	-	-	-	66.1	53.6	-	57.3	71.4	69.0	426.5	-	-	-	44.1	33.5	37.3	47.6	47.6	-
400.3	-	-	-	-	53.6	-	55.5	66.4	64.0	439.6	-	-	-	-	33.3	35.1	44.4	43.5	-
413.4	-	-	-	-	53.1	-	53.1	59.7	57.5	452.8	-	-	-	-	33.3	33.3	40.6	38.4	-
426.5	-	-	-	-	53.1	-	48.9	53.7	51.4	465.9	-	-	-	-	33.3	31.4	35.4	33.1	-
433.1	-	-	-	-	53.1	-	46.7	50.7	48.3	469.2	-	-	-	-	33.3	30.9	34.1	31.9	-
439.6	-	-	-	-	-	-	44.2	47.8	45.4	479.0	-	-	-	-	-	29.1	30.5	28.2	-
452.8	-	-	-	-	-	-	39.0	42.1	39.7	492.1	-	-	-	-	-	24.5	25.8	23.4	-
465.9	-	-	-	-	-	-	32.0	36.8	34.2	518.4	-	-	-	-	-	11.9	15.9	13.9	-
479.0	-	-	-	-	-	-	24.9	31.0	28.5	528.2	-	-	-	-	-	9.0	11.4	9.9	-
492.1	-	-	-	-	-	-	18.1	23.6	22.5	531.5	-	-	-	-	-	-	9.9	-	-
511.8	-	-	-	-	-	-	10.1	11.7	10.4										

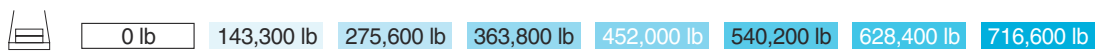

SWSL_1: 36.1 ft – 62.3 ft
 SWSL_3/SFSL_3, SWSL_4/SFSL_4: 36.1 ft – 68.9 ft
 SFSL_3 + SFSL_4: 496,100 lb + 110,200 lb

* Main boom angle 85°
 Main boom angle 87°, 85°, 75°, 65° and 55°, capacities for intermediate boom positions are calculated by the crane control system IC-1

Operation

SWSL, SFSL

363,800 lb + 110,200 lb 36.1-68.9 ft										27.6 ft 32.2 ft/s 360° ASME B30.5									
295.3 ft + 78.7 ft										295.3 ft + 118.1 ft									
SWSL_1					SFSL_1	SFSL_3	SFSL_4	SWSL_1					SFSL_1	SFSL_3	SFSL_4				
0 lb					0 lb - 716,600 lb					0 lb					0 lb - 716,600 lb				
87°/85° 87°/85° 75° 65° 55°					15° 15° 15°					87°/85° 87°/85° 75° 65° 55°					15° 15° 15°				
1,000 lb										1,000 lb									
45.9	310.9	346.1	-	-	-	-	-	-	-	55.8	246.9	264.6	-	-	-	-	-	-	-
52.5	280.0	337.3	-	-	-	-	-	-	-	59.1	235.9	260.1	-	-	-	-	-	-	-
59.1	253.5	348.3*	-	-	-	-	-	-	-	65.6	215.0	255.7	-	-	-	-	-	-	-
65.6	231.5	339.5*	-	-	-	-	337.3	-	-	72.2	198.4	262.4*	-	-	-	-	-	-	-
72.2	215.0	330.7*	-	-	-	-	335.1	445.3	476.2	78.7	183.0	257.9*	-	-	-	255.7	-	-	-
78.7	198.4	319.7*	-	-	-	-	335.1	445.3	474.0	85.3	170.9	251.3*	-	-	-	253.5	343.9	363.8	-
85.3	185.2	310.9*	-	-	-	-	332.9	438.7	471.8	91.9	158.7	246.9*	-	-	-	253.5	343.9	363.8	-
91.9	173.1	299.8*	-	-	-	-	330.7	438.7	471.8	98.4	148.8	240.3*	-	-	-	253.5	343.9	361.6	-
98.4	163.1	288.8*	-	-	-	-	328.5	434.3	467.4	111.5	132.3	227.1*	-	-	-	250.6	337.3	359.4	-
108.3	136.7*	277.8*	-	-	-	-	324.1	427.7	458.6	124.7	117.9	213.8*	-	-	-	246.9	332.9	354.9	-
111.5	-	-	-	-	-	-	322.6	427.7	458.6	137.8	107.4	202.8*	-	-	-	242.5	332.9	354.9	-
124.7	-	-	317.5	-	-	-	315.3	420.3	442.4	141.1	95.2*	201.0*	240.3	-	-	241.0	327.0	350.5	-
137.8	-	-	302.0	-	-	-	306.4	410.1	410.1	147.6	90.8*	197.3*	235.9	-	-	238.1	326.3	346.1	-
150.9	-	-	284.4	-	-	-	297.6	368.9	367.4	150.9	-	-	233.7	-	-	236.6	326.3	343.9	-
160.8	-	-	269.0	-	-	-	287.7	339.9	337.7	164.0	-	-	224.9	-	-	230.8	318.2	326.3	-
164.0	-	-	-	-	-	-	284.4	331.4	329.2	177.2	-	-	215.0	-	-	224.9	302.0	299.8	-
177.2	-	-	-	-	-	-	271.2	297.6	295.4	190.3	-	-	202.8	-	-	216.8	274.1	271.9	-
187.0	-	-	-	251.3	-	-	251.3	276.7	274.5	196.9	-	-	196.2	-	-	212.7	260.1	257.9	-
190.3	-	-	-	244.7	-	-	244.7	269.7	267.5	203.4	-	-	-	-	-	208.7	248.4	246.5	-
203.4	-	-	-	227.1	-	-	220.8	244.0	240.3	206.7	-	-	-	202.8	-	206.7	242.5	240.7	-
206.7	-	-	-	222.7	-	-	215.5	238.1	235.1	216.5	-	-	-	199.5	-	200.6	224.9	222.7	-
216.5	-	-	-	-	-	-	199.5	222.7	219.4	229.7	-	-	-	189.6	-	184.5	206.5	204.3	-
229.7	-	-	-	-	-	-	181.9	203.6	201.0	242.8	-	-	-	178.6	-	169.0	189.2	187.0	-
242.8	-	-	-	-	166.4	-	165.7	185.9	183.7	246.1	-	-	-	176.4	-	165.3	185.2	183.0	-
252.6	-	-	-	-	158.7	-	154.7	173.8	171.6	255.9	-	-	-	-	-	154.3	173.1	170.9	-
255.9	-	-	-	-	-	-	151.0	169.8	167.6	269.0	-	-	-	-	141.1	141.5	159.1	156.9	-
269.0	-	-	-	-	-	-	138.5	155.8	153.6	282.2	-	-	-	-	133.4	129.7	146.2	143.3	-
282.2	-	-	-	-	-	-	126.4	143.5	140.0	292.0	-	-	-	-	127.9	120.9	137.4	134.2	-
295.3	-	-	-	-	-	-	114.6	131.2	126.8	295.3	-	-	-	-	-	117.9	134.5	131.2	-
308.4	-	-	-	-	-	-	105.2	116.9	113.7	308.4	-	-	-	-	-	108.0	122.7	119.4	-
321.5	-	-	-	-	-	-	93.3	101.9	99.2	321.5	-	-	-	-	-	98.5	111.7	108.2	-
334.6	-	-	-	-	-	-	78.7	86.0	83.3	334.6	-	-	-	-	-	89.5	101.4	97.7	-
337.9	-	-	-	-	-	-	75.2	82.2	79.4	347.8	-	-	-	-	-	80.4	89.8	87.0	-
										360.9	-	-	-	-	-	69.7	76.9	74.5	-
										374.0	-	-	-	-	-	57.5	63.7	61.3	-
										377.3	-	-	-	-	-	55.3	60.8	58.0	-

SWSL_1: 36.1 ft – 62.3 ft
 SWSL_3/SFSL_3, SWSL_4/SFSL_4: 36.1 ft – 68.9 ft
 SFSL_3 + SFSL_4: 496,100 lb + 110,200 lb

* Main boom angle 85°
 Main boom angle 87°, 85°, 75°, 65° and 55°, capacities for intermediate boom positions are calculated by the crane control system IC-1

Operation

SWSL, SFSL

363,800 lb + 110,200 lb 36.1-68.9 ft										27.6 ft 32.2 ft/s 360° ASME B30.5																													
295.3 ft + 157.5 ft					SWSL_1					SFSL_1	SFSL_3	SFSL_4	295.3 ft + 196.9 ft					SWSL_1					SFSL_1	SFSL_3	SFSL_4														
0 lb					0 lb - 716,600 lb					0 lb					0 lb - 716,600 lb					0 lb					0 lb - 716,600 lb														
87°/85° 87°/85° 75° 65° 55°					15° 15° 15°					87°/85° 87°/85° 75° 65° 55°					15° 15° 15°					87°/85° 87°/85° 75° 65° 55°					15° 15° 15°														
ft										1,000 lb										ft										1,000 lb									
62.3	198.4	203.9	-	-	-	-	-	-	-	72.2	152.1	155.4	-	-	-	-	-	-	-	78.7	149.9	153.2	-	-	-	-	-	-	-	-									
65.6	196.2	202.8	-	-	-	-	-	-	-	85.3	144.4	152.1	-	-	-	-	-	-	-	91.9	134.5	154.3*	-	-	-	-	-	-	-	-									
72.2	183.0	199.5	-	-	-	-	-	-	-	98.4	125.7	152.1*	-	-	-	-	-	-	-	98.4	125.7	152.1*	-	-	-	-	-	-	-	-									
78.7	168.7	203.9*	-	-	-	-	-	-	-	105.0	117.9	149.9*	-	-	-	-	-	-	-	105.0	117.9	149.9*	-	-	-	148.8	203.9	212.7	-	-									
85.3	156.5	200.6*	-	-	-	-	-	-	-	111.5	110.2	147.7*	-	-	-	-	-	-	-	111.5	110.2	147.7*	-	-	-	148.3	203.9	212.7	-	-									
91.9	146.6	198.4*	-	-	-	-	-	-	-	124.7	97.9	143.3*	-	-	-	-	-	-	-	124.7	97.9	143.3*	-	-	-	147.3	203.9	212.4	-	-									
98.4	136.7	194.0*	-	-	-	-	-	-	-	137.8	87.3	137.8*	-	-	-	-	-	-	-	137.8	87.3	137.8*	-	-	-	146.6	203.9	211.6	-	-									
111.5	120.2	186.3*	-	-	-	-	-	-	-	150.9	78.3	132.3*	-	-	-	-	-	-	-	150.9	78.3	132.3*	-	-	-	144.4	201.4	209.4	-	-									
124.7	107.4	178.6*	-	-	-	-	-	-	-	164.0	70.5	127.9*	-	-	-	-	-	-	-	164.0	70.5	127.9*	-	-	-	142.2	199.5	206.9	-	-									
137.8	96.1	169.8*	-	-	-	-	-	-	-	173.9	65.4	123.7*	137.8	-	-	-	-	-	-	173.9	65.4	123.7*	137.8	-	-	140.5	197.9	204.7	-	-									
150.9	86.9	162.0*	-	-	-	-	-	-	-	177.2	63.7	122.4*	137.8	-	-	-	-	-	-	177.2	63.7	122.4*	137.8	-	-	140.0	197.3	203.9	-	-									
154.2	84.9	160.1*	184.1	-	-	-	-	-	-	190.3	57.8	116.8*	136.7	-	-	-	-	-	-	190.3	57.8	116.8*	136.7	-	-	136.5	193.3	200.3	-	-									
164.0	78.9	154.3*	183.0	-	-	-	-	-	-	203.4	52.7	112.4*	133.4	-	-	-	-	-	-	203.4	52.7	112.4*	133.4	-	-	133.0	190.0	196.6	-	-									
173.9	73.9	149.4*	179.7	-	-	-	-	-	-	213.3	49.4	109.1*	131.2	-	-	-	-	-	-	213.3	49.4	109.1*	131.2	-	-	130.8	187.2	193.8	-	-									
177.2	64.2*	147.7*	178.6	-	-	-	-	-	-	216.5	41.4*	108.0*	130.1	-	-	-	-	-	-	216.5	41.4*	108.0*	130.1	-	-	130.1	186.3	192.9	-	-									
183.7	61.5*	145.5*	175.8	-	-	-	-	-	-	223.1	39.5*	106.3*	127.9	-	-	-	-	-	-	223.1	39.5*	106.3*	127.9	-	-	127.9	183.4	189.2	-	-									
190.3	-	-	173.1	-	-	-	-	-	-	229.7	-	-	125.7	-	-	-	-	-	-	229.7	-	-	125.7	-	-	125.7	179.7	185.2	-	-									
203.4	-	-	166.4	-	-	-	-	-	-	242.8	-	-	121.3	-	-	-	-	-	-	242.8	-	-	121.3	-	-	121.6	171.6	176.4	-	-									
216.5	-	-	159.8	-	-	-	-	-	-	252.6	-	-	117.9	114.6	-	-	-	-	-	252.6	-	-	117.9	114.6	-	118.9	166.1	169.8	-	-									
229.7	-	-	152.1	151.0	-	-	-	-	-	255.9	-	-	116.8	114.6	-	-	-	-	-	255.9	-	-	116.8	114.6	-	117.9	164.2	167.6	-	-									
236.2	-	-	148.8	149.9	-	-	-	-	-	269.0	-	-	113.3	114.6	-	-	-	-	-	269.0	-	-	113.3	114.6	-	113.5	156.2	155.8	-	-									
242.8	-	-	148.8	148.8	-	-	-	-	-	272.3	-	-	109.8	113.8	-	-	-	-	-	272.3	-	-	109.8	113.8	-	112.4	154.1	152.9	-	-									
255.9	-	-	144.4	144.4	-	-	-	-	-	282.2	-	-	111.3	113.8	-	-	-	-	-	282.2	-	-	111.3	113.8	-	109.6	145.9	143.7	-	-									
269.0	-	-	137.8	137.8	-	-	-	-	-	285.4	-	-	108.7	113.8	-	-	-	-	-	285.4	-	-	108.7	113.8	-	106.3	133.4	131.2	-	-									
282.2	-	-	131.2	131.2	-	-	-	-	-	295.3	-	-	104.1	113.8	-	-	-	-	-	295.3	-	-	104.1	113.8	-	101.3	121.5	119.4	-	-									
285.4	-	-	129.0	129.0	-	-	-	-	-	308.4	-	-	98.8	113.8	-	-	-	-	-	308.4	-	-	98.8	113.8	-	96.6	111.3	108.8	-	-									
295.3	-	-	120.2	120.2	-	-	-	-	-	321.5	-	-	91.7	113.8	-	-	-	-	-	321.5	-	-	91.7	113.8	-	91.9	102.3	99.4	-	-									
298.6	-	-	116.8	116.8	-	-	-	-	-	324.8	-	-	89.1	113.8	-	-	-	-	-	324.8	-	-	89.1	113.8	-	85.1	93.3	90.4	-	-									
308.4	-	-	112.4	112.4	-	-	-	-	-	334.6	-	-	84.7	113.8	-	-	-	-	-	334.6	-	-	84.7	113.8	-	77.5	84.7	81.9	-	-									
321.5	-	-	106.5	106.5	-	-	-	-	-	347.8	-	-	82.5	113.8	-	-	-	-	-	347.8	-	-	82.5	113.8	-	73.9	80.6	77.7	-	-									
328.1	-	-	103.6	103.6	-	-	-	-	-	360.9	-	-	82.5	113.8	-	-	-	-	-	360.9	-	-	82.5	113.8	-	70.3	76.5	73.6	-	-									
334.6	-	-	91.7	91.7	-	-	-	-	-	374.0	-	-	82.5	113.8	-	-	-	-	-	374.0	-	-	82.5	113.8	-	63.6	69.0	65.8	-	-									
347.8	-	-	83.6	83.6	-	-	-	-	-	387.1	-	-	82.5	113.8	-	-	-	-	-	387.1	-	-	82.5	113.8	-	57.1	61.8	58.7	-	-									
360.9	-	-	76.0	76.0	-	-	-	-	-	400.3	-	-	82.5	113.8	-	-	-	-	-	400.3	-	-	82.5	113.8	-	50.5	54.9	51.8	-	-									
374.0	-	-	68.8	68.8	-	-	-	-	-	413.4	-	-	82.5	113.8	-	-	-	-	-	413.4	-	-	82.5	113.8	-	41.9	48.1	45.2	-	-									
387.1	-	-	60.0	60.0	-	-	-	-	-	426.5	-	-	82.5	113.8	-	-	-	-	-	426.5	-	-	82.5	113.8	-	33.0	38.4	37.0	-	-									
400.3	-	-	50.0	50.0	-	-	-	-	-	439.6	-	-	82.5	113.8	-	-	-	-	-	439.6	-	-	82.5	113.8	-	27.3	28.7	27.3	-	-									
413.4	-	-	40.8	40.8	-	-	-	-	-	452.8	-	-	82.5	113.8	-	-	-	-	-	452.8	-	-	82.5	113.8	-	27.3	28.7	27.3	-	-									
416.7	-	-	39.5	39.5	-	-	-	-	-																														

0 lb 143,300 lb 275,600 lb 363,800 lb 452,000 lb 540,200 lb 628,400 lb 716,600 lb

SWSL_1: 36.1 ft – 62.3 ft

SWSL_3/SFSL_3, SWSL_4/SFSL_4: 36.1 ft – 68.9 ft

SFSL_3 + SFSL_4: 496,100 lb + 110,200 lb

* Main boom angle 85°

Main boom angle 87°, 85°, 75°, 65° and 55°, capacities for intermediate boom positions are calculated by the crane control system IC-1

Operation

SWSL, SFSL

363,800 lb + 110,200 lb 36.1-68.9 ft										27.6 ft 32.2 ft/s 360° ASME B30.5									
295.3 ft + 236.2 ft										295.3 ft + 275.6 ft									
SWSL_1					SFSL_1	SFSL_3	SFSL_4	SWSL_1					SFSL_1	SFSL_3	SFSL_4				
0 lb					0 lb - 716,600 lb					0 lb					0 lb - 716,600 lb				
87°/85° 87°/85° 75° 65° 55°					15° 15° 15°					87°/85° 87°/85° 75° 65° 55°					15° 15° 15°				
ft										ft									
1,000 lb										1,000 lb									
82.0	115.7	119.0	-	-	-	-	-	-	-	88.6	88.0	90.8	-	-	-	-	-	-	-
85.3	115.7	119.0	-	-	-	-	-	-	-	91.9	87.7	90.4	-	-	-	-	-	-	-
91.9	114.6	116.8	-	-	-	-	-	-	-	98.4	87.1	89.3	-	-	-	-	-	-	-
98.4	112.4	117.9*	-	-	-	-	-	-	-	111.5	85.8	89.1*	-	-	-	-	-	-	-
111.5	101.0	116.8*	-	-	-	-	-	-	-	124.7	79.6	87.7*	-	-	-	-	-	-	-
118.1	94.9	115.2*	-	-	-	113.5	154.3	160.9	-	131.2	74.6	86.9*	-	-	85.8	115.7	120.2	-	
124.7	88.8	113.5*	-	-	-	113.5	154.3	160.9	-	137.8	69.7	86.0*	-	-	85.5	115.7	120.2	-	
137.8	78.5	110.2*	-	-	-	113.5	154.3	160.9	-	150.9	61.5	84.0*	-	-	84.8	115.1	119.5	-	
150.9	69.9	107.8*	-	-	-	112.1	153.6	159.5	-	164.0	54.2	81.8*	-	-	83.9	114.3	118.3	-	
164.0	62.4	104.3*	-	-	-	110.5	152.1	157.6	-	177.2	47.8	79.6*	-	-	82.9	113.5	116.8	-	
177.2	55.8	100.8*	-	-	-	108.9	149.9	155.4	-	190.3	42.3	77.2*	-	-	81.4	111.3	115.4	-	
190.3	50.0	97.0*	103.4	-	-	107.1	148.4	153.2	-	203.4	37.5	74.5*	-	-	79.9	109.6	113.5	-	
203.4	45.0	93.3*	103.4	-	-	104.9	146.2	151.0	-	206.7	36.4	73.9*	75.2	-	-	79.5	109.2	113.0	
216.5	40.6	89.7*	103.2	-	-	102.5	143.3	148.8	-	216.5	33.1	72.1*	75.2	-	-	78.3	108.2	111.3	
229.7	36.4	86.4*	101.6	-	-	100.0	140.7	145.5	-	229.7	29.1	69.7*	75.2	-	-	76.4	106.3	109.2	
242.8	32.8	83.1*	99.2	-	-	97.4	137.4	141.5	-	242.8	25.6	67.0*	75.2	-	-	74.4	104.1	107.1	
249.3	31.3	81.7*	98.1	-	-	96.0	136.0	139.6	-	255.9	22.3	64.6*	74.7	-	-	72.5	101.9	104.7	
255.9	23.8*	80.2*	97.0	-	-	94.6	134.5	137.8	-	269.0	19.4	62.4*	73.4	-	-	70.5	99.4	102.4	
259.2	23.1*	79.6*	96.3	-	-	93.9	133.6	136.9	-	282.2	16.8	60.2*	72.1	-	-	68.3	97.3	100.0	
269.0	-	-	94.1	-	-	91.8	130.8	134.1	-	288.7	15.7	59.2*	71.2	-	-	67.2	96.2	98.8	
275.6	-	-	92.5	84.4	-	90.4	129.0	132.3	-	295.3	9.0*	58.2*	70.3	-	-	66.1	95.0	97.7	
282.2	-	-	90.8	84.4	-	88.9	127.2	130.1	-	298.6	-	57.5*	69.8	59.1	-	65.6	94.5	97.1	
295.3	-	-	87.5	84.4	-	86.0	123.5	125.7	-	308.4	-	-	68.3	59.1	-	64.1	93.0	95.3	
308.4	-	-	84.0	84.4	-	83.0	117.6	117.6	-	321.5	-	-	66.4	59.1	-	61.9	90.8	93.0	
311.7	-	-	82.9	84.0	-	82.3	116.1	115.6	-	334.6	-	-	64.2	59.1	-	59.7	88.6	90.8	
321.5	-	-	-	82.9	-	79.9	109.9	108.4	-	347.8	-	-	61.7	59.1	-	57.6	86.5	87.1	
334.6	-	-	-	-	80.9	76.9	100.3	98.1	-	351.1	-	-	61.1	59.1	-	57.1	86.0	85.1	
347.8	-	-	-	-	78.0	72.9	91.8	89.5	-	360.9	-	-	-	59.1	-	55.1	81.1	79.4	
354.3	-	-	-	-	76.2	71.2	87.7	85.5	-	374.0	-	-	-	57.8	-	52.5	73.9	71.9	
360.9	-	-	-	-	74.3	69.4	83.9	81.6	-	380.6	-	-	-	57.3	45.6	51.2	70.4	68.3	
374.0	-	-	-	-	-	65.9	76.3	73.9	-	387.1	-	-	-	56.4	45.6	50.0	67.0	65.0	
387.1	-	-	-	-	-	62.4	69.0	66.4	-	397.0	-	-	-	54.7	45.6	47.8	62.1	60.1	
400.3	-	-	-	-	-	57.8	62.1	59.5	-	400.3	-	-	-	-	45.6	47.0	60.6	58.5	
403.5	-	-	-	-	-	56.4	60.4	57.8	-	413.4	-	-	-	-	45.6	44.3	54.2	52.0	
413.4	-	-	-	-	-	52.2	55.3	52.7	-	426.5	-	-	-	-	45.0	41.7	48.3	46.0	
426.5	-	-	-	-	-	46.7	48.9	46.3	-	439.6	-	-	-	-	44.3	38.9	42.4	40.1	
439.6	-	-	-	-	-	40.6	43.0	40.3	-	442.9	-	-	-	-	43.7	38.1	41.0	38.7	
452.8	-	-	-	-	-	33.7	37.3	34.6	-	452.8	-	-	-	-	-	35.9	36.8	34.4	
465.9	-	-	-	-	-	26.1	31.5	28.8	-	465.9	-	-	-	-	-	30.8	31.6	29.1	
479.0	-	-	-	-	-	19.4	23.7	21.8	-	479.0	-	-	-	-	-	24.3	26.7	24.0	
492.1	-	-	-	-	-	13.9	15.2	13.2	-	492.1	-	-	-	-	-	17.6	21.8	19.2	
										511.8	-	-	-	-	-	9.0	13.7	11.9	
										515.1	-	-	-	-	-	-	11.8	9.9	
										518.4	-	-	-	-	-	-	9.9	-	



* Main boom angle 85°
 Main boom angle 87°, 85°, 75°, 65° and 55°, capacities for intermediate boom positions are calculated by the crane control system IC-1

Operation

SWSL, SFSL

363,800 lb + 110,200 lb 36.1-68.9 ft										27.6 ft 32.2 ft/s 360° ASME B30.5									
295.3 ft + 315.0 ft										315.0 ft + 78.7 ft									
SWSL_1					SFSL_1	SFSL_3	SFSL_4	SWSL_1					SFSL_1	SFSL_3	SFSL_4				
0 lb					0 lb - 716,600 lb					0 lb					0 lb - 716,600 lb				
87°/85° 87°/85° 75° 65° 55°					15° 15° 15°					87°/85° 87°/85° 75° 65° 55°					15° 15° 15°				
1,000 lb										1,000 lb									
98.4	63.9	66.1	-	-	-	-	-	-	-	45.9	-	310.9	-	-	-	-	-	-	-
111.5	63.1	65.0	-	-	-	-	-	-	-	49.2	282.2	306.4	-	-	-	-	-	-	-
124.7	62.2	64.4*	-	-	-	-	-	-	-	52.5	266.8	304.2	-	-	-	-	-	-	-
137.8	60.0	63.5*	-	-	-	-	-	-	-	59.1	242.5	308.6*	-	-	-	-	-	-	-
147.6	55.0	62.5*	-	-	-	-	62.2	83.8	-	65.6	222.7	304.2*	-	-	-	299.8	-	-	-
150.9	53.4	62.2*	-	-	-	-	61.9	83.6	-	72.2	205.0	297.6*	-	-	-	299.8	410.1	440.9	-
154.2	51.6	61.8*	-	-	-	-	61.7	83.5	86.6	78.7	190.7	288.8*	-	-	-	297.6	410.1	436.5	-
164.0	46.3	60.8*	-	-	-	-	61.2	83.1	86.3	85.3	177.5	280.0*	-	-	-	295.4	407.9	436.5	-
177.2	40.3	59.5*	-	-	-	-	60.6	82.7	85.8	91.9	166.4	271.2*	-	-	-	295.4	405.7	434.3	-
190.3	35.1	58.0*	-	-	-	-	59.5	81.5	84.4	98.4	156.5	262.4*	-	-	-	291.0	405.7	434.3	-
203.4	30.2	56.2*	-	-	-	-	58.2	80.2	82.9	111.5	126.8*	249.1*	-	-	-	285.1	396.8	424.0	-
216.5	26.0	54.7*	-	-	-	-	56.9	78.7	81.1	124.7	-	-	-	-	-	278.5	389.5	412.3	-
223.1	24.0	53.8*	51.8	-	-	-	56.2	78.1	80.2	128.0	-	-	280.0	-	-	276.7	389.1	407.9	-
229.7	22.0	52.9*	51.8	-	-	-	55.6	77.3	79.4	137.8	-	-	271.2	-	-	271.2	388.0	394.6	-
242.8	18.5	51.1*	51.8	-	-	-	54.2	75.8	77.5	150.9	-	-	255.7	-	-	262.4	358.6	359.4	-
255.9	15.4	49.4*	51.8	-	-	-	52.7	73.9	75.6	164.0	-	-	238.1	-	-	252.8	327.0	324.1	-
269.0	12.6	47.6*	51.8	-	-	-	51.1	72.1	73.7	177.2	-	-	-	-	-	242.5	293.2	288.8	-
282.2	9.9	45.9*	51.6	-	-	-	49.5	70.3	71.8	190.3	-	-	-	-	-	231.5	265.3	262.4	-
285.4	9.3	45.4*	51.4	-	-	-	49.1	69.8	71.3	193.6	-	-	-	227.1	-	229.3	258.3	255.7	-
295.3	-	44.1*	50.9	-	-	-	47.8	68.3	69.9	203.4	-	-	-	218.3	-	217.2	239.2	237.7	-
308.4	-	42.5*	50.3	-	-	-	46.3	66.6	68.0	216.5	-	-	-	202.8	-	197.3	217.2	215.0	-
318.2	-	41.4*	49.8	38.1	-	-	45.0	65.3	66.5	229.7	-	-	-	-	-	179.7	198.0	195.8	-
321.5	-	41.0*	49.6	38.1	-	-	44.6	64.8	66.1	242.8	-	-	-	-	-	163.4	180.4	178.2	-
324.8	-	40.6*	49.3	38.1	-	-	44.3	64.4	65.6	252.6	-	-	-	-	153.2	152.1	168.3	166.1	-
334.6	-	39.5*	48.5	38.1	-	-	43.0	63.1	64.2	255.9	-	-	-	-	149.9	148.8	164.2	162.0	-
337.9	-	39.2*	48.2	38.1	-	-	42.6	62.4	63.7	262.5	-	-	-	-	145.5	142.2	157.6	154.7	-
347.8	-	-	47.2	38.1	-	-	41.4	61.1	62.2	269.0	-	-	-	-	-	135.6	151.0	147.7	-
360.9	-	-	45.9	38.1	-	-	39.8	59.3	60.4	282.2	-	-	-	-	-	123.1	138.2	134.8	-
374.0	-	-	44.3	38.1	-	-	38.1	57.5	58.4	295.3	-	-	-	-	-	111.3	125.7	122.4	-
387.1	-	-	43.0	38.1	-	-	36.4	55.3	55.7	308.4	-	-	-	-	-	101.8	114.3	110.7	-
400.3	-	-	-	38.1	-	-	34.4	51.8	52.2	321.5	-	-	-	-	-	92.2	102.4	99.5	-
410.1	-	-	-	38.1	27.6	-	33.1	49.2	49.3	334.6	-	-	-	-	-	82.7	89.1	86.4	-
413.4	-	-	-	38.1	27.6	32.6	48.3	48.3	-	347.8	-	-	-	-	-	69.3	74.7	72.2	-
426.5	-	-	-	37.5	27.3	30.7	44.8	43.4	-	357.6	-	-	-	-	-	59.3	64.8	61.3	-
436.4	-	-	-	36.8	27.3	29.3	41.7	39.6	-										
439.6	-	-	-	-	27.3	28.7	40.3	38.3	-										
452.8	-	-	-	-	27.3	26.2	35.1	32.8	-										
465.9	-	-	-	-	27.3	24.4	30.0	27.9	-										
479.0	-	-	-	-	27.3	22.2	25.2	22.9	-										
482.3	-	-	-	-	26.9	21.6	24.0	21.7	-										
492.1	-	-	-	-	-	19.8	20.5	18.1	-										
518.4	-	-	-	-	-	9.3	11.8	9.3	-										
524.9	-	-	-	-	-	-	9.7	-	-										

* Main boom angle 85°

Main boom angle 87°, 85°, 75°, 65° and 55°, capacities for intermediate boom positions are calculated by the crane control system IC-1

SWSL_1: 36.1 ft – 62.3 ft
 SWSL_3/SFSL_3, SWSL_4/SFSL_4: 36.1 ft – 68.9 ft
 SFSL_3 + SFSL_4: 496,100 lb + 110,200 lb

Operation

SWSL, SFSL

363,800 lb + 110,200 lb 36.1-68.9 ft										27.6 ft 32.2 ft/s 360° ASME B30.5									
315.0 ft + 118.1 ft										315.0 ft + 157.5 ft									
SWSL_1					SFSL_1	SFSL_3	SFSL_4	SWSL_1					SFSL_1	SFSL_3	SFSL_4				
0 lb					0 lb - 716,600 lb					0 lb					0 lb - 716,600 lb				
87°/85° 87°/85° 75° 65° 55°					15° 15° 15°					87°/85° 87°/85° 75° 65° 55°					15° 15° 15°				
ft										1,000 lb									
55.8	229.3	238.1	-	-	-	-	-	-	-	65.6	179.7	184.1	-	-	-	-	-	-	-
59.1	224.9	235.9	-	-	-	-	-	-	-	72.2	174.2	180.8	-	-	-	-	-	-	-
65.6	206.1	229.3	-	-	-	-	-	-	-	78.7	160.9	177.5	-	-	-	-	-	-	-
72.2	189.6	235.9*	-	-	-	-	-	-	-	85.3	149.9	181.9*	-	-	-	-	-	-	-
78.7	175.3	231.5*	-	-	-	-	-	-	-	91.9	140.0	179.7*	-	-	-	-	-	-	-
82.0	169.2	229.3*	-	-	-	-	227.1	-	-	95.1	135.0	178.0*	-	-	-	176.4	-	-	-
85.3	163.1	227.1*	-	-	-	-	227.1	-	-	98.4	130.1	176.4*	-	-	-	175.3	-	-	-
88.6	157.6	223.8*	-	-	-	-	227.1	319.7	339.5	101.7	126.2	174.4*	-	-	-	175.1	249.1	264.6	-
91.9	152.1	220.5*	-	-	-	-	227.1	319.7	339.5	111.5	114.6	168.7*	-	-	-	174.5	249.1	264.6	-
98.4	143.3	216.1*	-	-	-	-	224.9	319.7	337.3	124.7	102.7	160.9*	-	-	-	172.7	246.9	262.4	-
111.5	126.8	203.9*	-	-	-	-	221.9	315.3	335.1	137.8	91.9	153.2*	-	-	-	169.8	246.9	262.4	-
124.7	113.5	192.9*	-	-	-	-	218.6	308.6	330.7	150.9	83.1	146.6*	-	-	-	166.8	244.7	257.9	-
137.8	103.0	183.0*	-	-	-	-	215.0	308.6	330.7	160.8	77.3	141.6*	164.2	-	-	164.4	241.4	255.0	-
144.4	88.0*	179.3*	212.7	-	-	-	212.0	305.0	324.1	164.0	75.4	140.0*	163.1	-	-	163.5	240.3	254.3	-
147.6	85.8*	177.5*	211.6	-	-	-	210.5	304.2	321.9	173.9	70.3	135.0*	160.9	-	-	160.8	240.3	252.1	-
150.9	-	-	210.5	-	-	-	209.1	303.5	319.7	177.2	60.4*	133.4*	159.8	-	-	159.8	240.3	251.3	-
164.0	-	-	201.7	-	-	-	203.2	296.2	306.4	187.0	56.2*	130.1*	155.7	-	-	156.5	235.9	246.9	-
177.2	-	-	191.8	-	-	-	197.3	284.4	288.8	190.3	-	-	154.3	-	-	155.4	235.2	245.4	-
190.3	-	-	181.9	-	-	-	190.0	265.3	265.3	203.4	-	-	148.8	-	-	150.6	228.4	234.6	-
203.4	-	-	170.9	-	-	-	182.6	244.7	241.8	216.5	-	-	142.2	-	-	145.5	218.3	218.3	-
216.5	-	-	-	175.3	-	-	175.3	222.7	219.4	229.7	-	-	135.6	-	-	140.4	202.8	201.4	-
229.7	-	-	-	167.6	-	-	166.8	203.6	200.3	239.5	-	-	130.1	130.1	-	136.3	191.1	188.9	-
242.8	-	-	-	158.7	-	-	159.5	185.9	182.6	242.8	-	-	-	130.1	-	134.8	187.0	184.8	-
255.9	-	-	-	147.7	-	-	152.1	169.8	166.4	255.9	-	-	-	125.7	-	129.0	170.9	168.7	-
269.0	-	-	-	-	-	-	138.9	155.8	152.3	269.0	-	-	-	120.2	-	123.1	156.9	154.7	-
282.2	-	-	-	-	-	126.8	126.4	142.2	138.9	282.2	-	-	-	113.5	-	117.2	143.3	140.0	-
295.3	-	-	-	-	-	119.0	114.6	129.0	125.7	292.0	-	-	-	108.9	-	112.8	133.4	130.1	-
301.8	-	-	-	-	-	115.7	109.7	123.1	120.0	295.3	-	-	-	-	-	111.3	130.1	126.8	-
308.4	-	-	-	-	-	-	104.8	117.2	114.3	308.4	-	-	-	-	-	100.5	104.6	119.0	115.7
321.5	-	-	-	-	-	-	95.2	106.3	103.4	321.5	-	-	-	-	96.6	96.5	108.6	105.4	-
334.6	-	-	-	-	-	-	86.4	96.3	92.8	334.6	-	-	-	-	91.3	87.5	98.8	95.7	-
347.8	-	-	-	-	-	-	78.5	86.9	83.4	341.2	-	-	-	-	88.4	83.5	93.9	91.0	-
360.9	-	-	-	-	-	-	70.5	77.2	74.2	347.8	-	-	-	-	-	79.4	89.4	86.3	-
374.0	-	-	-	-	-	-	60.2	67.2	63.7	360.9	-	-	-	-	-	71.7	80.6	77.4	-
387.1	-	-	-	-	-	-	49.2	55.0	51.7	374.0	-	-	-	-	-	64.8	72.1	69.0	-
393.7	-	-	-	-	-	-	44.3	48.9	45.6	387.1	-	-	-	-	-	58.2	64.4	61.2	-
										400.3	-	-	-	-	-	50.3	55.8	53.1	-
										413.4	-	-	-	-	-	40.8	46.1	43.9	-
										426.5	-	-	-	-	-	31.6	35.6	33.6	-
										433.1	-	-	-	-	-	29.1	30.4	28.4	-

SWSL_1: 36.1 ft – 62.3 ft
 SWSL_3/SFSL_3, SWSL_4/SFSL_4: 36.1 ft – 68.9 ft
 SFSL_3 + SFSL_4: 496,100 lb + 110,200 lb

* Main boom angle 85°
 Main boom angle 87°, 85°, 75°, 65° and 55°, capacities for intermediate boom positions are calculated by the crane control system IC-1

Operation

SWSL, SFSL

363,800 lb + 110,200 lb 36.1-68.9 ft										27.6 ft 32.2 ft/s 360° ASME B30.5									
315.0 ft + 196.9 ft					SWSL_1					SFSL_1	SFSL_3	SFSL_4	315.0 ft + 236.2 ft						
0 lb					0 lb - 716,600 lb					0 lb					0 lb - 716,600 lb				
87°/85° 87°/85° 75° 65° 55°					15° 15° 15°					87°/85° 87°/85° 75° 65° 55°					15° 15° 15°				
ft										1,000 lb									
72.2	137.8	141.1	-	-	-	-	-	-	-	82.0	105.8	108.9	-	-	-	-	-	-	-
78.7	136.7	140.0	-	-	-	-	-	-	-	85.3	105.4	108.2	-	-	-	-	-	-	-
85.3	133.4	137.8	-	-	-	-	-	-	-	91.9	104.3	106.9	-	-	-	-	-	-	-
91.9	129.0	140.0*	-	-	-	-	-	-	-	98.4	103.4	105.4	-	-	-	-	-	-	-
98.4	120.2	137.8*	-	-	-	-	-	-	-	111.5	95.9	105.8*	-	-	-	-	-	-	-
108.3	109.2	135.3*	-	-	-	-	134.5	192.9	201.7	121.4	87.1	103.8*	-	-	-	103.0	147.7	154.3	-
111.5	105.6	134.5*	-	-	-	-	134.1	192.9	201.7	124.7	84.2	103.2*	-	-	-	102.7	147.5	154.1	-
124.7	93.5	129.0*	-	-	-	-	133.0	192.9	201.7	137.8	74.5	100.3*	-	-	-	101.9	146.6	153.2	-
137.8	83.3	124.6*	-	-	-	-	132.3	192.9	201.7	150.9	66.1	97.0*	-	-	-	100.8	146.6	152.5	-
150.9	74.5	120.2*	-	-	-	-	129.3	190.7	199.5	164.0	58.9	93.7*	-	-	-	99.4	145.5	151.4	-
164.0	67.0	114.6*	-	-	-	-	126.8	188.5	196.9	177.2	52.7	90.2*	-	-	-	97.7	143.3	149.9	-
177.2	60.4	110.0*	122.4	-	-	-	124.6	186.3	194.0	190.3	47.2	86.6*	-	-	-	95.7	141.8	147.7	-
190.3	54.9	105.2*	121.3	-	-	-	121.6	183.4	191.1	193.6	46.0	85.8*	92.4	-	-	95.2	141.5	147.2	-
203.4	49.8	100.8*	119.0	-	-	-	118.3	180.4	187.8	203.4	42.3	83.3*	92.2	-	-	93.6	140.0	145.3	-
213.3	46.5	97.9*	116.6	-	-	-	115.6	178.2	185.0	216.5	37.9	79.8*	91.1	-	-	91.3	137.8	142.2	-
216.5	38.1*	97.0*	115.7	-	-	-	114.6	177.5	184.1	229.7	34.0	76.7*	89.5	-	-	88.8	135.6	140.0	-
223.1	36.4*	95.2*	113.5	-	-	-	113.0	174.8	181.1	242.8	30.6	73.9*	87.5	-	-	86.1	131.9	137.1	-
229.7	-	111.3	-	-	-	-	111.4	171.7	178.2	252.6	28.2	71.7*	85.7	-	-	84.0	129.7	134.3	-
242.8	-	107.6	-	-	-	-	107.8	165.3	170.9	255.9	21.2*	71.0*	85.1	-	-	83.3	129.0	133.4	-
255.9	-	103.0	-	-	-	-	103.8	158.7	162.0	262.5	19.8*	69.9*	83.8	-	-	81.7	127.1	131.2	-
259.2	-	101.7	99.2	-	-	-	102.8	156.5	159.1	269.0	-	-	82.5	-	-	80.2	125.3	129.0	-
269.0	-	97.9	98.8	-	-	-	99.9	149.9	150.3	282.2	-	-	79.1	72.8	-	77.2	122.4	124.6	-
278.9	-	93.9	97.1	-	-	-	96.9	142.2	141.1	295.3	-	-	76.1	72.8	-	74.3	117.9	120.2	-
282.2	-	-	96.6	-	-	-	95.9	138.9	138.0	308.4	-	-	72.5	72.1	-	71.2	112.1	112.1	-
295.3	-	-	93.3	-	-	-	91.9	127.9	125.7	318.2	-	-	69.7	70.6	-	68.9	106.8	105.6	-
308.4	-	-	89.1	-	-	-	87.8	116.1	114.1	321.5	-	-	-	70.1	-	68.1	104.4	103.2	-
321.5	-	-	84.7	-	-	-	83.0	105.7	103.5	334.6	-	-	-	67.9	-	65.0	95.0	93.5	-
331.4	-	-	80.7	-	-	-	79.6	98.8	96.3	347.8	-	-	-	64.8	-	61.7	86.2	84.5	-
334.6	-	-	-	-	-	-	78.3	96.6	93.9	360.9	-	-	-	61.7	-	58.2	78.3	76.1	-
337.9	-	-	-	-	-	75.0	77.1	94.4	91.7	364.2	-	-	-	60.8	54.0	57.3	76.4	74.2	-
347.8	-	-	-	-	-	73.4	73.6	88.0	85.2	367.5	-	-	-	60.0	54.0	56.4	74.5	72.3	-
360.9	-	-	-	-	-	70.1	68.9	79.7	76.9	374.0	-	-	-	-	53.8	54.7	70.8	68.6	-
374.0	-	-	-	-	-	66.4	64.2	71.7	68.8	387.1	-	-	-	-	52.0	50.6	63.8	61.5	-
377.3	-	-	-	-	-	65.3	62.9	69.8	66.9	400.3	-	-	-	-	49.8	47.0	57.1	54.6	-
387.1	-	-	-	-	-	-	59.0	64.3	61.4	413.4	-	-	-	-	47.0	43.4	50.5	47.8	-
400.3	-	-	-	-	-	-	53.4	57.2	54.2	416.7	-	-	-	-	46.1	42.5	48.7	46.3	-
413.4	-	-	-	-	-	-	47.6	50.3	47.4	426.5	-	-	-	-	-	39.6	44.2	41.7	-
426.5	-	-	-	-	-	-	40.6	43.9	41.1	439.6	-	-	-	-	-	35.6	38.3	35.6	-
439.6	-	-	-	-	-	-	33.0	37.3	34.8	452.8	-	-	-	-	-	31.5	32.6	30.0	-
452.8	-	-	-	-	-	-	24.9	29.8	27.8	465.9	-	-	-	-	-	24.9	27.3	24.7	-
465.9	-	-	-	-	-	-	19.1	20.8	18.8	479.0	-	-	-	-	-	18.1	22.2	19.4	-
469.2	-	-	-	-	-	-	18.1	18.5	16.5	492.1	-	-	-	-	-	11.5	16.1	14.3	-
										498.7	-	-	-	-	-	9.7	12.1	10.4	-
										502.0	-	-	-	-	-	-	10.1	-	-

0 lb 143,300 lb 275,600 lb 363,800 lb 452,000 lb 540,200 lb 628,400 lb 716,600 lb

SWSL_1: 36.1 ft – 62.3 ft

SWSL_3/SFSL_3, SWSL_4/SFSL_4: 36.1 ft – 68.9 ft

SFSL_3 + SFSL_4: 496,100 lb + 110,200 lb

* Main boom angle 85°

Main boom angle 87°, 85°, 75°, 65° and 55°, capacities for intermediate boom positions are calculated by the crane control system IC-1

Operation

SWSL, SFSL

363,800 lb + 110,200 lb 36.1-68.9 ft 27.6 ft 32.2 ft/s 360° ASME B30.5									
315.0 ft + 275.6 ft					315.0 ft + 315.0 ft				
SWSL_1					SFSL_1	SFSL_3	SFSL_4		
0 lb					0 lb - 716,600 lb				
87°/85° 87°/85° 75° 65° 55°					15° 15° 15°				
ft	1,000 lb								
91.9	79.1	81.8	-	-	-	-	-	-	-
98.4	78.5	80.9	-	-	-	-	-	-	-
111.5	77.2	80.2*	-	-	-	-	-	-	-
124.7	74.3	78.9*	-	-	-	-	-	-	-
134.5	67.8	77.8*	-	-	-	76.9	111.3	115.7	-
137.8	65.7	77.4*	-	-	-	76.7	110.2	114.6	-
150.9	57.8	75.4*	-	-	-	76.1	110.2	114.6	-
164.0	50.9	73.2*	-	-	-	75.3	109.9	114.3	-
177.2	44.8	71.0*	-	-	-	74.1	109.3	113.5	-
190.3	39.5	68.6*	-	-	-	72.6	107.7	111.3	-
203.4	34.6	66.1*	-	-	-	71.1	106.1	109.5	-
210.0	32.5	64.9*	66.6	-	-	70.4	105.3	108.8	-
216.5	30.4	63.7*	66.6	-	-	69.7	104.5	108.0	-
229.7	26.7	61.3*	66.6	-	-	67.8	102.6	106.0	-
242.8	23.1	58.9*	66.4	-	-	65.8	100.6	103.8	-
255.9	20.1	56.7*	65.3	-	-	63.9	98.5	101.6	-
269.0	17.2	54.5*	63.9	-	-	61.8	96.6	99.3	-
282.2	14.8	52.2*	62.4	-	-	59.5	94.1	97.1	-
288.7	13.7	51.4*	61.6	-	-	58.4	93.1	95.9	-
295.3	-	50.5*	60.8	-	-	57.3	92.2	94.8	-
301.8	-	49.4*	59.7	-	-	56.2	91.1	93.6	-
305.1	-	-	59.2	50.7	-	55.7	90.6	93.0	-
308.4	-	-	58.6	50.7	-	55.1	90.1	92.4	-
321.5	-	-	56.7	50.7	-	52.7	88.0	90.1	-
334.6	-	-	54.2	50.7	-	50.5	86.0	87.7	-
347.8	-	-	51.8	50.3	-	48.3	81.7	81.1	-
354.3	-	-	50.7	49.6	-	47.2	79.1	77.8	-
360.9	-	-	-	48.9	-	45.9	75.5	73.9	-
374.0	-	-	-	47.4	-	43.4	68.1	66.4	-
387.1	-	-	-	45.2	-	40.6	61.5	59.6	-
393.7	-	-	-	44.1	35.7	39.2	58.2	56.2	-
400.3	-	-	-	43.0	35.7	37.9	55.1	53.1	-
406.8	-	-	-	41.7	35.6	36.6	52.0	50.0	-
413.4	-	-	-	-	35.5	35.3	48.9	47.0	-
426.5	-	-	-	-	34.4	32.4	43.2	41.1	-
439.6	-	-	-	-	32.6	29.0	37.5	35.2	-
452.8	-	-	-	-	30.6	26.2	32.0	29.8	-
465.9	-	-	-	-	-	19.0	26.8	24.5	-
479.0	-	-	-	-	-	14.8	21.8	19.5	-
492.1	-	-	-	-	-	10.8	17.0	14.6	-
498.7	-	-	-	-	-	9.0	14.8	12.3	-
508.5	-	-	-	-	-	-	11.5	8.8	-
515.1	-	-	-	-	-	-	-	9.3	-

27.6 ft 32.2 ft/s 360° ASME B30.5									
315.0 ft + 315.0 ft					315.0 ft + 315.0 ft				
SWSL_1					SFSL_1	SFSL_3	SFSL_4		
0 lb					0 lb - 716,600 lb				
87°/85° 87°/85° 75° 65° 55°					15° 15° 15°				
ft	1,000 lb								
98.4	57.1	59.5	-	-	-	-	-	-	-
111.5	56.2	58.2	-	-	-	-	-	-	-
124.7	55.3	57.5*	-	-	-	-	-	-	-
137.8	53.8	56.7*	-	-	-	-	-	-	-
147.6	50.5	55.7*	-	-	-	-	-	-	83.6
150.9	49.6	55.3*	-	-	-	55.0	-	-	83.4
154.2	48.0	55.0*	-	-	-	54.8	80.3	-	83.3
164.0	43.0	54.0*	-	-	-	54.3	80.2	-	82.7
177.2	37.3	52.5*	-	-	-	53.6	79.8	-	82.0
190.3	32.2	51.1*	-	-	-	52.7	78.9	-	81.0
203.4	27.6	49.4*	-	-	-	51.4	77.7	-	79.9
216.5	23.4	47.8*	-	-	-	50.0	76.3	-	78.7
226.4	20.6	46.5*	45.2	-	-	49.2	75.2	-	77.7
229.7	19.6	46.1*	45.2	-	-	48.9	74.9	-	77.4
242.8	16.3	44.3*	45.2	-	-	47.5	73.4	-	75.8
255.9	13.2	42.5*	45.2	-	-	45.9	71.7	-	74.1
269.0	10.6	40.8*	45.2	-	-	44.4	70.1	-	72.3
275.6	9.3	39.9*	45.0	-	-	43.7	69.2	-	71.4
282.2	-	39.0*	44.8	-	-	42.8	68.4	-	70.5
295.3	-	37.5*	43.9	-	-	41.2	66.8	-	68.8
308.4	-	35.9*	42.8	-	-	39.5	65.2	-	67.0
321.5	-	34.4*	41.7	-	-	37.7	63.6	-	65.3
328.1	-	33.6*	41.0	31.7	-	36.8	62.8	-	64.4
334.6	-	32.8*	40.3	31.7	-	35.9	61.9	-	63.5
337.9	-	32.6*	40.0	31.7	-	35.5	61.5	-	63.1
347.8	-	-	38.8	31.7	-	34.3	60.3	-	61.7
360.9	-	-	37.5	31.7	-	32.6	58.8	-	58.1
374.0	-	-	35.9	31.7	-	30.9	57.3	-	55.6
387.1	-	-	34.4	31.5	-	29.1	55.4	-	53.4
393.7	-	-	33.5	31.4	-	28.2	54.5	-	52.2
400.3	-	-	-	31.3	-	27.2	51.6	-	49.8
413.4	-	-	-	30.0	-	25.1	45.9	-	44.1
423.2	-	-	-	29.0	20.1	23.6	41.8	-	39.9
426.5	-	-	-	28.7	20.1	23.0	40.4	-	38.5
439.6	-	-	-	26.9	19.8	20.8	35.1	-	33.1
442.9	-	-	-	26.5	19.8	20.3	33.7	-	31.8
452.8	-	-	-	-	19.6	18.7	30.0	-	28.0
465.9	-	-	-	-	19.2	16.6	25.1	-	23.1
479.0	-	-	-	-	17.9	14.0	20.3	-	18.2
492.1	-	-	-	-	16.3	11.7	15.7	-	13.4
502.0	-	-	-	-	-	9.5	12.3	-	10.1
505.3	-	-	-	-	-	-	11.2	-	9.0
511.8	-	-	-	-	-	-	9.0	-	-

0 lb 143,300 lb 275,600 lb 363,800 lb 452,000 lb 540,200 lb 628,400 lb 716,600 lb

SWSL_1: 36.1 ft – 62.3 ft

SWSL_3/SFSL_3, SWSL_4/SFSL_4: 36.1 ft – 68.9 ft

SFSL_3 + SFSL_4: 496,100 lb + 110,200 lb

* Main boom angle 85°

Main boom angle 87°, 85°, 75°, 65° and 55°, capacities for intermediate boom positions are calculated by the crane control system IC-1

Operation

SWSL, SFSL

363,800 lb + 110,200 lb 36.1-68.9 ft 27.6 ft 32.2 ft/s 360° ASME B30.5										
334.6 ft + 118.1 ft					334.6 ft + 157.5 ft					
SWSL_1					SFSL_1	SFSL_3	SFSL_4			
0 lb		0 lb - 716,600 lb								
87°/85°		87°/85°		75°	65°	55°	15°		15°	
ft	1,000 lb									
55.8	207.2	215.0	-	-	-	-	-	-	-	
59.1	207.2	212.7	-	-	-	-	-	-	-	
65.6	196.2	208.3	-	-	-	-	-	-	-	
72.2	180.8	213.8	-	-	-	-	-	-	-	
78.7	167.6	209.4*	-	-	-	-	-	-	-	
82.0	162.0	207.2*	-	-	-	205.0	-	-	-	
85.3	156.5	205.0*	-	-	-	203.9	-	-	-	
88.6	151.6	202.3*	-	-	-	203.4	291.0	308.6	-	
91.9	146.6	199.5*	-	-	-	202.8	291.0	308.6	-	
98.4	136.7	195.1*	-	-	-	201.7	291.0	308.6	-	
111.5	121.3	184.1*	-	-	-	198.8	286.6	306.4	-	
124.7	108.9	174.2*	-	-	-	195.1	284.4	302.0	-	
137.8	98.8	165.3*	-	-	-	190.7	284.4	302.0	-	
150.9	79.4*	158.7*	187.4	-	-	185.6	277.8	293.2	-	
164.0	-	-	180.8	-	-	180.0	271.9	285.1	-	
177.2	-	-	172.0	-	-	174.2	264.6	273.4	-	
190.3	-	-	163.1	-	-	168.4	249.9	254.3	-	
203.4	-	-	153.2	-	-	161.7	233.7	233.7	-	
206.7	-	-	151.0	-	-	159.8	229.3	229.0	-	
216.5	-	-	-	-	-	154.3	216.1	215.0	-	
226.4	-	-	-	143.3	-	148.8	202.8	201.2	-	
229.7	-	-	-	142.2	-	147.0	198.4	196.6	-	
242.8	-	-	-	134.5	-	139.8	181.1	178.9	-	
255.9	-	-	-	125.7	-	132.3	164.2	162.0	-	
262.5	-	-	-	120.2	-	128.6	156.3	153.8	-	
269.0	-	-	-	-	-	124.9	148.4	145.5	-	
282.2	-	-	-	-	-	117.6	134.8	131.9	-	
292.0	-	-	-	-	106.9	112.1	125.5	123.1	-	
295.3	-	-	-	-	105.4	110.2	122.4	120.2	-	
308.4	-	-	-	-	98.3	100.8	111.6	108.7	-	
315.0	-	-	-	-	94.6	96.1	106.3	103.0	-	
321.5	-	-	-	-	-	91.6	101.1	97.8	-	
334.6	-	-	-	-	-	82.7	90.8	87.5	-	
347.8	-	-	-	-	-	74.7	81.4	78.1	-	
360.9	-	-	-	-	-	67.2	72.4	69.2	-	
374.0	-	-	-	-	-	60.2	64.2	60.6	-	
387.1	-	-	-	-	-	50.3	55.5	53.1	-	
400.3	-	-	-	-	-	40.4	45.5	43.4	-	
410.1	-	-	-	-	-	33.7	37.3	35.1	-	

334.6 ft + 157.5 ft										
SWSL_1					SFSL_1	SFSL_3	SFSL_4			
0 lb		0 lb - 716,600 lb								
87°/85°		87°/85°		75°	65°	55°	15°		15°	
ft	1,000 lb									
65.6	163.1	166.4	-	-	-	-	-	-	-	
72.2	159.8	164.2	-	-	-	-	-	-	-	
78.7	154.3	160.9	-	-	-	-	-	-	-	
85.3	143.3	164.2*	-	-	-	-	-	-	-	
91.9	133.4	162.0*	-	-	-	-	-	-	-	
95.1	129.0	160.4*	-	-	-	155.4	-	-	-	
98.4	124.6	158.7*	-	-	-	155.4	-	-	-	
101.7	121.0	157.1*	-	-	-	155.1	224.9	238.1	-	
111.5	110.2	152.1*	-	-	-	154.0	227.1	240.3	-	
124.7	98.1	145.5*	-	-	-	151.8	226.3	238.1	-	
137.8	88.0	138.9*	-	-	-	148.8	224.9	238.1	-	
150.9	79.1	132.3*	-	-	-	145.9	222.7	234.4	-	
164.0	71.9	125.7*	-	-	-	142.6	220.1	232.2	-	
167.3	70.3	124.3*	141.1	-	-	141.6	219.9	231.5	-	
177.2	65.7	120.2*	138.9	-	-	138.9	219.4	229.3	-	
187.0	52.7*	117.9*	135.6	-	-	135.6	216.6	224.9	-	
190.3	-	-	134.5	-	-	134.5	215.7	224.1	-	
203.4	-	-	127.9	-	-	129.7	211.1	219.7	-	
216.5	-	-	122.4	-	-	124.6	203.9	207.2	-	
229.7	-	-	115.7	-	-	119.4	190.7	191.8	-	
242.8	-	-	109.8	-	-	114.2	177.1	176.7	-	
246.1	-	-	108.2	111.3	-	112.9	173.6	173.1	-	
255.9	-	-	-	109.1	-	108.9	163.1	162.0	-	
269.0	-	-	-	104.5	-	103.6	149.9	147.7	-	
282.2	-	-	-	98.8	-	98.3	136.7	134.5	-	
295.3	-	-	-	92.8	-	92.8	123.5	121.3	-	
301.8	-	-	-	89.5	-	90.2	118.1	115.7	-	
308.4	-	-	-	-	-	87.5	112.7	110.1	-	
321.5	-	-	-	-	80.5	81.5	102.4	99.4	-	
334.6	-	-	-	-	76.1	75.8	92.6	89.7	-	
347.8	-	-	-	-	71.2	70.3	83.6	80.6	-	
351.1	-	-	-	-	70.1	68.9	81.4	78.3	-	
360.9	-	-	-	-	-	64.7	74.8	71.9	-	
374.0	-	-	-	-	-	59.1	66.6	63.5	-	
387.1	-	-	-	-	-	53.2	58.9	55.9	-	
400.3	-	-	-	-	-	47.0	51.6	48.6	-	
413.4	-	-	-	-	-	40.6	44.8	41.7	-	
426.5	-	-	-	-	-	32.0	37.1	35.3	-	
439.6	-	-	-	-	-	23.5	28.4	26.2	-	
449.5	-	-	-	-	-	19.6	21.2	19.0	-	

0 lb 143,300 lb 275,600 lb 363,800 lb 452,000 lb 540,200 lb 628,400 lb 716,600 lb

SWSL_1: 36.1 ft – 62.3 ft

SWSL_3/SFSL_3, SWSL_4/SFSL_4: 36.1 ft – 68.9 ft

SFSL_3 + SFSL_4: 496,100 lb + 110,200 lb

* Main boom angle 85°

Main boom angle 87°, 85°, 75°, 65° and 55°, capacities for intermediate boom positions are calculated by the crane control system IC-1

Operation

SWSL, SFSL

363,800 lb + 110,200 lb 36.1-68.9 ft										27.6 ft 32.2 ft/s 360° ASME B30.5										
334.6 ft + 196.9 ft										334.6 ft + 236.2 ft										
SWSL_1					SFSL_1	SFSL_3	SFSL_4						SWSL_1					SFSL_1	SFSL_3	SFSL_4
0 lb					0 lb - 716,600 lb					0 lb					0 lb - 716,600 lb					
87°/85° 87°/85° 75° 65° 55°					15° 15° 15°					87°/85° 87°/85° 75° 65° 55°					15° 15° 15°					
ft										1,000 lb										
75.5	124.6	127.9	-	-	-	-	-	-	-	82.0	95.5	98.3	-	-	-	-	-	-	-	
78.7	123.5	126.8	-	-	-	-	-	-	-	85.3	94.8	97.9	-	-	-	-	-	-	-	
85.3	121.3	124.6	-	-	-	-	-	-	-	91.9	93.9	96.6	-	-	-	-	-	-	-	
91.9	119.0	126.8*	-	-	-	-	-	-	-	98.4	92.8	95.2	-	-	-	-	-	-	-	
98.4	114.6	124.6*	-	-	-	-	-	-	-	111.5	89.3	95.0*	-	-	-	-	-	-	-	
108.3	104.1	122.1*	-	-	-	-	120.2	176.4	185.2	121.4	82.1	93.2*	-	-	-	92.2	135.6	141.1	-	
111.5	100.5	121.3*	-	-	-	-	119.8	176.4	184.8	124.7	79.8	92.6*	-	-	-	91.9	135.4	141.1	-	
124.7	88.8	116.8*	-	-	-	-	118.7	176.0	184.1	137.8	70.5	89.7*	-	-	-	91.1	134.5	141.1	-	
137.8	79.1	112.4*	-	-	-	-	117.9	175.3	184.1	150.9	62.6	86.6*	-	-	-	90.0	134.5	140.4	-	
150.9	70.8	107.8*	-	-	-	-	115.7	173.8	181.9	164.0	55.6	83.6*	-	-	-	88.6	133.7	139.3	-	
164.0	63.5	103.2*	-	-	-	-	113.2	172.0	179.7	177.2	49.6	80.2*	-	-	-	86.6	132.3	137.8	-	
177.2	57.3	98.5*	-	-	-	-	110.2	169.8	177.5	190.3	44.3	76.9*	-	-	-	84.5	130.1	135.6	-	
183.7	54.6	96.3*	108.5	-	-	-	110.0	168.7	176.0	200.1	40.7	74.5*	80.9	-	-	83.0	128.6	134.1	-	
190.3	51.8	94.1*	107.6	-	-	-	108.4	167.6	174.5	203.4	39.5	73.6*	80.9	-	-	82.4	128.2	133.7	-	
203.4	47.2	90.2*	105.6	-	-	-	105.1	164.8	171.6	216.5	35.3	70.5*	80.0	-	-	80.0	125.7	131.2	-	
213.3	43.9	87.5*	103.1	-	-	-	102.7	162.6	169.4	229.7	31.5	67.7*	78.5	-	-	77.5	123.5	129.0	-	
216.5	35.1*	86.6*	102.3	-	-	-	101.9	162.0	168.7	242.8	28.2	64.8*	76.5	-	-	75.0	121.3	126.4	-	
226.4	32.4*	84.2*	99.3	-	-	-	99.1	159.3	164.8	252.6	26.0	63.0*	74.4	-	-	73.0	119.6	124.2	-	
229.7	-	-	98.3	-	-	-	98.2	158.4	163.9	255.9	18.3*	62.4*	73.6	-	-	72.3	119.0	123.5	-	
242.8	-	-	94.1	-	-	-	94.4	152.5	158.4	262.5	17.2*	61.3*	72.3	-	-	70.9	117.3	121.3	-	
255.9	-	-	89.9	-	-	-	90.4	146.6	151.0	269.0	-	-	71.0	-	-	69.3	115.5	119.0	-	
269.0	-	-	85.5	84.2	-	-	86.2	140.4	141.1	282.2	-	-	68.1	-	-	66.2	111.8	114.6	-	
282.2	-	-	80.9	82.2	-	-	82.2	131.2	130.1	292.0	-	-	65.8	61.1	-	64.0	109.3	111.3	-	
295.3	-	-	-	79.1	-	-	78.0	120.2	119.0	295.3	-	-	65.0	61.1	-	63.3	108.5	110.2	-	
308.4	-	-	-	75.4	-	-	73.9	109.9	108.2	308.4	-	-	61.9	60.0	-	60.2	103.8	103.9	-	
321.5	-	-	-	71.2	-	-	69.9	99.5	97.3	321.5	-	-	58.6	58.6	-	57.0	97.1	96.3	-	
334.6	-	-	-	66.8	-	-	65.5	89.9	87.5	334.6	-	-	-	56.0	-	54.0	88.6	87.3	-	
337.9	-	-	-	65.7	-	-	64.4	87.9	85.4	347.8	-	-	-	53.1	-	50.8	80.0	78.2	-	
347.8	-	-	-	-	59.3	-	61.1	81.6	79.1	360.9	-	-	-	50.0	-	47.4	71.8	69.6	-	
360.9	-	-	-	-	56.7	-	56.7	73.4	71.0	374.0	-	-	-	47.0	40.8	43.7	64.6	62.4	-	
374.0	-	-	-	-	53.4	-	52.0	65.7	63.3	377.3	-	-	-	46.1	40.8	42.8	62.9	60.7	-	
387.1	-	-	-	-	49.6	-	47.5	58.5	55.9	387.1	-	-	-	-	39.7	40.3	57.8	55.5	-	
390.4	-	-	-	-	48.7	-	46.3	56.7	54.1	400.3	-	-	-	-	37.5	36.8	51.1	48.8	-	
400.3	-	-	-	-	-	-	43.0	51.4	48.9	413.4	-	-	-	-	35.1	33.3	44.8	42.3	-	
413.4	-	-	-	-	-	-	38.4	44.8	42.1	426.5	-	-	-	-	32.4	29.5	38.7	36.2	-	
426.5	-	-	-	-	-	-	33.7	38.6	35.7	439.6	-	-	-	-	-	25.6	32.8	30.4	-	
439.6	-	-	-	-	-	-	29.0	32.6	29.8	452.8	-	-	-	-	-	21.6	27.1	24.7	-	
452.8	-	-	-	-	-	-	24.3	26.9	24.0	465.9	-	-	-	-	-	17.8	21.8	19.4	-	
465.9	-	-	-	-	-	-	17.0	21.2	18.3	479.0	-	-	-	-	-	13.9	16.8	14.3	-	
479.0	-	-	-	-	-	-	11.1	12.9	11.1	492.1	-	-	-	-	-	9.9	11.9	9.5	-	
482.3	-	-	-	-	-	-	10.0	10.8	9.0	498.7	-	-	-	-	-	-	9.5	-	-	
485.6	-	-	-	-	-	-	8.8	-	-	-	-	-	-	-	-	-	-	-	-	

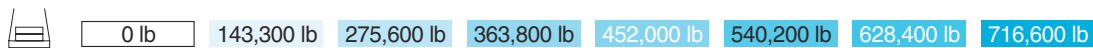

SWSL_1: 36.1 ft – 62.3 ft

SWSL_3/SFSL_3, SWSL_4/SFSL_4: 36.1 ft – 68.9 ft

SFSL_3 + SFSL_4: 496,100 lb + 110,200 lb

* Main boom angle 85°

Main boom angle 87°, 85°, 75°, 65° and 55°, capacities for intermediate boom positions are calculated by the crane control system IC-1

Operation

SWSL, SFSL

363,800 lb + 110,200 lb 36.1-68.9 ft 27.6 ft 32.2 ft/s 360° ASME B30.5									
334.6 ft + 275.6 ft					354.3 ft + 118.1 ft				
SWSL_1					SWSL_1				
0 lb					0 lb - 716,600 lb				
87°/85° 87°/85° 75° 65° 55°					15° 15° 15°				
ft	1,000 lb								
91.9	70.8	73.4	-	-	-	-	-	-	-
98.4	70.1	72.5	-	-	-	-	-	-	-
111.5	68.8	71.9*	-	-	-	-	-	-	-
124.7	66.8	70.5*	-	-	-	-	-	-	-
134.5	62.8	69.2*	-	-	-	68.3	102.1	106.9	-
137.8	61.7	68.8*	-	-	-	68.1	102.1	106.7	-
150.9	54.2	67.0*	-	-	-	67.4	101.6	106.3	-
164.0	47.4	64.8*	-	-	-	66.5	101.2	105.7	-
177.2	41.7	62.6*	-	-	-	65.5	100.8	104.9	-
190.3	36.6	60.2*	-	-	-	63.8	99.1	103.3	-
203.4	32.0	58.0*	-	-	-	62.3	97.6	101.6	-
216.5	28.0	55.8*	58.0	-	-	60.8	96.1	100.1	-
229.7	24.3	53.4*	58.0	-	-	59.1	94.5	98.2	-
242.8	20.9	50.9*	57.1	-	-	57.2	92.7	96.2	-
255.9	17.9	48.7*	56.0	-	-	55.1	90.8	94.1	-
269.0	15.2	46.7*	54.7	-	-	53.1	89.1	92.1	-
282.2	12.8	44.8*	52.9	-	-	50.9	86.7	89.8	-
292.0	10.4	43.4*	51.6	-	-	49.1	85.2	87.9	-
295.3	-	43.0*	51.1	-	-	48.5	84.7	87.3	-
301.8	-	42.3*	50.2	-	-	47.3	83.6	86.1	-
308.4	-	-	49.2	-	-	46.2	82.5	84.8	-
315.0	-	-	48.2	41.4	-	45.0	81.4	83.6	-
321.5	-	-	47.2	41.4	-	43.8	80.3	82.2	-
334.6	-	-	45.0	41.2	-	41.4	78.3	79.8	-
347.8	-	-	42.8	40.3	-	39.0	74.3	73.2	-
360.9	-	-	40.3	38.6	-	36.5	68.8	66.5	-
374.0	-	-	-	36.8	-	34.2	61.9	59.7	-
387.1	-	-	-	34.8	-	31.5	55.3	53.2	-
400.3	-	-	-	32.6	-	28.6	49.0	47.0	-
403.5	-	-	-	32.1	25.1	27.9	47.5	45.4	-
413.4	-	-	-	30.4	24.5	25.8	43.0	40.8	-
426.5	-	-	-	-	23.4	23.0	37.2	35.0	-
439.6	-	-	-	-	21.6	20.1	31.7	29.5	-
452.8	-	-	-	-	19.8	17.2	26.5	24.0	-
465.9	-	-	-	-	17.9	14.4	21.2	19.0	-
479.0	-	-	-	-	-	11.1	16.4	14.1	-
485.6	-	-	-	-	-	9.3	14.0	-	-
492.1	-	-	-	-	-	-	11.7	-	-
498.7	-	-	-	-	-	-	9.3	-	-

0 lb 143,300 lb 275,600 lb 363,800 lb 452,000 lb 540,200 lb 628,400 lb 716,600 lb									
SWSL_1: 36.1 ft – 62.3 ft					SWSL_3/SFSL_3, SWSL_4/SFSL_4: 36.1 ft – 68.9 ft				
SFSL_3 + SFSL_4: 496,100 lb + 110,200 lb									

* Main boom angle 85°
 Main boom angle 87°, 85°, 75°, 65° and 55°, capacities for intermediate boom positions are calculated by the crane control system IC-1

Operation

SWSL, SFSL

363,800 lb + 110,200 lb 36.1-68.9 ft 27.6 ft 32.2 ft/s 360° ASME B30.5										
354.3 ft + 157.5 ft					354.3 ft + 196.9 ft					
SWSL_1					SFSL_1	SFSL_3	SFSL_4			
0 lb					0 lb - 716,600 lb					
87°/85° 87°/85° 75° 65° 55°					15° 15° 15°					
ft	1,000 lb									
65.6	143.3	147.7	-	-	-	-	-	-	-	
72.2	142.2	145.5	-	-	-	-	-	-	-	
78.7	138.9	142.2	-	-	-	-	-	-	-	
85.3	134.5	145.5*	-	-	-	-	-	-	-	
91.9	126.8	142.2*	-	-	-	-	-	-	-	
98.4	119.0	140.0*	-	-	-	138.9	210.5	220.5	-	
111.5	105.2	134.5*	-	-	-	136.7	210.5	220.5	-	
124.7	93.3	127.9*	-	-	-	134.5	209.8	220.1	-	
137.8	83.6	122.4*	-	-	-	132.3	208.3	219.4	-	
150.9	75.4	115.7*	-	-	-	128.6	205.8	216.4	-	
164.0	68.1	110.2*	-	-	-	125.3	203.6	213.1	-	
170.6	65.1	108.0*	123.5	-	-	123.8	202.1	211.3	-	
177.2	62.2	105.8*	122.4	-	-	122.4	200.6	209.4	-	
190.3	47.4*	101.6*	117.9	-	-	117.2	194.7	203.6	-	
203.4	-	-	112.4	-	-	112.7	190.7	197.1	-	
216.5	-	-	107.4	-	-	108.7	186.3	191.8	-	
229.7	-	-	101.6	-	-	103.4	176.0	177.8	-	
242.8	-	-	95.7	-	-	98.1	164.6	164.2	-	
249.3	-	-	92.6	-	-	95.5	158.4	157.6	-	
255.9	-	-	-	92.2	-	92.8	152.1	151.0	-	
269.0	-	-	-	88.0	-	87.7	139.4	137.8	-	
282.2	-	-	-	82.9	-	82.5	127.5	124.9	-	
295.3	-	-	-	77.6	-	77.2	115.7	112.4	-	
308.4	-	-	-	72.1	-	71.9	104.4	101.1	-	
321.5	-	-	-	-	-	66.6	94.0	91.3	-	
331.4	-	-	-	-	61.3	62.6	87.2	84.3	-	
334.6	-	-	-	-	60.4	61.3	84.9	82.0	-	
347.8	-	-	-	-	56.2	56.1	76.2	73.3	-	
360.9	-	-	-	-	51.8	51.0	67.9	65.0	-	
364.2	-	-	-	-	50.7	49.8	65.9	63.1	-	
374.0	-	-	-	-	-	46.1	60.0	57.1	-	
387.1	-	-	-	-	-	40.5	52.5	49.6	-	
400.3	-	-	-	-	-	34.9	45.3	42.4	-	
413.4	-	-	-	-	-	29.8	38.6	35.7	-	
426.5	-	-	-	-	-	24.5	32.4	29.4	-	
439.6	-	-	-	-	-	19.6	25.9	23.4	-	
452.8	-	-	-	-	-	15.0	19.2	17.2	-	
462.6	-	-	-	-	-	11.7	12.6	10.6	-	
465.9	-	-	-	-	-	10.6	10.4	-	-	
75.5	111.3	114.6	-	-	-	-	-	-	-	
78.7	110.2	113.5	-	-	-	-	-	-	-	
85.3	109.3	111.3	-	-	-	-	-	-	-	
91.9	107.6	110.2	-	-	-	-	-	-	-	
98.4	105.2	111.3*	-	-	-	-	-	-	-	
111.5	95.2	108.2*	-	-	-	107.4	165.3	174.2	-	
124.7	84.2	104.5*	-	-	-	105.9	165.0	173.1	-	
137.8	75.0	100.1*	-	-	-	104.7	164.2	173.1	-	
150.9	67.0	95.9*	-	-	-	102.4	162.8	171.6	-	
164.0	60.0	91.5*	-	-	-	100.0	161.3	169.8	-	
177.2	54.0	87.3*	-	-	-	97.7	159.8	167.6	-	
187.0	50.0	84.3*	94.4	-	-	95.6	158.2	165.3	-	
190.3	48.7	83.3*	93.9	-	-	94.9	157.6	164.6	-	
203.4	44.1	79.8*	91.7	-	-	91.8	154.5	161.4	-	
216.5	40.3	76.5*	88.8	-	-	88.4	152.1	158.7	-	
226.4	29.1*	74.5*	85.9	-	-	85.9	149.9	155.4	-	
229.7	-	-	84.9	-	-	85.0	149.2	154.7	-	
242.8	-	-	81.1	-	-	81.2	144.0	149.9	-	
255.9	-	-	76.9	-	-	77.2	138.9	143.3	-	
269.0	-	-	72.8	-	-	72.9	131.7	131.4	-	
278.9	-	-	69.8	68.3	-	69.7	125.5	123.1	-	
282.2	-	-	68.8	67.9	-	68.7	123.1	120.5	-	
288.7	-	-	66.8	66.5	-	66.7	118.3	115.4	-	
295.3	-	-	-	65.0	-	64.6	113.5	110.2	-	
308.4	-	-	-	61.5	-	60.5	103.7	100.4	-	
321.5	-	-	-	57.8	-	56.3	93.9	90.8	-	
334.6	-	-	-	54.0	-	52.0	84.0	81.6	-	
347.8	-	-	-	50.0	-	47.8	75.7	73.0	-	
357.6	-	-	-	-	42.8	44.6	69.8	66.8	-	
360.9	-	-	-	-	42.1	43.6	68.0	64.8	-	
374.0	-	-	-	-	39.2	39.5	60.6	56.9	-	
387.1	-	-	-	-	36.2	35.3	53.4	49.8	-	
400.3	-	-	-	-	33.1	31.3	46.5	43.1	-	
413.4	-	-	-	-	-	27.1	39.9	36.6	-	
426.5	-	-	-	-	-	23.0	33.5	30.9	-	
439.6	-	-	-	-	-	19.0	27.5	14.7	-	
452.8	-	-	-	-	-	14.8	21.6	9.3	-	
465.9	-	-	-	-	-	10.7	16.0	-	-	
469.2	-	-	-	-	-	9.7	14.6	-	-	
479.0	-	-	-	-	-	-	10.6	-	-	
482.3	-	-	-	-	-	-	9.3	-	-	

0 lb 143,300 lb 275,600 lb 363,800 lb 452,000 lb 540,200 lb 628,400 lb 716,600 lb

SWSL_1: 36.1 ft – 62.3 ft

SWSL_3/SFSL_3, SWSL_4/SFSL_4: 36.1 ft – 68.9 ft

SFSL_3 + SFSL_4: 496,100 lb + 110,200 lb

* Main boom angle 85°

Main boom angle 87°, 85°, 75°, 65° and 55°, capacities for intermediate boom positions are calculated by the crane control system IC-1

Operation

SWSL, SFSL

496,100 lb + 110,200 lb 36.1-68.9 ft				27.6 ft 32.2 ft/s 360° ASME B30.5			
354.3 ft + 236.2 ft				354.3 ft + 275.6 ft			
SFSL_3 SFSL_4 0 lb 0 lb - 716,600 lb 15° 15° 15°				SFSL_3 SFSL_4 0 lb 0 lb - 716,600 lb 15° 15° 15°			
ft	1,000 lb			ft	1,000 lb		
124.7	92.8	126.8	133.4	137.8	68.1	96.3	101.2
137.8	75.8	126.8	133.4	150.9	56.2	96.0	100.8
150.9	59.8	126.8	132.6	164.0	44.3	95.7	100.3
164.0	45.4	126.0	131.5	177.2	32.4	95.2	99.9
177.2	32.6	124.6	130.1	190.3	21.8	93.9	98.3
190.3	21.9	123.1	128.6	203.4	11.8	92.5	96.6
203.4	11.8	121.3	126.8	206.7	9.5	92.1	96.2
206.7	9.5	120.7	126.2	216.5	-	91.1	95.0
216.5	-	119.0	124.6	229.7	-	89.6	93.4
229.7	-	116.8	122.4	242.8	-	88.0	91.6
242.8	-	114.6	119.9	255.9	-	86.2	89.7
255.9	-	112.4	116.8	269.0	-	84.4	87.8
269.0	-	109.3	113.5	282.2	-	82.2	85.4
282.2	-	105.5	109.1	295.3	-	79.8	82.9
295.3	-	101.6	104.7	308.4	-	77.3	79.9
308.4	-	96.9	97.8	321.5	-	74.8	77.0
321.5	-	90.5	89.9	334.6	-	72.3	74.1
334.6	-	82.5	81.4	347.8	-	69.4	69.0
347.8	-	74.2	72.9	360.9	-	62.8	61.9
360.9	-	66.3	64.6	374.0	-	56.2	54.9
374.0	-	58.6	56.7	387.1	-	49.5	48.0
387.1	-	51.8	49.8	400.3	-	43.1	41.4
400.3	-	45.6	43.4	413.4	-	37.3	35.5
413.4	-	39.2	37.0	426.5	-	31.8	29.9
426.5	-	33.4	31.2	439.6	-	26.5	24.4
439.6	-	27.7	25.4	452.8	-	21.2	19.2
452.8	-	22.3	19.8	465.9	-	16.2	14.0
465.9	-	17.0	14.7	479.0	-	11.4	9.0
479.0	-	11.9	9.5	485.6	-	9.0	-
485.6	-	9.5	-				

	0 lb	143,300 lb	275,600 lb	363,800 lb	452,000 lb	540,200 lb	628,400 lb	716,600 lb
--	------	------------	------------	------------	------------	------------	------------	------------

* Main boom angle 85°

Main boom angle 87°, 85°, 75°, 65° and 55°, capacities for intermediate boom positions are calculated by the crane control system IC-1

FIXED FLY JIB (VESSELLIFT)



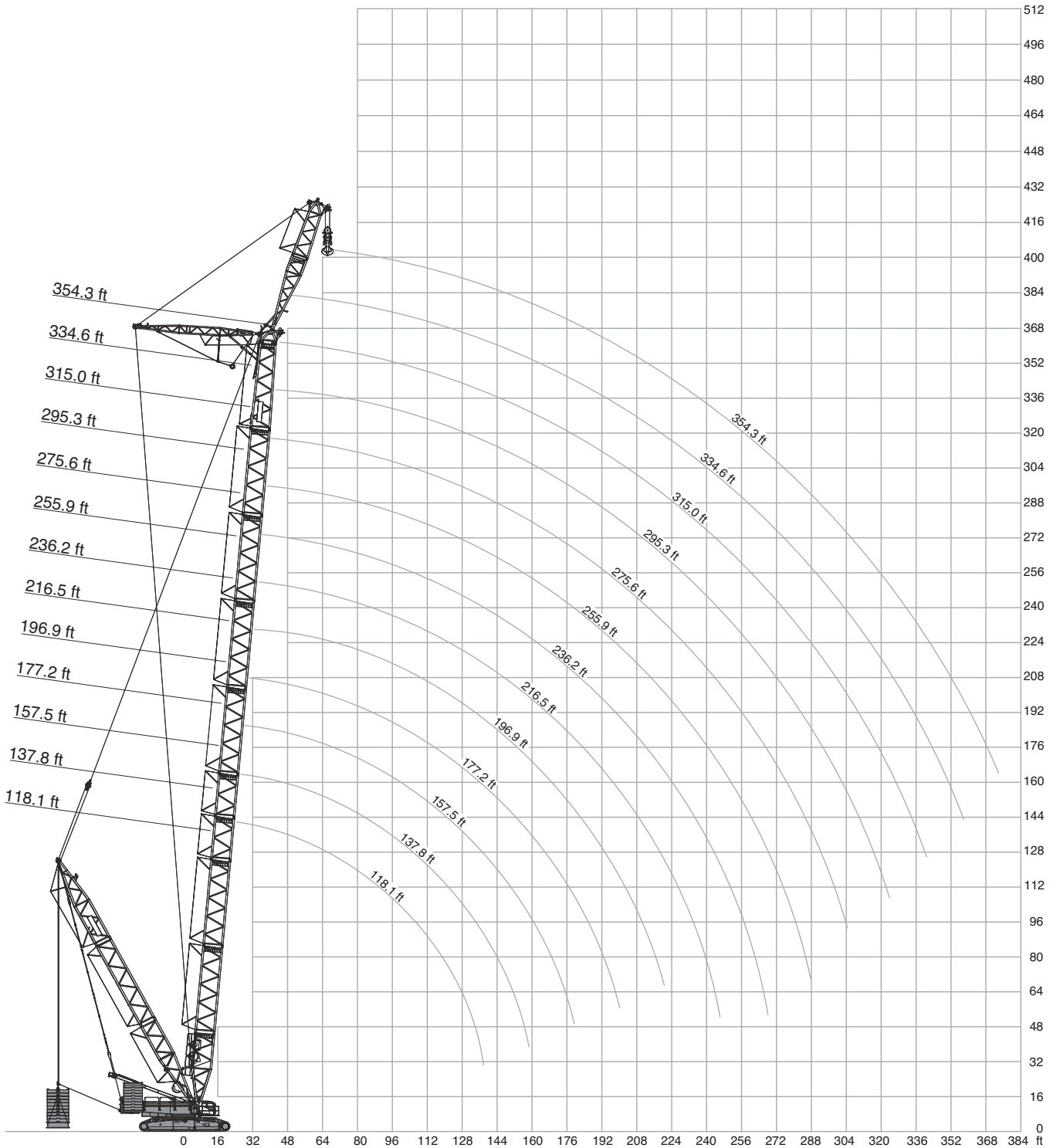

Operation

LVSL

363,800 lb + 110,200 lb 36.1-68.9 ft 59 ft 15° 27.6 ft 32.2 ft/s 360° ASME B30.5														
118.1 ft 137.8 ft 157.5 ft 177.2 ft 196.9 ft LVSL_1 LVSL_3 LVSL_1 LVSL_3 LVSL_1 LVSL_3 LVSL_4														
0 lb 0 lb-716.6klb 0 lb 0 lb-716.6klb 0 lb 0 lb-716.6klb 0 lb 0 lb-716.6klb 0 lb 0 lb-716.6klb														
ft	1,000 lb													
45.9	-	-	438.7	765.0	418.9	765.0	765.0	-	-	-	-	-	-	-
49.2	-	-	405.7	765.0	388.0	765.0	765.0	372.6	765.0	765.0	357.1	736.3	765.0	765.0
52.5	-	-	377.0	765.0	361.6	765.0	765.0	346.1	765.0	765.0	332.9	736.3	765.0	765.0
59.1	-	-	328.5	765.0	315.3	765.0	765.0	304.2	765.0	765.0	291.0	734.1	765.0	765.0
65.6	-	-	291.0	765.0	277.8	765.0	765.0	266.8	765.0	765.0	255.7	720.9	765.0	765.0
72.2	-	-	255.7	765.0	246.9	765.0	765.0	238.1	765.0	765.0	227.1	712.1	765.0	765.0
78.7	-	-	222.7	765.0	220.5	758.4	765.0	213.8	754.0	765.0	203.9	705.5	765.0	765.0
82.0	212.7	738.5	210.0	735.2	207.2	729.7	761.7	202.3	725.3	759.5	194.0	698.9	757.3	756.2
85.3	199.5	709.9	197.3	705.5	194.0	701.1	758.4	190.7	696.7	754.0	184.1	692.3	749.6	747.4
91.9	178.6	657.0	175.3	652.6	172.0	646.0	705.5	168.7	641.5	701.1	165.3	639.3	694.5	694.5
98.4	159.8	608.5	156.5	604.1	153.2	599.7	654.8	149.9	595.2	650.4	146.6	590.8	646.0	646.0
111.5	131.9	520.3	128.6	530.6	125.3	526.2	575.4	122.1	521.8	571.0	119.1	517.4	566.6	565.1
124.7	108.9	439.5	105.5	465.2	101.7	461.5	505.6	98.3	457.8	501.2	95.2	453.4	496.8	495.3
137.8	90.8	366.0	87.1	407.9	82.5	405.7	445.3	78.3	403.4	440.9	74.7	399.0	436.5	436.5
150.9	77.0	308.6	72.7	349.1	68.0	363.0	399.8	63.7	359.4	396.8	59.9	356.4	392.4	392.4
164.0	64.4	252.1	60.2	298.4	55.4	321.1	351.3	51.0	321.1	357.1	47.0	318.2	352.7	352.7
167.3	61.5	238.1	57.5	287.7	52.7	310.9	338.4	48.3	313.1	348.3	44.2	309.7	343.9	343.9
177.2	-	-	49.6	255.7	44.5	280.0	304.2	40.1	288.8	321.9	35.9	284.4	317.5	317.5
183.7	-	-	45.2	240.3	40.4	259.4	283.7	35.9	274.1	302.8	31.7	271.9	303.5	303.5
190.3	-	-	-	-	36.3	241.8	263.1	31.7	259.4	283.7	27.4	259.4	289.5	289.5
200.1	-	-	-	-	30.4	218.3	235.9	25.9	235.9	255.0	21.5	240.9	267.9	267.5
203.4	-	-	-	-	-	-	-	24.3	227.1	245.4	19.8	234.8	260.1	259.4
216.5	-	-	-	-	-	-	-	17.6	200.6	216.1	13.0	210.5	229.3	227.1
223.1	-	-	-	-	-	-	-	-	-	-	10.1	195.1	213.4	211.6
229.7	-	-	-	-	-	-	-	-	-	-	-	182.6	201.9	200.6
232.9	-	-	-	-	-	-	-	-	-	-	-	178.6	196.2	195.1

	0 lb	143,300 lb	275,600 lb	363,800 lb	452,000 lb	540,200 lb	628,400 lb	716,600 lb
--	------	------------	------------	------------	------------	------------	------------	------------

LVSL_1: 36.1 ft – 62.3 ft

LVSL_3, LVSL_4: 36.1 ft – 68.9 ft

LVSL_3 + LVSL_4: 496,100 lb + 110,200 lb

Operation

LVSL

363,800 lb + 110,200 lb 36.1-68.9 ft 59 ft 15° 27.6 ft 32.2 ft/s 360° ASME B30.5																
216.5 ft				236.2 ft				246.1 ft				255.9 ft				265.8 ft
LVSL_1		LVSL_3		LVSL_4		LVSL_1		LVSL_3		LVSL_4		LVSL_1		LVSL_3		LVSL_4
0 lb		0 lb -716.6 klb		0 lb		0 lb -716.6 klb		0 lb		0 lb -716.6 klb		0 lb		0 lb -716.6 klb		0 lb
ft																
1,000 lb																
52.5	319.7	648.2	765.0	765.0	306.4	577.6	692.3	692.3	-	-	-	-	-	-	-	-
55.8	299.8	648.2	765.0	765.0	286.6	577.6	692.3	692.3	681.2	692.3	275.6	478.4	650.4	679.0	617.3	619.5
59.1	280.0	648.2	765.0	765.0	269.0	577.6	692.3	692.3	681.2	692.3	257.9	478.4	650.4	676.8	615.1	619.5
65.6	246.9	648.2	765.0	765.0	235.9	577.6	692.3	692.3	674.6	692.3	229.3	478.4	648.2	676.8	612.9	619.5
72.2	220.5	639.3	765.0	765.0	210.5	577.6	692.3	692.3	668.0	687.8	202.8	476.2	641.5	672.4	610.7	619.5
78.7	197.3	632.7	758.4	765.0	187.4	571.0	692.3	692.3	661.4	683.4	180.8	471.8	637.1	665.8	606.3	619.5
85.3	176.4	626.1	745.2	743.0	168.7	564.4	692.3	692.3	657.0	676.8	162.0	467.4	632.7	659.2	601.9	619.5
91.9	158.7	619.5	692.3	690.0	151.0	560.0	687.8	683.4	652.6	672.4	145.5	463.0	623.9	648.2	595.2	617.3
98.4	143.3	588.6	641.5	641.5	136.7	553.4	639.3	634.9	632.7	628.3	131.2	458.6	615.1	626.1	586.4	610.7
111.5	116.8	515.1	562.2	560.7	112.6	500.4	558.5	555.6	551.9	549.0	108.2	443.9	547.5	549.7	533.5	538.7
124.7	93.3	451.2	493.1	491.6	90.2	447.5	488.7	486.5	482.8	479.9	87.3	420.3	485.0	482.8	477.7	474.0
137.8	72.5	396.8	434.3	434.3	69.4	394.6	429.9	427.7	425.5	421.1	68.3	392.4	427.7	425.5	418.9	416.7
150.9	57.7	354.2	388.7	388.7	54.5	352.0	384.3	382.1	379.9	377.0	53.2	349.8	382.1	379.9	374.8	372.6
164.0	44.7	316.0	349.1	349.1	41.3	313.8	344.7	342.5	340.2	338.0	40.0	312.3	341.7	339.5	335.8	333.6
177.2	33.5	282.2	315.3	315.3	30.0	280.0	310.9	308.6	306.4	304.2	28.7	280.0	306.4	304.2	302.0	299.8
190.3	24.8	257.2	287.3	287.3	21.2	253.5	282.9	280.7	278.5	276.3	19.7	253.5	280.0	277.8	274.1	271.9
203.4	17.0	234.4	262.4	261.6	13.1	230.4	257.9	255.7	253.5	251.3	11.5	228.5	255.7	252.8	249.1	246.5
206.7	15.3	229.3	256.8	255.7	11.3	225.4	252.4	250.2	248.0	245.8	9.7	222.7	250.2	246.9	243.6	240.7
210.0	13.6	224.1	251.3	249.9	9.5	220.5	246.9	244.7	242.5	240.3	-	218.3	244.7	241.0	238.1	235.0
216.5	10.1	213.8	240.3	238.1	-	210.5	235.9	233.7	231.5	229.3	-	209.4	233.7	229.3	227.1	224.9
229.7	-	194.0	213.8	212.4	-	193.6	217.5	213.8	212.7	210.5	-	192.5	213.8	211.6	208.7	206.5
242.8	-	170.9	188.1	186.3	-	176.4	196.6	193.3	194.4	191.8	-	176.7	196.9	194.7	191.8	189.6
252.6	-	155.4	172.0	170.9	-	163.1	178.9	175.6	180.0	176.9	-	165.7	184.8	182.6	180.2	178.0
255.9	-	-	-	-	-	158.7	173.1	169.8	175.3	172.0	-	162.0	180.8	178.6	176.4	174.2
269.0	-	-	-	-	-	137.8	155.4	151.0	152.9	149.9	-	146.6	159.5	156.5	158.0	155.8
278.9	-	-	-	-	-	-	-	-	141.1	137.8	-	133.7	143.3	140.0	143.9	141.5
282.2	-	-	-	-	-	-	-	-	-	-	-	128.6	140.0	136.3	138.9	136.5
285.4	-	-	-	-	-	-	-	-	-	-	-	123.5	136.7	133.4	133.9	131.4
295.3	-	-	-	-	-	-	-	-	-	-	-	-	-	-	124.6	121.3

	0 lb	143,300 lb	275,600 lb	363,800 lb	452,000 lb	540,200 lb	628,400 lb	716,600 lb
--	------	------------	------------	------------	------------	------------	------------	------------

LVSL_1: 36.1 ft – 62.3 ft

LVSL_3, LVSL_4: 36.1 ft – 68.9 ft

LVSL_3 + LVSL_4: 496,100 lb + 110,200 lb

Operation

LVSL

363,800 lb + 110,200 lb 36.1-68.9 ft 59 ft 15° 27.6 ft 32.2 ft/s 360° ASME B30.5																
275.6 ft				285.5 ft			295.3 ft				305.1 ft			315.0 ft		
LVSL_1		LVSL_3		LVSL_4		LVSL_3		LVSL_4		LVSL_1		LVSL_3		LVSL_4		
0 lb		0 lb - 716.6 klb				0 lb		0 lb - 716.6 klb				0 lb		0 lb - 716.6 klb		
ft																
55.8	264.6	432.1	599.7	619.5	-	-	-	-	-	-	-	-	-	-	-	-
59.1	246.9	432.1	599.7	619.5	568.8	595.2	238.1	385.8	540.1	544.5	509.3	537.9	227.1	346.1	491.6	520.3
65.6	219.4	429.9	597.5	619.5	566.6	593.0	209.4	385.8	537.9	544.5	509.3	533.5	199.5	346.1	491.6	518.1
72.2	194.0	427.7	595.2	619.5	562.2	590.8	185.2	381.4	533.5	544.5	507.1	531.3	176.4	343.9	491.6	513.7
78.7	173.1	423.3	588.6	615.1	555.6	584.2	165.3	379.2	531.3	544.5	502.7	526.9	156.5	341.7	485.0	513.7
85.3	154.3	418.9	584.2	608.5	551.2	579.8	146.6	374.8	526.9	544.5	496.0	524.7	138.9	337.3	482.8	507.1
91.9	137.8	414.5	577.6	604.1	549.0	575.4	131.2	370.4	520.3	544.5	496.0	520.3	123.5	332.9	480.6	502.7
98.4	123.5	410.1	571.0	597.5	544.5	568.8	116.8	366.0	515.9	542.3	491.6	513.7	110.2	328.5	474.0	498.2
111.5	101.3	396.8	531.3	537.2	513.7	521.8	95.1	355.7	496.8	510.7	474.0	491.6	88.6	318.2	459.3	482.1
124.7	81.7	381.4	482.1	478.4	471.8	469.6	76.0	343.9	466.6	470.3	449.0	457.1	69.7	307.2	441.7	454.9
137.8	64.8	368.2	423.3	421.1	414.5	412.3	59.5	330.7	421.1	418.9	407.9	405.7	53.4	295.4	412.3	412.3
150.9	50.0	340.2	379.2	377.0	370.4	368.2	46.6	316.0	377.0	374.8	365.2	363.0	40.7	282.2	371.1	369.6
164.0	36.8	309.4	339.5	337.3	331.4	329.2	34.4	296.9	337.3	335.1	327.0	324.1	29.4	269.7	332.9	330.7
177.2	25.4	275.6	304.2	302.0	297.6	295.4	22.9	273.4	302.0	299.8	293.2	288.8	19.4	257.9	297.6	295.4
190.3	16.4	250.6	276.3	274.1	269.7	267.5	13.8	248.4	272.6	270.4	265.3	262.4	9.9	244.7	269.7	267.5
196.9	11.9	238.1	262.4	260.1	255.7	253.5	9.3	235.9	257.9	255.7	251.3	249.1	-	231.5	255.7	253.5
200.1	9.9	231.5	256.8	254.6	250.2	248.0	-	230.6	252.6	250.2	244.7	243.6	-	226.3	249.1	246.9
203.4	-	226.4	251.3	249.1	244.7	242.5	-	225.2	247.4	244.7	239.4	238.1	-	221.2	242.5	241.6
216.5	-	206.1	229.3	227.1	222.7	220.5	-	203.9	224.9	224.9	218.3	216.1	-	200.6	222.7	220.5
229.7	-	189.2	209.4	208.0	204.3	202.1	-	187.0	206.5	205.8	199.9	197.7	-	183.7	203.6	201.4
242.8	-	173.4	192.5	190.3	187.0	185.2	-	171.2	189.6	188.1	182.6	180.8	-	167.9	185.9	183.7
255.9	-	158.7	176.4	174.2	170.9	169.8	-	156.5	174.2	172.0	166.4	165.3	-	153.2	169.8	167.6
269.0	-	147.0	162.4	159.5	157.6	155.8	-	144.2	160.2	157.3	153.2	151.0	-	140.4	155.8	153.4
282.2	-	135.6	145.5	142.2	143.3	140.9	-	132.3	147.3	143.3	140.4	138.2	-	129.0	142.6	139.6
295.3	-	117.9	125.7	122.4	125.7	122.4	-	121.3	132.3	129.0	127.9	125.7	-	117.9	130.1	125.7
301.8	-	109.1	119.0	114.6	116.7	113.5	-	114.1	123.7	120.5	119.9	117.6	-	112.8	123.4	119.6
308.4	-	-	-	-	111.4	106.4	-	107.0	115.1	112.1	112.0	109.5	-	107.7	116.7	113.5
311.7	-	-	-	-	108.9	104.1	-	103.4	110.8	107.8	108.0	105.5	-	105.1	113.4	110.4
321.5	-	-	-	-	-	-	-	91.7	99.2	95.0	96.1	93.4	-	95.4	102.2	99.6
328.1	-	-	-	-	-	-	-	-	-	-	91.3	86.4	-	88.3	94.4	91.8
334.6	-	-	-	-	-	-	-	-	-	-	-	-	-	81.1	86.6	84.0
337.9	-	-	-	-	-	-	-	-	-	-	-	-	-	77.6	83.1	80.0

0 lb
143,300 lb
275,600 lb
363,800 lb
452,000 lb
540,200 lb
628,400 lb
716,600 lb

LVSL_1: 36.1 ft – 62.3 ft

LVSL_3, LVSL_4: 36.1 ft – 68.9 ft

LVSL_3 + LVSL_4: 496,100 lb + 110,200 lb

Operation

LVSL

363,800 lb + 110,200 lb 36.1-68.9 ft 59 ft 15° 27.6 ft 32.2 ft/s 360° ASME B30.5													
324.8 ft		334.6 ft				344.5 ft			354.3 ft				
LVSL_3, LVSL_4		LVSL_1		LVSL_3, LVSL_4		LVSL_3, LVSL_4		LVSL_1		LVSL_3, LVSL_4			
0 lb - 716.6 klb		0 lb		0 lb - 716.6 klb				0 lb		0 lb - 716.6 klb			
ft	1,000 lb												ft
62.3	465.2	491.6	203.9	308.6	440.9	467.4	414.5	440.9	194.0	275.6	399.0	425.5	62.3
65.6	465.2	491.6	190.7	308.6	440.9	465.2	414.5	440.9	181.9	275.6	399.0	425.5	65.6
72.2	465.2	489.4	168.7	306.4	440.9	463.0	414.5	438.7	159.8	273.4	399.0	425.5	72.2
78.7	460.8	485.0	148.8	304.2	440.9	460.8	414.5	438.7	141.1	271.2	399.0	423.3	78.7
85.3	458.6	480.6	132.3	302.0	436.5	460.8	412.3	436.5	124.6	269.0	399.0	421.1	85.3
91.9	454.2	478.4	116.8	295.4	432.1	456.4	410.1	432.1	110.2	264.6	394.6	416.7	91.9
98.4	449.7	474.0	104.1	291.0	429.9	451.9	405.7	427.7	97.2	260.1	390.2	414.5	98.4
111.5	438.0	460.0	82.6	283.7	418.1	438.7	396.1	418.9	76.2	252.8	382.1	403.4	111.5
124.7	424.0	438.0	63.9	274.1	406.4	423.3	385.1	403.4	57.8	244.0	369.6	391.0	124.7
137.8	403.4	401.2	47.8	262.4	394.6	396.8	374.8	385.8	41.9	233.7	359.4	379.2	137.8
150.9	359.4	357.1	35.5	250.6	362.3	361.6	346.9	349.1	29.7	223.4	340.2	348.3	150.9
164.0	320.4	318.2	24.3	238.8	329.2	327.0	316.0	313.8	18.6	213.0	317.5	318.2	164.0
173.9	295.1	292.8	16.8	230.0	303.9	301.7	290.6	288.4	11.0	205.0	297.6	296.2	173.9
177.2	286.6	284.4	14.3	227.1	295.4	293.2	282.2	280.0	-	202.8	291.0	288.8	177.2
183.7	272.3	270.1	9.9	222.7	281.5	279.3	267.5	264.6	-	197.3	276.9	274.7	183.7
190.3	257.9	255.7	-	216.6	267.5	265.3	253.5	251.3	-	191.8	262.8	260.6	190.3
203.4	234.1	231.9	-	204.7	241.2	239.9	229.3	227.1	-	180.8	238.1	236.3	203.4
216.5	212.7	210.5	-	192.9	218.3	217.2	207.2	205.0	-	169.8	216.1	215.0	216.5
229.7	194.4	192.2	-	178.9	199.9	198.0	188.9	186.7	-	158.7	196.2	193.6	229.7
242.8	177.5	175.3	-	164.6	182.6	180.0	171.7	169.8	-	148.3	178.2	174.9	242.8
255.9	162.0	159.8	-	149.9	166.4	163.1	156.5	154.3	-	137.8	162.0	158.7	255.9
269.0	148.8	146.6	-	137.4	152.1	147.7	143.3	141.1	-	128.2	147.2	144.0	269.0
282.2	136.3	134.1	-	125.7	138.5	133.4	130.8	128.6	-	118.7	133.4	130.1	282.2
295.3	124.6	122.4	-	114.6	124.6	120.2	119.0	116.8	-	109.1	120.2	116.8	295.3
308.4	111.6	109.1	-	104.9	113.5	108.8	109.3	106.0	-	99.7	108.7	105.0	308.4
321.5	98.0	95.2	-	95.7	102.6	97.9	97.4	94.1	-	90.5	97.8	94.1	321.5
334.6	83.6	80.9	-	84.4	90.8	88.2	84.2	81.8	-	81.6	87.5	83.8	334.6
344.5	74.7	71.0	-	74.7	80.2	77.6	74.6	72.2	-	74.4	80.1	77.0	344.5
347.8	-	-	-	71.5	76.7	74.1	71.4	69.0	-	72.0	77.7	74.7	347.8
354.3	-	-	-	65.0	69.7	67.0	65.0	62.6	-	67.2	72.8	70.1	354.3
360.9	-	-	-	-	-	-	59.3	56.3	-	61.5	66.2	63.8	360.9
364.2	-	-	-	-	-	-	57.5	54.0	-	58.5	63.1	60.6	364.2
370.7	-	-	-	-	-	-	-	-	-	52.7	56.7	54.2	370.7

0 lb
143,300 lb
275,600 lb
363,800 lb
452,000 lb
540,200 lb
628,400 lb
716,600 lb

LVSL_1: 36.1 ft – 62.3 ft

LVSL_3, LVSL_4: 36.1 ft – 68.9 ft

LVSL_3 + LVSL_4: 496,100 lb + 110,200 lb

Notes to Lifting Capacity

Ratings are in compliance with EN 13000. They do not exceed 75% of tipping load, according to ASME B30.5.

Weight of hook blocks and slings is part of the load, and is to be deducted from the capacity ratings.
Consult operation manual for further details.

Note: Data published herein is intended as a guide only and shall not be construed to warrant applicability for lifting purposes.
Crane operation is subject to the computer charts and operation manual both supplied with the crane.

In some instances the superlift counterweight does not lift off the ground with the indicated load.

TECHNICAL DESCRIPTION

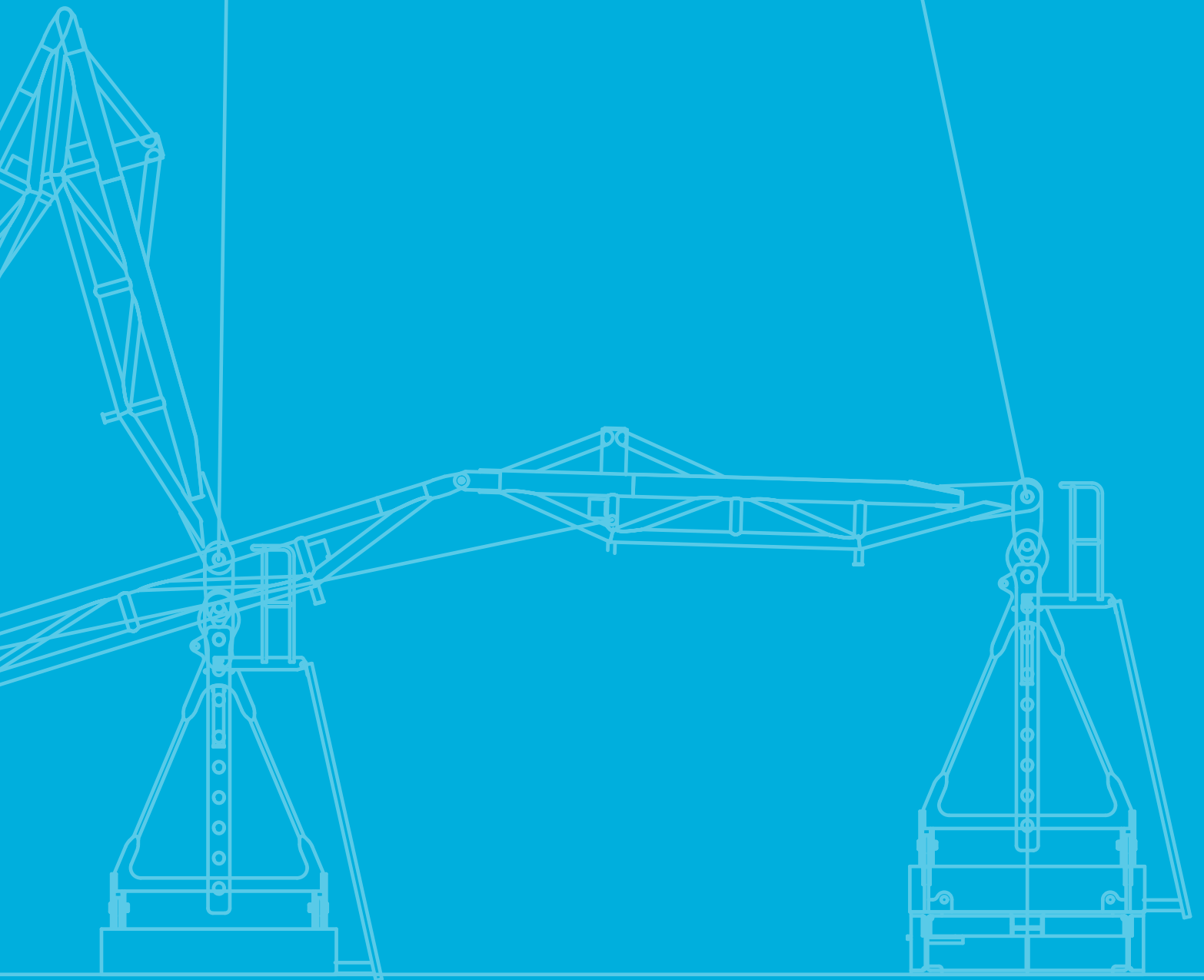

Technical Description

Crawler carrier	
3-section carrier comprising of carbody and two crawlers. Hydraulic pin connections between crawlers and carbody provide for easy assembly and removal to minimise width and weight for transportation. Track width: 27.6 ft.	
Carbody	Bending- and torsion-resistant welded structure of box type construction, fabricated of high-strength fine grain structural steel.
Crawlers	Bending-resistant welded structure of high-strength fine grain structural steel. Automatic centralised lubrication is included as standard. 16 rollers on each side frame with hardened rolling surfaces. Raised position for both drive sprockets and idler wheels, drive sprockets and idler wheels provide load bearing capacity for erection, adjustable track tension. Crawler pads: 4.9 ft wide.
Crawler drive	The tracks are powered by one hydraulic motor each through closed planetary gear reduction units running in oil bath, equipped with spring-applied hydraulically released holding brakes; the gear units are of very compact design to fit within the width of the crawlers. Each crawler is infinitely variable controlled, both independently and in opposite direction. Tractive effort: 315 kip per side.
Assembly jacks	Four hydraulic jacking cylinders on carbody (folding within 9.8 ft width) for easy assembly of crawlers.
Superstructure	
Counterweight	452,000 lb (max. 496,100 lb) counterweight on superstructure combination with 110,200 lb central ballast. Steelbox type. Weight of counterweight blocks: 22,050 lb.
Total weight	Approx. 860,000 lb, incl. 363,800 lb counterweight, 78.7 ft SH_1 boom and hook block.
Travel speed on crawlers	Max. 0.68 mph.
Reeving winch	Mounted on superstructure.
Frame	Torsion-resistant welded structure fabricated of high-strength fine grain structural steel.
Slew ring	Triple-row roller bearing slew ring with external ring gear for ease of service and maintenance. Central lubrication system.
Drive EU Stage V / EPA Tier 4f	Mercedes-Benz diesel engine, type OM471LA, 6 cylinder, 390 kW (523 HP) at 1600 1/min, torque 2600 Nm at 1300 1/min. The engine complies with emission standard EU Stage V / EPA Tier 4f. Pump distribution gearbox with six variable displacement axial piston pumps and additional gear pumps. Stainless steel exhaust system with particle filter, SCR catalyzer and spark arrestor certificate. Sound insulation covering. Fuel: 321 gallons, AdBlue: 22.5 gallons.
Rope drums	The standard superstructure equipment includes three rope drums – hoist 1, 2 and boom hoist. The drums are powered by hydraulic motors through closed planetary gear units running in oil bath. All rope drums have spring-applied, hydraulically released multi-disk brakes and non-wearing hydraulic braking for load lowering. Rope ends H 1, 2, 3 and W 1, 2 equipped with quick-connect rope end-fittings. All winches are removable to minimise weight for transportation.
A-frame	Hydraulic raising systems for A-frame as standard. A-frame, boom hoist and sheave sets for boom hoist can be dismantled as one single transport unit to minimise transport weight. Dismantling of hoist 1 and 2 possible without removing A-frame first.
Slew unit	Powered by hydraulic motors through 2 closed, planetary gear units running in oil bath. Spring-applied, hydraulically released holding brakes and non-wearing hydraulic braking. Slew speed infinitely variable 0-1 rpm.
Control system	IC-1: Electronic proportional valve pilot control integrated in stored-program control system incl. diagnostic system. Two monitors with colour displays, load moment indicator operated via a touch screen. Working speeds infinitely variable controlled by the lever position. Automatic power control for optimal utilisation of engine output; emergency control systems. Additional functions: <ul style="list-style-type: none"> • Infinitely variable position of Superlift counterweight with the optional adjustable Superlift system 36.1 ft - 62.3 ft • Infinitely variable position of main boom angle in SWSL configuration 55-87° (65-87° in SW configuration) • Working area limitation • Diagnosis and troubleshooting • User defined joystick mode The crane is controlled by joystick levers ergonomically positioned in the crane cab. Wireless rigging remote control. Wireless emergency remote control.
Cab	Comfortable cab with large windscreen and air condition. Shatterproof-glazing all around, roof window, self-contained hot air heater, full instrumentation and crane controls. Infinitely adjustable operator seat, emergency seat, multiple storage areas, 12-V power plug. The cab can be tilted back for improved operator view of boom point. A camera system is installed to monitor the rope drums. Front window can be opened. Dashboard can be adjusted for optimum ergonomics and view. Front wiper with resting position outside of window area for optimum view. For transportation, the cab swings hydraulically in front of the superstructure to minimise width.

Technical Description

Electrical equipment	24 V DC. system (2 x batteries 12 V, 200 Ah).
Operator aids	Load moment indicator integrated in IC-1 control (load moment, radius, angles, engine and hydraulic system monitoring), hoist limit switch, limit switches for boom movements, hydraulic boom backstop, position light, anemometer.

Boom combinations

See page 18-25.

Optional equipment

Engine ECE R96	Optional for non-regulated markets: Mercedes-Benz diesel engine, type OM471 LA, 6 cylinder, 390 kW (523 HP) at 1700 1/min, torque 2460 Nm at 1300 1/min. The engine complies with emission standard ECE R96 (similar to EU Stage III / EPA Tier 3). Stainless steel exhaust system with spark arrestor certificate. Fuel: 321 gallons.
Hydraulic quick connection	Allows for quick separation of superstructure from carrier (thus reducing transport weight).
Crawler pads	6.6 ft.
Quadro drive	2 drives for each crawler carrier 585 lbf tractive force – at reduced drive speed.
Alternative counterweights made of cast iron	Reduced overall height (see page 14).
Alternative counterweight segmentation 22,050 lb + 16,540 lb or 22,050 lb + 33,080 lb	For optimized transport in certain markets.
Hydraulic cylinder on A-frame	For self-assembly of crawler carrier.
Hydraulic cylinder with or without hydraulic unit	For boom pinning.
Additional lateral outrigger system	For erection of long boom systems.
Boom Booster Kit	Consists of 2 x 39.4 ft adapter sections and up to 7 x 39.4 ft inserts. Available in length 78.7 ft, 157.5 ft, 196.9 ft, 275.6 ft, 354.3 ft. Extension of Superlift mast from 118.1 ft to 129.6 or 137.8 ft.
Flex frame	Infinite positioning of Superlift counterweight from 42.7 ft – 68.9 ft.
Split tray	Superlift tray frame with removable platform underneath the center stack of counterweights (center stack max. 275,600 lb).
Standard SL	118.1 ft Superlift mast incl. hoist W2. SL pendant bars, mast back stop cylinders, SL tray. Superlift counterweight 0 lb at radius 29.5 ft or 0 lb – 716,600 lb on counterweight tray at fixed radii 36.1 ft, 42.7 ft, 49.2 ft, 55.8 ft and 62.3 ft.
Variable SL	Variable 118.1 ft Superlift mast (see Standard SL). Additional vertical hydraulic cylinders and stabilisation winch on superstructure (prevents weaving of counterweight especially when traveling and slewing). Height compensation using the cylinders, lifting across obstacles possible to a certain extent. Superlift counterweight 0 lb at radius 29.5 ft or 0 lb – 716,600 lb on counterweight tray, indefinitely variable from 36.1 ft – 62.3 ft.
SL counterweight carrier	Superlift mast (see Standard SL). Telescopic frame and counterweight carrier for total weight of 716,600 lb, with 4 wheels / 2 axles (driven and steered – full manoeuvrability for slewing, trailing, and parallel modes). Superlift counterweight 88,200 lb – 716,600 lb on counterweight carrier with fixed mast radius approx. 52.5 ft; infinitely adjustable from 42.6 ft – 55.8 ft or 55.8 ft – 62.3 ft resp. with telescopic frame. The counterweight carrier allows for traveling or slewing even when the Superlift counterweight does not lift off the ground (e.g. crane with loads as indicated by load chart values in brackets).
Hoist H3	Additional hoist for main boom (to operate LF or runner), line pull same as H1, length 2133 ft.
Runner	Max. lifting capacity 119,100 lb. Mounted on boom head and boom / jib top. Operation by hoist rope 3 (see variable SL).
Runner for LF standard	Max. lifting capacity 39,700 lb. Operated by rope 3.
Special LF linkage head	Without sheave set for higher lifting capacities when using LF.
9.8 ft intermediate section	For 9.8 ft intermediate lengths.

tac.sales@tadano.com
www.tadanoamericas.com

Tadano Europe Holdings GmbH

Dinglerstraße 24, 66482 Zweibrücken, Germany
Phone +49 6332 830

Tadano America Corporation

4242 West Greens Road, Houston, TX 77066
Phone: +1 (281) 869-00300 · Fax: +1 (281) 869-0040



Lifting your dreams

